



*Dynamic* LSA

# PILOT'S OPERATING HANDBOOK

Document Number: **AS-POH-01-000**

Date of Issue: **15. 05. 2017**

Aircraft Type: **WT9 Dynamic LSA**

Model: **Club**

Aircraft Serial Number:

Aircraft Registration Number:

Type Certificate Number: **EASA.A.644**

THIS HANDBOOK INCLUDES THE MATERIAL REQUIRED TO BE FURNISHED TO THE PILOT BY THE CS-LSA REGULATIONS AND ADDITIONAL INFORMATION PROVIDED BY THE HOLDER OF TC – AEROSPOOL, SPOL. S R. O.

PAGES MARKED AS "EASA APPROVED" ARE APPROVED BY EUROPEAN AVIATION SAFETY AGENCY.

THIS AIRCRAFT MUST BE OPERATED IN COMPLIANCE WITH THE INFORMATION AND LIMITATIONS STATED IN THIS MANUAL.

This page is left blank intentionally

### RECORD OF REVISIONS

Any revision of the present manual, except actual weight data, must be recorded in the following table, and in the case of approved chapters, endorsed by the responsible airworthiness authority.

The new or amended text in the revised pages will be indicated by a black vertical line in the page margin, and the revision will be shown on the bottom side of the page.

Revision	Date	Description of Revision	Approved by
Initial issue	15. 05. 2017	Initial issue.	EASA, 31. 08. 2017
1	02. 02. 2018	Change of empty aircraft weight and CG range. Delete of fuel selector type marking.	EASA, No. 10064812
2	04. 07. 2019	Added propeller KW-31 and tow plane operation as a Supplement No. 003. Added max. empty aircraft weight. Correction of emergency and normal procedures. Improvement of pictures, descriptions, order of information in tables, numbering of figures and added other useful information. Added further notes, cautions and warnings. Formal changes, correction of mistakes, expressions and grammar.	EASA, No. 10070607
3	29. 01. 2020	Added ACL/POS/NAV lights AVE-WPSTG/R 20D MOD (2) as equivalent substitution for AVE-WPSTG/R 20D MOD (1). Removed circuit breaker values. Improved stall warning system scheme. Administrative corrections.	EASA, No. 10072698
		Added ELT Kannad AF INTEGRA as equivalent substitution for ELT Kannad 406 AF-COMPACT. Added Supplement No. 011.	EASA, No. 10072699
4	12. 06. 2020	Added XPDR GTX 335 as a Supplement No. 010. Added best glide speed. New layout of switches and circuit breakers. Corrected fuel operating ranges and stall speed example data. Corrected minimum equipment for flight operations.	EASA, No. 10075449
		Added information concerning TIS.	EASA, No. 10075449
5	24. 11. 2020	Amended expressions for throttle controller setting. Improved throttle controller picture. Added Simple Throttle Controller as a Supplement No. 012.	EASA, No. 10075525
6	28. 04. 2021	Changed reference for propeller EVRA PerformanceLine 175/xxx/805.5 manual. Corrected placards and limitation for AVGAS fuel. Administrative corrections.	EASA, No. 10076975



## WT9 Dynamic LSA / Club

Pilot's Operating Handbook

AS-POH-01-000

---

This page is left blank intentionally

### LIST OF EFFECTIVE PAGES

Chapter	Page	Status	Chapter	Page	Status
<b>Title page</b>		Revision 2	EASA Approved	2-15	Initial issue
<b>Page</b>		Initial issue	EASA Approved	2-16	Initial issue
	Page A	Revision 6			
	Page B	Initial issue	<b>3</b>		
	Page C	Revision 6	EASA Approved	3-1	Initial issue
	Page D	Revision 5	EASA Approved	3-2	Initial issue
	Page E	Revision 6	EASA Approved	3-3	Revision 4
	Page F	Initial issue	EASA Approved	3-4	Revision 2
	Page G	Initial issue	EASA Approved	3-5	Revision 2
	Page H	Initial issue	EASA Approved	3-6	Revision 5
			EASA Approved	3-7	Revision 2
<b>0</b>			EASA Approved	3-8	Revision 2
	0-1	Initial issue	EASA Approved	3-9	Revision 2
	0-2	Revision 6	EASA Approved	3-10	Revision 2
	0-3	Revision 2	EASA Approved	3-11	Revision 2
	0-4	Revision 2	EASA Approved	3-12	Revision 3
	0-5	Revision 4	EASA Approved	3-13	Revision 2
	0-6	Initial issue	EASA Approved	3-14	Revision 2
			EASA Approved	3-15	Revision 2
<b>1</b>			EASA Approved	3-16	Revision 2
	1-1	Revision 2	EASA Approved	3-17	Revision 2
	1-2	Revision 2	EASA Approved	3-18	Revision 2
	1-3	Initial issue	EASA Approved	3-19	Revision 2
	1-4	Initial issue	EASA Approved	3-20	Revision 2
	1-5	Revision 2	EASA Approved	3-21	Revision 2
	1-6	Revision 2	EASA Approved	3-22	Revision 2
	1-7	Revision 4	EASA Approved	3-23	Revision 2
	1-8	Initial issue	EASA Approved	3-24	Revision 2
			EASA Approved	3-25	Revision 2
<b>2</b>			EASA Approved	3-26	Initial issue
EASA Approved	2-1	Initial issue			
EASA Approved	2-2	Initial issue	<b>4</b>		
EASA Approved	2-3	Revision 2		4-1	Revision 2
EASA Approved	2-4	Initial issue		4-2	Revision 2
EASA Approved	2-5	Initial issue		4-3	Revision 2
EASA Approved	2-6	Initial issue		4-4	Initial issue
EASA Approved	2-7	Revision 2		4-5	Revision 2
EASA Approved	2-8	Initial issue		4-6	Revision 4
EASA Approved	2-9	Revision 2		4-7	Revision 2
EASA Approved	2-10	Revision 6		4-8	Revision 2
EASA Approved	2-11	Revision 2		4-9	Initial issue
EASA Approved	2-12	Initial issue		4-10	Revision 2
EASA Approved	2-13	Revision 4		4-11	Revision 5
EASA Approved	2-14	Revision 6		4-12	Initial issue

Chapter	Page	Status	Chapter	Page	Status
	4-13	Revision 2	EASA Approved	6-10	Revision 1
	4-14	Revision 2	EASA Approved	6-11	Initial issue
	4-15	Revision 2	EASA Approved	6-12	Revision 1
	4-16	Revision 2	EASA Approved	6-13	Initial issue
	4-17	Revision 2	EASA Approved	6-14	Initial issue
	4-18	Revision 2	EASA Approved	6-15	Initial issue
	4-19	Revision 2	EASA Approved	6-16	Initial issue
	4-20	Revision 2	EASA Approved	6-17	Initial issue
	4-21	Revision 2	EASA Approved	6-18	Initial issue
	4-22	Revision 2	EASA Approved	6-19	Initial issue
	4-23	Revision 2	EASA Approved	6-20	Revision 1
	4-24	Revision 2	EASA Approved	6-21	Revision 2
	4-25	Revision 2	EASA Approved	6-22	Initial issue
	4-26	Revision 2			
	4-27	Initial issue	<b>7</b>		
	4-28	Initial issue		7-1	Revision 4
				7-2	Revision 4
<b>5</b>				7-3	Revision 2
EASA Approved	5-1	Initial issue		7-4	Revision 2
EASA Approved	5-2	Revision 2		7-5	Revision 2
EASA Approved	5-3	Initial issue		7-6	Revision 2
EASA Approved	5-4	Initial issue		7-7	Revision 4
EASA Approved	5-5	Revision 2		7-8	Revision 4
EASA Approved	5-6	Revision 4		7-9	Revision 4
EASA Approved	5-7	Initial issue		7-10	Revision 4
EASA Approved	5-8	Initial issue		7-11	Revision 4
EASA Approved	5-9	Initial issue		7-12	Revision 4
EASA Approved	5-10	Revision 2		7-13	Revision 4
EASA Approved	5-11	Revision 2		7-14	Revision 4
EASA Approved	5-12	Revision 2		7-15	Revision 4
EASA Approved	5-13	Initial issue		7-16	Revision 4
EASA Approved	5-14	Initial issue		7-17	Revision 4
EASA Approved	5-15	Initial issue		7-18	Revision 4
EASA Approved	5-16	Initial issue		7-19	Revision 4
				7-20	Revision 4
<b>6</b>				7-21	Revision 4
EASA Approved	6-1	Revision 2		7-22	Revision 4
EASA Approved	6-2	Revision 3		7-23	Revision 4
EASA Approved	6-3	Initial issue		7-24	Revision 4
EASA Approved	6-4	Initial issue		7-25	Revision 5
EASA Approved	6-5	Initial issue		7-26	Revision 4
EASA Approved	6-6	Initial issue		7-27	Revision 4
EASA Approved	6-7	Initial issue		7-28	Revision 4
EASA Approved	6-8	Revision 2		7-29	Revision 4
EASA Approved	6-9	Revision 1		7-30	Revision 4

# WT9 Dynamic LSA / Club

## Pilot's Operating Handbook



AS-POH-01-000

Chapter	Page	Status	Chapter	Page	Status
	7-31	Revision 4		9-5	Revision 2
	7-32	Revision 6		9-6	Revision 2
	7-33	Revision 4			
	7-34	Revision 4			
	7-35	Revision 4			
	7-36	Revision 4			
	7-37	Revision 4			
	7-38	Revision 4			
	7-39	Revision 4			
	7-40	Revision 4			
	7-41	Revision 4			
	7-42	Revision 4			
	7-43	Revision 4			
	7-44	Revision 4			
	7-45	Revision 4			
	7-46	Revision 4			
<b>8</b>					
	8-1	Initial issue			
	8-2	Revision 2			
	8-3	Revision 2			
	8-4	Revision 2			
	8-5	Revision 2			
	8-6	Revision 2			
	8-7	Revision 2			
	8-8	Revision 2			
	8-9	Revision 2			
	8-10	Initial issue			
	8-11	Revision 6			
	8-12	Revision 2			
	8-13	Revision 2			
	8-14	Revision 2			
	8-15	Initial issue			
	8-16	Revision 2			
	8-17	Revision 6			
	8-18	Initial issue			
	8-19	Initial issue			
	8-20	Initial issue			
<b>9</b>					
	9-1	Initial issue			
	9-2	Revision 2			
	9-3	Revision 6			
	9-4	Initial issue			





This page is left blank intentionally

**TABLE OF CONTENTS**

Chapter	Chapter Name
<b>0</b>	<b>INTRODUCTION</b>
<b>1</b>	<b>GENERAL INFORMATION</b>
<b>2</b>	<b>LIMITATIONS</b>
<b>3</b>	<b>EMERGENCY PROCEDURES</b>
<b>4</b>	<b>NORMAL PROCEDURES</b>
<b>5</b>	<b>PERFORMANCE</b>
<b>6</b>	<b>WEIGHT AND BALANCE, AND EQUIPMENT LIST</b>
<b>7</b>	<b>DESCRIPTION OF AIRCRAFT AND SYSTEMS</b>
<b>8</b>	<b>HANDLING AND SERVICING</b>
<b>9</b>	<b>SUPPLEMENTS</b>

# 0 INTRODUCTION

## TABLE OF CONTENTS

<b>0.1</b>	<b>GENERAL .....</b>	<b>0-2</b>
<b>0.2</b>	<b>LIST OF STANDARDS.....</b>	<b>0-2</b>
<b>0.3</b>	<b>CONTINUED AIRWORTHINESS.....</b>	<b>0-2</b>
<b>0.4</b>	<b>AIRCRAFT MANUFACTURER CONTACT INFORMATION.....</b>	<b>0-2</b>
<b>0.5</b>	<b>DATA LOCATION AND CONTACT INFORMATION FOR RECOVERY OF CERTIFICATION DOCUMENTATION .....</b>	<b>0-2</b>
<b>0.6</b>	<b>SYMBOLS, ABBREVIATIONS AND TERMINOLOGY .....</b>	<b>0-3</b>
0.6.1	Speed.....	0-3
0.6.2	Meteorological Terms .....	0-3
0.6.3	Power Plant .....	0-4
0.6.4	Flight Performance and Flight Planning.....	0-4
0.6.5	Weight and Balance .....	0-4
0.6.6	Equipment.....	0-5
0.6.7	Miscellaneous.....	0-5
<b>0.7</b>	<b>CONVERSION FACTORS .....</b>	<b>0-6</b>
0.7.1	Length or Altitude .....	0-6
0.7.2	Speed.....	0-6
0.7.3	Pressure.....	0-6
0.7.4	Weight.....	0-6
0.7.5	Volume .....	0-6
0.7.6	Area .....	0-6

### 0.1 General

This Pilot's Operating Handbook (POH) has been prepared to provide pilots and instructors with all information needed for the safe and efficient operation of this aircraft. This manual contains supplementary data supplied by the manufacturer.

Before using the aircraft, read this handbook carefully: an in-depth knowledge of aircraft features and limitations will allow you to operate the aircraft safely.

### 0.2 List of Standards

The WT9 Dynamic LSA aircraft is certified according to EASA Certification Specification for Light Sport Aeroplanes CS-LSA, Amendment 1 dated 29<sup>th</sup> July 2013.

The noise requirements are shown according to Certification Specifications and Acceptable Means of Compliance for Aircraft Noise CS-36, Amendment 3 dated 20<sup>th</sup> January 2013.

### 0.3 Continued Airworthiness

Technical publications for continued airworthiness are released on the Aerospool website [www.aerospool.sk](http://www.aerospool.sk) and they may be downloaded free of charge.

Rotax Aircraft Engines releases technical publications on their website [www.flyrotax.com](http://www.flyrotax.com) from which they may be downloaded free of charge.

Documentation updates for avionics may be downloaded on [www.dynonavionics.com](http://www.dynonavionics.com) and [www.garmin.com](http://www.garmin.com).

It is the responsibility of the owner/operator of the aircraft to keep the aircraft and its documentation up to date and to comply with all technical publications. The owner/operator is responsible for keeping a current POH onboard every flight.

### 0.4 Aircraft Manufacturer Contact Information

Aerospool spol. s r. o.

Letisková 10

971 03 Prievidza

Slovak republic

Web: [www.aerospool.sk](http://www.aerospool.sk)

E-mail: [dynamic@aerospool.sk](mailto:dynamic@aerospool.sk)

### 0.5 Data Location and Contact Information for Recovery of Certification Documentation

European Aviation Safety Agency (EASA)

Postfach 10 12 53

50452 Koeln

Germany

Web: [www.easa.europa.eu](http://www.easa.europa.eu)

E-mail: [info@easa.europa.eu](mailto:info@easa.europa.eu)

## 0.6 Symbols, Abbreviations and Terminology

### 0.6.1 Speed

CAS	Calibrated airspeed; Indicated speed in kilometers per hour corrected for installation and instrument errors. CAS is equal to TAS in standard atmospheric conditions at MSL.
KCAS	CAS indicated in knots.
IAS	Indicated airspeed in kilometers per hour as shown on the airspeed indicator.
KIAS	IAS indicated in knots.
GS	Ground Speed. Speed of the aircraft relative to the ground.
TAS	True airspeed. Speed of the aircraft relative to the air. TAS is CAS corrected for altitude and temperature errors.
V <sub>A</sub>	Maneuvering airspeed. Maximum speed at which the aircraft is not overstressed at full deflection of control surfaces.
V <sub>FE</sub>	Maximum airspeed with flaps extended.
V <sub>LOF</sub>	Airspeed at lift off.
V <sub>NE</sub>	Airspeed which must never be exceeded in any operation.
V <sub>NO</sub>	Normal operating airspeed (cruise speed).
V <sub>RA</sub>	Maximum rough airspeed.
V <sub>S</sub>	The power-off stall airspeed with the aircraft in its standard configuration.
V <sub>SO</sub>	The power-off stall airspeed with the aircraft in landing configuration.
V <sub>X</sub>	Best angle-of-climb airspeed.
V <sub>Y</sub>	Best rate-of-climb airspeed.
V <sub>50</sub>	Airspeed at height 15 m (50 ft).

### 0.6.2 Meteorological Terms

AGL	Above Ground Level
MSL	Above Mean Sea Level
ISA	International Standard Atmosphere at which air is identified as a dry gas. The temperature at mean sea level is 15° Celsius (59° F), the air pressure at sea level is 1013.25 mbar (29.92 inHg), the temperature gradient up to the altitude at which the temperature reaches -56.5 °C (-67.9 °F) is -0.0065 °C/m (-0.0036 °F/ft) and 0 °C/m (0 °F/ft) above.
OAT	Outside air temperature.
Indicated Pressure Altitude	Altitude reading with altimeter set to 1013.25 mbar (29.92 inHg) air pressure.
Pressure Altitude	Altitude measured at standard pressure at MSL (1013.25 mbar / 29.92 inHg) using a barometric altimeter. Pressure altitude is the indicated altitude corrected for installation and instrument errors. Within this manual the instrument errors are assumed to be zero.
Aerodrome/Airport Pressure	Actual atmospheric pressure at the aerodrome/airport altitude.
Wind	The wind speeds used in the diagrams in this manual should be referred to as headwind or tailwind components of the measured wind.

### 0.6.3 Power Plant

hp Horsepower

kW Kilowatt

Takeoff Power

Maximum engine power for takeoff.

Maximum Continuous Power

Maximum permissible continuous engine output power during flight.

### 0.6.4 Flight Performance and Flight Planning

Demonstrated Crosswind Component

The maximum speed of the crosswind component at which the maneuverability of the aircraft during takeoff and landing has been demonstrated during type certification test flights.

Service Ceiling

The altitude at which the maximum rate of climb is 100 fpm / 0.5 m/s.

### 0.6.5 Weight and Balance

Reference Datum (RD)

An imaginary vertical plane from which all horizontal distances for the center of gravity calculations are measured. The Reference Datum is located 1.975 m forward direction from inner surface of the firewall, perpendicular to the longitudinal axis of the aircraft.

Station

A defined point along the longitudinal axis which is generally presented as a specific distance from the reference datum.

Lever Arm

The horizontal distance from the reference datum to the center of gravity (of a component).

Moment

The weight of a component multiplied by its lever arm.

Center of Gravity (CG)

Point of equilibrium for the aircraft weight.

CG position

Distance from the reference datum to the CG. It is determined by dividing the total moment (sum of the individual moments) by the total weight.

Center of Gravity Limits

The CG range which an aircraft with a given weight must be operated within.

MAC

Mean Aerodynamic Chord

Usable Fuel

The amount of fuel available for the flight plan calculation.

Unusable Fuel

The amount of fuel remaining in the tank, which cannot be safely used in flight.

Empty Weight

Weight of the aircraft including all operating fluids and maximum oil amount without unusable fuel.

Basic Empty Weight

Weight of the aircraft including all operating fluids and maximum oil amount with unusable fuel.

Useful Load

The difference between takeoff weight and empty weight.

Maximum Takeoff Weight

Maximum weight permissible for takeoff.

### 0.6.6 Equipment

ALT	Altitude or Altimeter
ASI	Airspeed Indicator
CDI	Course Deviation Indicator
COMM	Communication Transceiver
CRS	Course
EFIS	Electronic Flight Information System
ELT	Emergency Locator Transmitter
EMS	Engine Monitoring System
EPS	Emergency Parachute System
GPS	Global Positioning System
HDG	Heading
MFD	Multi-function Display
OEM	Original Equipment Manufacturer, company that controls the engineering and design rights for the LSA or an assembly, subassembly, accessory, or part installed in the aircraft, the consumable material, tools, fixtures, and test equipment used to service or maintain the aircraft.
PFD	Primary Flight Display
TIS	Traffic Information System
VSI	Vertical Speed Indicator

### 0.6.7 Miscellaneous

ATC	Air Traffic Control
CS-LSA	Certification Specification for Light Sport Aeroplanes
EASA	European Aviation Safety Agency
IFR	Instrument Flight Rules
PIC	Pilot in Command
POH	Pilot's Operating Handbook
VFR	Visual Flight Rules
RWY	Runway

**0.7 Conversion Factors****0.7.1 Length or Altitude**

1 [m] = 3.281 [ft]

1 [ft] = 0.305 [m]

1 [m] = 39.37 [in]

1 [in] = 0.0254 [m]

1 [km] = 0.5399 [nm]

1 [nm] = 1.852 [km]

**0.7.2 Speed**

1 [km/h] = 0.54 [knots]

1 [knots] = 1.852 [km/h]

1 [m/s] = 1.9425 [knots]

1 [knots] = 0.5148 [m/s]

1 [m/s] = 196.86 [fpm]

1 [fpm] = 0.00508 [m/s]

**0.7.3 Pressure**

1 [atm] = 1013.25 [mbar] = 101325 [Pa] = 29.92 [inHg]

1 [inHg] = 0.03342 [atm] = 33.865 [mbar] = 3386.5 [Pa]

**0.7.4 Weight**

1 [kg] = 2.205 [lb]

1 [lb] = 0.454 [kg]

**0.7.5 Volume**

1 [liter] = 0.2642 [U. S. gallon]

1 [U. S. gallon] = 3.785 [liter]

**0.7.6 Area**

1 [m<sup>2</sup>] = 10.76 [ft<sup>2</sup>]

1 [ft<sup>2</sup>] = 0.0929 [m<sup>2</sup>]



# 1 GENERAL INFORMATION

## TABLE OF CONTENTS

<b>1.1</b>	<b>GENERAL .....</b>	<b>1-2</b>
<b>1.2</b>	<b>INTRODUCTION TO THE POH.....</b>	<b>1-2</b>
1.2.1	Warnings, Cautions and Notes.....	1-2
1.2.2	Procedures .....	1-2
<b>1.3</b>	<b>INTRODUCTION TO THE AIRCRAFT .....</b>	<b>1-3</b>
1.3.1	Dimensions.....	1-3
1.3.2	Engine.....	1-3
1.3.3	Propeller.....	1-3
1.3.4	Three View Drawing.....	1-4
1.3.5	Ground Turning Clearance .....	1-5
<b>1.4</b>	<b>SUMMARY OF PERFORMANCE .....</b>	<b>1-6</b>
1.4.1	Weights .....	1-6
1.4.2	Top and Cruise Speeds .....	1-6
1.4.2.1	Top Speeds at Sea Level .....	1-6
1.4.2.2	Cruise Speeds at Altitudes and Power Setting.....	1-6
1.4.3	Fuel Operating Ranges .....	1-7
1.4.4	Rate of Climb.....	1-7
1.4.5	Stall Speeds .....	1-7
1.4.6	Approved Fuel Types and Fuel Capacity .....	1-8
1.4.7	Maximum Engine Power Output.....	1-8
1.4.8	Specific Loadings .....	1-8

### 1.1 General

This chapter contains information of general interest to pilots and owners. You will find useful information to familiarize yourself with the aircraft, such as dimensions, ground turning clearance, loading, fueling and summary of performance.

### 1.2 Introduction to the POH

#### 1.2.1 Warnings, Cautions and Notes

The following highlighting styles are used in this handbook to focus attention on particular information that is important.

**WARNING**

Warnings are used to call attention to operating procedures that if not strictly observed, may result in personal injury or loss of life!

**CAUTION**

Cautions are used to call attention to operating procedures that if not strictly observed, may result in damage of equipment!

**NOTE**

Notes are used to call attention to any special item, not directly related to safety, but which is important or unusual.

#### 1.2.2 Procedures

The procedures, listed in this POH are formed into tables with three columns as shown in the example below:

Column A	Column B	Column C
a.	Item 1	<b>OFF</b>
b.	<b>ITEM 2</b>	As required
c.	<b>ITEM 3</b> handle	OPEN, carefully

Column A contains letters in the alphabetical order, defining the order of the actions in the procedure.

Plain text in Column B defines the item, which is not marked by a placard in the cabin, but is generally identifiable; or supplements the other text.

Bold capital text in column B defines the item, which is marked by a placard with the identical expression in the cabin.

Plain text in Column C defines the setting or action which is generally understandable; or supplements the other text.

Capital text in Column C defines the setting or action, which usually changes the state of the item from one setting to another; and/or emphasizes the importance of the setting or action.

Bold capital text in Column C defines the setting or action, which is marked by identical expression in the cabin (by a placard or directly on the equipment.)

### 1.3 Introduction to the Aircraft

#### 1.3.1 Dimensions

Wing area	10.500 m <sup>2</sup>	112.98 ft <sup>2</sup>
Wing span	8.926 m	29.28 ft
Overall length	6.460 m	21.19 ft
Maximum height	1.850 m	6.07 ft
Wheel base	1.400 m	4.59 ft
Main landing gear track	2.240 m	7.35 ft
Maximum propeller diameter	1.750 m	68.90 in
Mean aerodynamic chord (MAC)	1.172 m	3.84 ft

#### 1.3.2 Engine

Number of engines	1
Number of cylinders	4
Engine manufacturer	BRP-Rotax GmbH & Co KG
Engine model number	Rotax 912 ULS2
Engine type	Horizontally opposed, geared, normally aspirated, spark ignition
Cooling	Combined liquid and air
Maximum takeoff power at 5800 rpm (max. 5 min.)	73.5 kW / 100 hp
Maximum continuous power at 5500 rpm	69.0 kW / 92.5 hp

#### 1.3.3 Propeller

Number of propellers	1
Propeller manufacturer	PRODUCTION EVRA, Creil, France
Propeller model number	EVRA PerformanceLine 175/xxx/805.5
Number of blades	3
Propeller diameter	1.750 m (68.90 in)
Propeller type	Fixed pitch, ground adjustable
Pitch setting (measured 270 mm from blade tip)	23°

**1.3.4 Three View Drawing**

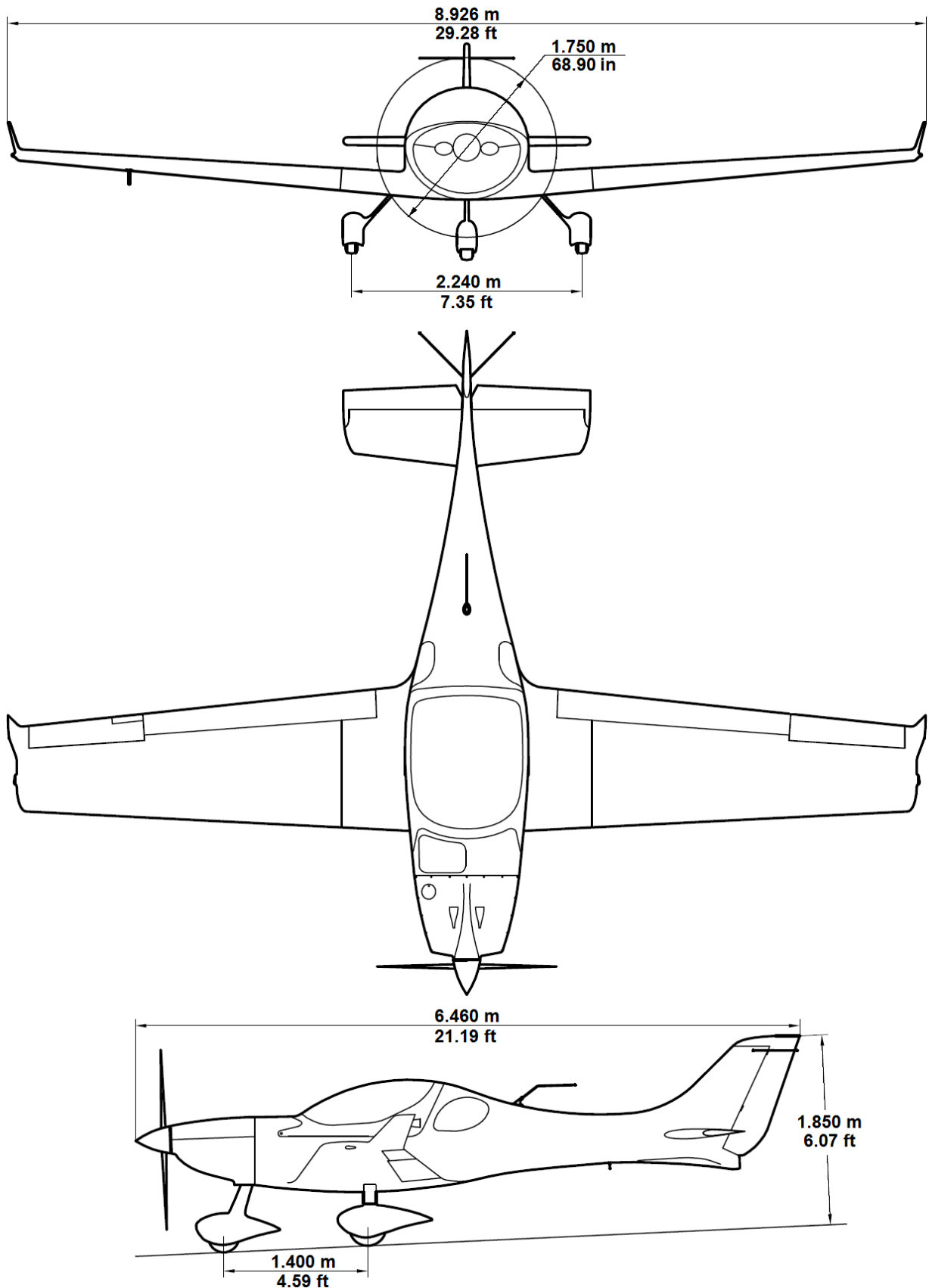

Fig. 1-1 Three view drawing

1.3.5 Ground Turning Clearance

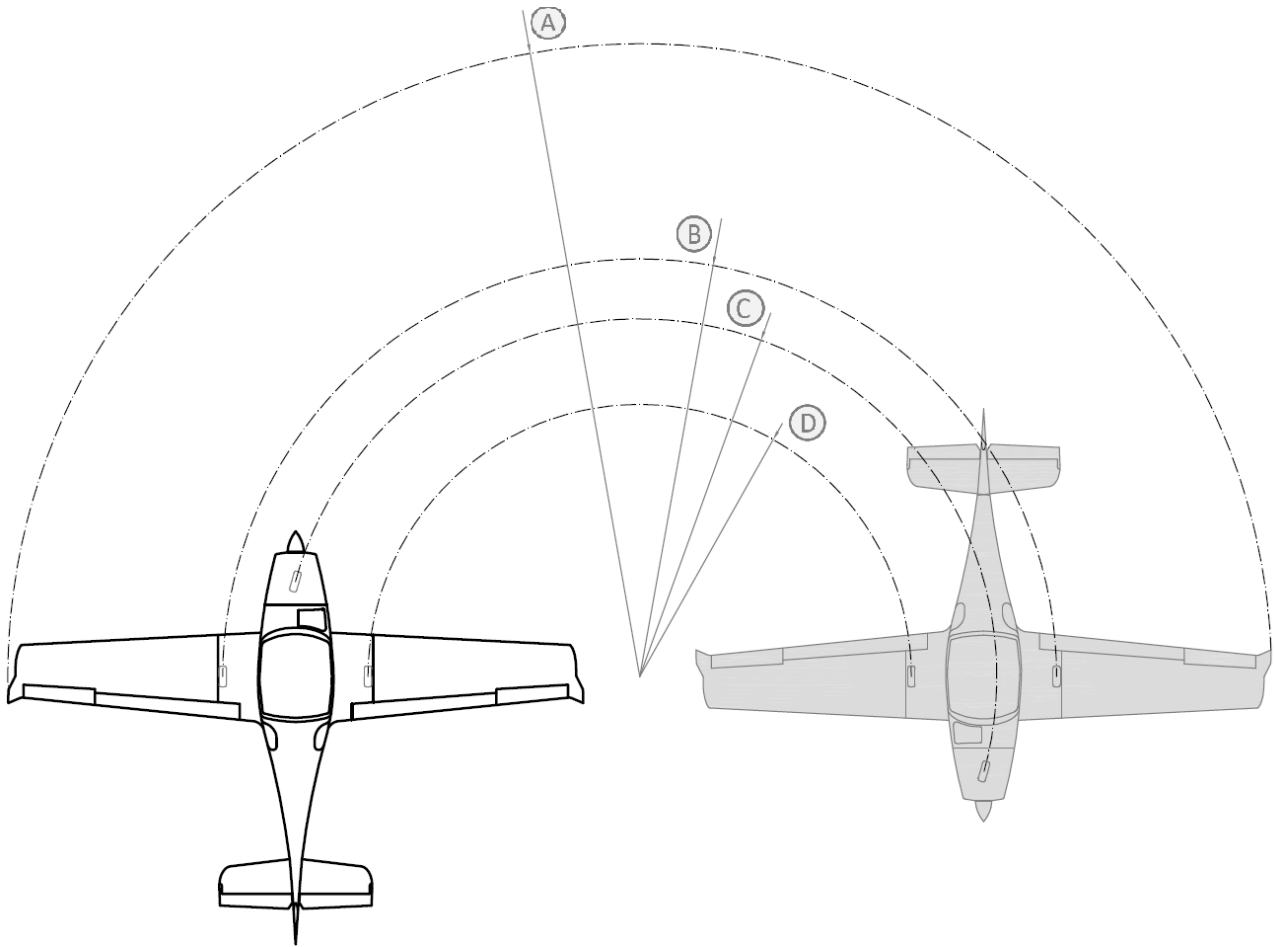

Fig. 1-2 Ground turning clearance

A	Wing tip radius	9.850 m	32.32 ft
B	Outside main gear radius	6.500 m	21.32 ft
C	Nose gear radius	5.380 m	17.65 ft
D	Inside main gear radius	4.260 m	13.98 ft

**CAUTION**

The data are valid for dry paved surface, fully turned nose gear and minimum taxi speed! Expect greater turning radius on unpaved, wet and/or slippery surfaces!

### 1.4 Summary of Performance

**NOTE**  
All airspeeds shown in the POH are IAS / KIAS, unless not stated otherwise.

#### 1.4.1 Weights

Maximum takeoff weight	600.0 kg	1323 lb
Maximum landing weight	600.0 kg	1323 lb
Empty weight	Max. 410.8 kg	Max. 906 lb
Maximum load per seat	120.0 kg	265 lb
Maximum total front baggage weight	2 x 10.0 kg	2 x 22 lb
Maximum total rear baggage weight	2 x 20.0 kg	2 x 44 lb

#### 1.4.2 Top and Cruise Speeds

##### 1.4.2.1 Top Speeds at Sea Level

		IAS	KIAS
Top speeds at sea level	At 5800 rpm	240	130
	At 5500 rpm	230	124

##### 1.4.2.2 Cruise Speeds at Altitudes and Power Setting

Pressure altitude	Engine speed	MAP	Cruise speeds	
			IAS	KIAS
ft	rpm	inHg		
2000	5 500	24.2	223	120
4000	5 500	24.4	216	117
6000	5 500	22.6	211	114
8000	5 500	21.4	201	109
10000	5 500	19.9	192	104

**NOTE**  
For more details see Chapter 5.6.

### 1.4.3 Fuel Operating Ranges

Endurances and ranges at altitude 2000 ft ISA							
Engine speed	rpm	4 300	4 500	4 800	5 000	5 500	
Fuel consumption	l/h	14.5	15.5	17.2	18.5	21.3	
IAS	km/h	165	175	190	200	223	
KIAS	knots	89	95	103	108	120	
CAS	km/h	163	172	185	194	215	
KCAS	knots	88	93	100	105	116	
TAS	km/h	172	183	196	206	228	
KTAS	knots	93	99	106	111	123	
Usable fuel (l)	119	hh:mm	8:12	7:40	6:55	6:25	5:35
		km	1412	1405	1356	1325	1274
		nm	762	759	732	715	688
	100	hh:mm	6:53	6:27	5:48	5:24	4:41
		km	1186	1181	1140	1114	1070
		mn	641	637	615	601	578
	80	hh:mm	5:31	5:09	4:39	4:19	3:45
		km	949	945	912	891	856
		nm	512	510	492	481	462
	60	hh:mm	4:08	3:52	3:29	3:14	2:49
		km	712	708	684	668	642
		nm	384	382	369	361	347
	40	hh:mm	2:45	2:34	2:19	2:09	1:52
		km	474	472	456	445	428
		nm	256	255	246	240	231
	20	hh:mm	1:22	1:17	1:09	1:04	0:56
		km	237	236	228	223	214
		nm	128	127	123	120	116

### 1.4.4 Rate of Climb

	IAS	KIAS
Best angle of climb airspeed $V_x$ (at SL)	100 IAS	54 KIAS
Rate of climb at $V_x$ (at SL)	985 fpm	
Best rate of climb airspeed $V_y$ (at SL)	127 IAS	69 KIAS
Rate of climb at $V_y$ (at SL)	1085 fpm	

### 1.4.5 Stall Speeds

	IAS	KIAS
Cruise, <b>FLAPS 0</b> (0°)	78	42
Takeoff, <b>FLAPS 1</b> (15°)	68	37
Landing – normal, <b>FLAPS 2</b> (24°)	64	35
Landing – emergency, <b>FLAPS 3</b> (35°)	61	33

### 1.4.6 Approved Fuel Types and Fuel Capacity

Approved types of fuel (Min. RON 95)	EN 228 Super	
	EN 228 Super Plus	
	AVGAS 100 LL	
Total capacity of fuel tanks	126.0 l	33.29 U. S. gal
	90.7 kg	200 lb
Total usable fuel	119.0 l	31.44 U. S. gal
	85.7 kg	189 lb
Total unusable fuel	7.0 l	1.85 U. S. gal
	5.0 kg	11 lb

### 1.4.7 Maximum Engine Power Output

Maximum takeoff power at 5800 rpm (max. 5 min.)	73.5 kW	100.0 hp
Maximum continuous power at 5500 rpm	69.0 kW	92.5 hp

### 1.4.8 Specific Loadings

Wing loading	57.14 kg/m <sup>2</sup>	11.71 lb/ft <sup>2</sup>
Power loading	8.16 kg/kW	18.00 lb/kW
	6.00 kg/hp	13.23 lb/hp



# 2 LIMITATIONS

## TABLE OF CONTENTS

<b>2.1</b>	<b>GENERAL .....</b>	<b>2-3</b>
<b>2.2</b>	<b>AIRSPEED LIMITATIONS .....</b>	<b>2-3</b>
2.2.1	Airspeed Indicator Marking.....	2-3
2.2.2	Stalling Speeds at Maximum Takeoff Weight ( $V_S$ and $V_{S0}$ ) .....	2-3
2.2.3	Flap Extended Speed Range ( $V_{S0} - V_{FE}$ ) .....	2-3
2.2.4	Operating Maneuvering Speed ( $V_O$ ).....	2-4
2.2.5	Never Exceed Speed ( $V_{NE}$ ) .....	2-4
2.2.6	Rough Air Speed ( $V_{RA}$ ) .....	2-4
<b>2.3</b>	<b>POWER PLANT LIMITATIONS.....</b>	<b>2-5</b>
2.3.1	Engine Limitations .....	2-5
2.3.2	Power Plant Instrument Markings .....	2-6
2.3.3	Taxi Power .....	2-6
<b>2.4</b>	<b>WEIGHT LIMITS.....</b>	<b>2-7</b>
<b>2.5</b>	<b>CENTER OF GRAVITY LIMITS .....</b>	<b>2-7</b>
<b>2.6</b>	<b>APPROVED MANEUVERS.....</b>	<b>2-8</b>
<b>2.7</b>	<b>FLIGHT LOAD FACTOR LIMITS .....</b>	<b>2-8</b>
<b>2.8</b>	<b>FLIGHT CREW LIMITATIONS.....</b>	<b>2-8</b>
<b>2.9</b>	<b>FLUIDS.....</b>	<b>2-9</b>
2.9.1	Fuel.....	2-9
2.9.2	Oil .....	2-10
2.9.3	Coolant .....	2-10
<b>2.10</b>	<b>ENVIRONMENTAL LIMITATIONS.....</b>	<b>2-11</b>
<b>2.11</b>	<b>KIND OF OPERATION.....</b>	<b>2-11</b>
<b>2.12</b>	<b>SERVICE CEILING .....</b>	<b>2-11</b>
<b>2.13</b>	<b>SYSTEMS AND EQUIPMENT LIMITATIONS.....</b>	<b>2-12</b>
2.13.1	Flap Limitations .....	2-12
2.13.2	Emergency Parachute System.....	2-12
2.13.3	Minimum Equipment for Flight Operation .....	2-13

<b>2.14</b>	<b>OTHER LIMITATIONS.....</b>	<b>2-13</b>
2.14.1	Smoking.....	2-13
2.14.2	Dynon SkyView System Limitations .....	2-13
2.14.3	External Power Source and Battery .....	2-13
<b>2.15</b>	<b>PLACARDS .....</b>	<b>2-14</b>
2.15.1	Interior Placards .....	2-14
2.15.2	Exterior Placards .....	2-15

## 2.1 General

The limitations included in this section are approved by the European Aviation Safety Agency.

Chapter 2 includes operating limitations, instrument markings, and basic placards necessary for safe operation of the aircraft, its standard systems and equipment.



## 2.2 Airspeed Limitations

### 2.2.1 Airspeed Indicator Marking

Color code	Significance	Airspeed or airspeed range	
White arc	Operating range with extended flaps. Lower limit is maximum weight stalling speed in landing configuration $V_{S0}$ . Upper limit is maximum speed permissible with flaps extended $V_{FE}$ .	61 – 140 IAS	33 – 76 KIAS
Green arc	Normal operating range. Lower limit is maximum weight stalling speed with flaps retracted $V_S$ . Upper limit is maximum cruising speed $V_{NO}$ .	78 – 218 IAS	42 – 118 KIAS
Yellow arc	Maneuvers must be conducted with caution and only in smooth air. (Lower limit is $V_{NO}$ . Upper limit is $V_{NE}$ )	218 – 275 IAS	118 – 148 KIAS
Red line	Maximum speed for all operations $V_{NE}$	275 IAS	148 KIAS

### 2.2.2 Stalling Speeds at Maximum Takeoff Weight ( $V_S$ and $V_{S0}$ )

Configuration	Flaps positions	Airspeed	
Cruise	FLAPS 0 (0°)	78 IAS	42 KIAS
Takeoff	FLAPS 1 (15°)	68 IAS	37 KIAS
Landing – Normal	FLAPS 2 (24°)	64 IAS	35 KIAS
Landing – Emergency	FLAPS 3 (35°)	61 IAS	33 KIAS

### 2.2.3 Flap Extended Speed Range ( $V_{S0}$ – $V_{FE}$ )

$V_{S0}$ - $V_{FE}$	Speed range from stalling airspeed (flaps fully extended) to maximum airspeed with flaps extended	61 – 140 IAS	33 – 76 KIAS
---------------------	---	--------------	--------------

### 2.2.4 Operating Maneuvering Speed ( $V_o$ )

$V_o$ at maximum takeoff weight	Do not make full or abrupt control movements above this airspeed, because under certain conditions the aircraft may be overstressed by full control deflections.	180 IAS	97 KIAS
$V_o$ at minimum flying weight		140 IAS	76 KIAS

### 2.2.5 Never Exceed Speed ( $V_{NE}$ )

$V_{NE}$	Do not exceed this airspeed in any operation.	275 IAS	148 KIAS
----------	---	---------	----------

### 2.2.6 Rough Air Speed ( $V_{RA}$ )

$V_{RA}$	Do not exceed this airspeed except in smooth air and then only with caution. Air movements in lee-wave rotors, thunderclouds, visible whirlwind, or over mountain crests are to be understood as rough air.	218 IAS	118 KIAS
----------	---	---------	----------

## 2.3 Power Plant Limitations

### 2.3.1 Engine Limitations

Engine manufacturer		BRP-Powertrain GmbH&Co.KG
Engine model number		Rotax 912 ULS2
Engine power	Max. takeoff	73.5 kW / 100.0 hp at 5800 rpm (max. 5 min.)
	Max. continuous	69.0 kW / 92.5 hp at 5500 rpm
Engine speed	Takeoff	5800 rpm (max. 5 min.)
	Continuous	5500 rpm
	Idle	1400 rpm (minimum)
Manifold pressure	Maximum	29.5 inHg
Coolant temperature	Maximum	120 °C
Oil temperature	Minimum	50 °C
	Maximum	130 °C
Oil pressure	Minimum	0.8 bar
	Maximum	7.0 bar
Exhaust gas temperature	Maximum	880 °C
Fuel pressure	Minimum	0.15 bar
	Maximum	0.50 bar
Engine start operating temperature	Minimum	-25 °C
	Maximum	50 °C
Engine zero/negative load condition	Maximum	-0.5 g (max. 5 seconds)

#### NOTE

For complete performance data and limitations see OPERATORS MANUAL FOR ROTAX ENGINE TYPE 912 SERIES, Doc. No. OM-912, latest edition.

### 2.3.2 Power Plant Instrument Markings

Digital power plant instrument SkyView SV D1000 for monitoring of engine parameters complemented with analogue engine speed indicator and fuel pressure are marked with following color code significance:

Dynon SkyView SV-D1000	Unit	Red Line Minimum Limit	Green Arc Normal Operating	Yellow Arc Caution Range	Red Line Maximum Limit
Engine speed	rpm	–	1400 – 5500	0 – 1400 5500 – 5800	5800
Manifold pressure	inHg	–	0.0 – 28.0	28.0 – 29.5	29.5
Coolant temperature	°C	–	50 – 120	–	120
Oil temperature	°C	50	90 – 110	50 – 90 110 – 130	130
Oil pressure	bar	0.8	2.0 – 5.0	0.8 – 2.0 5.0 – 7.0	7.0
Exhaust gas temperature	°C	–	200 – 880	–	880
Fuel pressure	bar	0.15	0.15 – 0.50	–	0.50
Fuel flow meter	l/h	–	0.0 – 30.0	–	over 30.0
Fuel level	l	0 – 16	16 – 45 45+	–	–

#### CAUTION

Illumination of the fuel reserve warning lamp signals that in the appropriate tank is 16 liters / 4.23 U. S. gal of fuel remaining, of which 3.5 liters / 0.92 U. S. gal is unusable fuel! This fuel is sufficient for half-hour flight at maximum continuous power!

### 2.3.3 Taxi Power

Use the minimum power settings for taxiing.

Power settings for taxiing on flat, smooth, hard surfaces is idle (min. 1400 rpm). Power settings for grassy, inclined, soft surfaces or when start motion is slightly above idle (1400 rpm).

### 2.4 Weight Limits

Maximum takeoff weight	600.0 kg	1323 lb
Maximum landing weight	600.0 kg	1323 lb
Minimum flying weight	405.0 kg	893 lb
Maximum load per seat	120.0 kg	265 lb
Maximum total front baggage weight	2x 10.0 kg	2x 22 lb
Maximum total rear baggage weight	2x 20.0 kg	2x 44 lb

**WARNING**  
Do not exceed maximum takeoff weight 600.0 kg!

**NOTE**  
Actual aircraft empty weight is mentioned in Chapter 6.

### 2.5 Center of Gravity Limits

	Metric Units	U. S. Standard Units
Reference Datum	1.975 m forward from inner surface of the firewall	77.76 in forward from inner surface of the firewall
Forward CG	2.704 m (18.3 %MAC) at 542.5 kg with straight line taper to 2.748 m (22.0 %MAC) at 600.0 kg	106.48 in (18.3 %MAC) at 1196 lb with straight line taper to 108.18 in (22.0 %MAC) at 1323 lb
Rearward CG	2.824 m (28.5 %MAC)	111.18 in (28.5 %MAC)

Center of gravity limits charts are shown at Fig. 6-2 (Metric Units) and Fig. 6-3 (U. S. Standard Units).

Rearward center of gravity limit is obtained at maximum crew weight and minimum fuel amount. Forward center of gravity limit is obtained at minimum pilot weight and maximum fuel amount. For more details see the Chapter 6.

**WARNING**

A flight shall not be commenced until the pilot-in-command is satisfied that the mass of the aircraft and CG location are within the allowed limits for takeoff and landing!

Fuel consumption moves the CG rearwards, therefore the CG location must be calculated for empty tanks as well!

The mass of the baggage must be taken into account for every CG calculation!

### 2.6 Approved Maneuvers

Aerobatic maneuvers, including spins are prohibited.

The aircraft is not approved for pitch attitudes greater than 30°.

The aircraft is not designed for aerobatic operations. Only those operations incidental to normal flight are approved.

These operations include normal stalls (except whip stalls), chandelles, lazy eights and turns in which the bank angle does not exceeding 60°.

**WARNING**  
Aerobatic maneuvers and intentional spins are prohibited!

### 2.7 Flight Load Factor Limits

Flaps	Load Factor
Flaps retracted: <b>FLAPS 0</b> (0°)	+4 / -2*
Flaps extended: <b>FLAPS 1</b> (15°), <b>FLAPS 2</b> (24°), <b>FLAPS 3</b> (35°)	+2 / 0

\*Rotax 912 ULS2 limit is -0.5 for no more than 5 seconds.

**WARNING**  
Exceeding of the maximum allowed load factor may result in overstressing of the aircraft!  
Simultaneous full deflection of control surfaces around more than one axis may result in overstressing of the aircraft, even at speeds below  $V_A$ !

### 2.8 Flight Crew Limitations

Minimum flight crew	1 pilot
Pilot in command (PIC)	Left seat only



## 2.9 Fluids

### 2.9.1 Fuel

The electric fuel pump must be ON for takeoff and landing.

Approved types of fuel (min. RON 95)	EN 228 Super	
	EN 228 Super Plus	
	AVGAS 100 LL	
Total capacity of fuel tanks	126.0 l	33.29 U. S. gal
	90.7 kg	200 lb
Total usable fuel	119.0 l	31.44 U. S. gal
	85.7 kg	189 lb
Total unusable fuel	7.0 l	1.85 U. S. gal
	5.0 kg	11 lb

### WARNING

Fueling must be done with respect to the allowed CG range and MTOW, see Chapter 6!  
Use of unapproved fuel may result in damage of engine and fuel system and eventually can lead to the engine failure!

### WARNING

The electric fuel pump must be ON for takeoff and landing!

### NOTE

Use of AVGAS 100 LL is not recommended, as it increases the engine wear. Use AVGAS 100 LL only when no other approved type of fuel is available.

For complete fuel specifications see OPERATORS MANUAL FOR ROTAX ENGINE TYPE 912 SERIES, Doc. No. OM-912 and Rotax Service Instructions SI-912-016, latest edition.

### 2.9.2 Oil

Oil capacity is 3.0 – 3.5 l (oil system + oil tank).

#### CAUTION

Use only suitable oil according to the specification stated in the placard in the engine compartment!

#### NOTE

For complete oil specifications see OPERATORS MANUAL FOR ROTAX ENGINE TYPE 912 SERIES, Doc. No. OM-912 and Rotax Service Instructions SI-912-016, latest edition.

### 2.9.3 Coolant

Coolant capacity is approximately 2.5 l (cooling system + overflow bottle).

#### CAUTION

Use only suitable coolant according to the specification stated on placard in the engine compartment! Never mix different types of coolants!

#### NOTE

For complete coolant specifications see OPERATORS MANUAL FOR ROTAX ENGINE TYPE 912 SERIES, Doc. No. OM-912 and Rotax Service Instructions SI-912-016, latest edition.

### 2.10 Environmental Limitations

Before starting preheat the engine and oil if outside temperature falls below +5 °C.

Do not operate the aircraft below outside temperature -25 °C and above +50 °C.

Flights in icing conditions are not allowed.

#### WARNING

Flights in icing conditions are prohibited!

#### NOTE

Cabin heating may be insufficient, when the outside temperature is below zero and the engine loading is low.

### 2.11 Kind of Operation

WT9 Dynamic LSA is equipped and approved for VFR day operations only.

VFR night, IFR day and IFR night operation is prohibited.

#### WARNING

VFR night and IFR operations are prohibited!

### 2.12 Service Ceiling

Service ceiling is 15 000 ft.

### 2.13 Systems and Equipment Limitations

#### 2.13.1 Flap Limitations

Normal takeoff	<b>FLAPS 1</b>
Normal landing	<b>FLAPS 2</b>
Emergency landing	<b>FLAPS 3</b>

#### 2.13.2 Emergency Parachute System

The emergency parachute system must be operative.

Maximum airspeed	290 CAS	157 KCAS
	303 IAS	164 KIAS
Minimum height above terrain	660 ft (200 m)	

#### **WARNING**

The emergency parachute system must be operative, otherwise the aircraft is not airworthy!

#### **WARNING**

Minimum recommended height for EPS activation is 660 ft (200 m) AGL and maximum airspeed is 303 IAS / 164 KIAS!  
Activation of EPS in a height less than 660 ft (200 m) may alleviate the consequences of an accident!

### 2.13.3 Minimum Equipment for Flight Operation

- a. Dynon SkyView SV-D1000 with following indications:
  - a.1 Airspeed (or standby instrument)
  - a.2 Altitude (or standby instrument)
  - a.3 Magnetic compass (or standby instrument)
  - a.4 Engine RPM (or standby instrument)
  - a.5 Fuel pressure (or standby instrument)
  - a.6 Manifold pressure
  - a.7 Oil pressure
  - a.8 Oil temperature
  - a.9 Coolant temperature
  - a.10 EGT temperature
  - a.11 Airbox temperature
  - a.12 Fuel quantity
- b. Radio
- c. Transponder (as applicable per airspace conditions)
- d. Stall Warning System (stick shaker, buzzer, warning lamp)
- e. Safety harness for each occupied seat.
- f. Operative emergency parachute system.

#### WARNING

A flight shall not be commenced if the minimum equipment for flight operation is not serviceable!

#### CAUTION

Failure of any indication not listed in the minimum equipment for flight operation should be inspected and repaired as soon as practical. Continuous operation of the aircraft with indications available only from standby instruments is not recommended!

### 2.14 Other Limitations

#### 2.14.1 Smoking

Smoking on board is prohibited!

#### 2.14.2 Dynon SkyView System Limitations

- a. For valid version of firmware of Dynon SkyView system, see Chapter 9, Supplement No. 001.
- b. Using of the Synthetic Vision information for primary terrain and obstacle avoidance is prohibited. The terrain map is intended only to enhance the situational awareness. It is the pilot's responsibility to provide terrain clearance at all time.
- c. Use of the MAP screen for pilotage navigation is prohibited. The navigation map is intended only to enhance the situational awareness.
- d. Use of TIS indication as a primary source of traffic information is prohibited. The TIS indication is intended only to enhance the traffic awareness.

#### 2.14.3 External Power Source and Battery

Max. power source output connected to the external power socket for engine starting is limited to 12 V / 90 A DC!  
Do not use external power to start the engine with a "dead" battery.

### 2.15 Placards

#### NOTE

If any placard is found missing or unreadable it should be replaced.  
 List of all placards is given in the Aircraft Maintenance Manual  
 AS-AMM-01-000, Chapter 11.

#### 2.15.1 Interior Placards

- a. Placards on the left part of instrument panel.

Airspeeds placard depends on installed equipment, see Chapter 9, Supplement No. 001.

- b. Placard on the left side of cabin.

<b>WARNING</b> IFR flights and flights in icing conditions are prohibited!	<b>WARNING</b> Aerobatic manoeuvres and intentional spins are prohibited!
APPROVED FOR: DAY - VFR	<b>WARNING</b> Do not exceed maximum take-off weight: 600 kg / 1323 lb
NO SMOKING	

- c. Placards on the LH / RH side of the baggage compartment bulkhead.

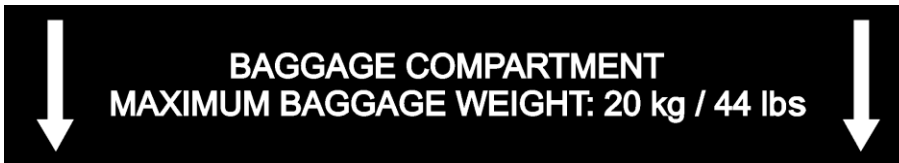

- d. Placards on the LH / RH side of the center tunnel in front of main spar.

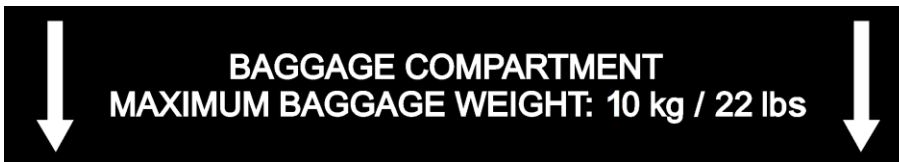

- e. Placards on the LH / RH side of the center tunnel in front of main spar and LH / RH side of the baggage compartment bulkhead.

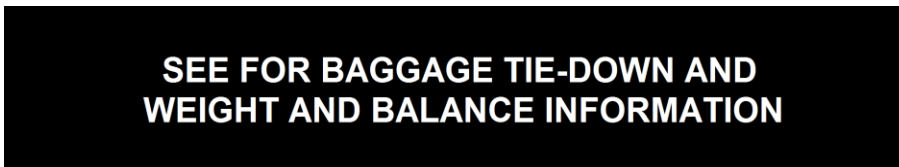

- f. Placards on the LH / RH side the baggage compartment on the cover of torsion tube. Placards on the LH / RH side the baggage compartment on the cover of fuel filters.



### 2.15.2 Exterior Placards

- a. Placards on the wing center section, wing flaps.

**NO STEP**

- b. Placards on the wings, near fuel tank caps.

FUEL CAPACITY:  
MAX. 63.0 l / 16.64 U. S. gal  
  
MOGAS RON 95 / AKI 91  
AVGAS 100 LL

- c. Placard on the upper engine cowling near door for oil level check.

MAX 3.0 l / 0.79 U. S. gal  
  
AEROSHELL SPORT PLUS 4  
API SL / SAE-10W-40

- d. Placards on the outer part of the main landing gear legs.

**250 kPa**

- e. Placard on the left part of the nose landing gear leg.

**200 kPa**

- f. Placards on the trailing edge of the control surfaces.

**NO PUSH**

- g. Placards near jack points on the fuselage / wing center section bottom part.

**LIFT HERE**

- h. Placards near drain valves on the wing bottom part.

**DRAIN HERE**

- i. Placards are located on the both sides of fuselage under the windows in baggage compartment.



**This aircraft is equipped with  
a ballistically-deployed  
emergency parachute system**

- j. Placard is located on the emergency parachute system cover.



Rocket Deployed Parachute Egress Area

**STAY CLEAR**

Emergency information at: [www.stratos07.cz](http://www.stratos07.cz)

or call (+420) 312 658151-after hours & weekends call (+420) 603 416872

Contact U.S.A.: call (321) 9603438, [www.magnumparachutes.com](http://www.magnumparachutes.com)

Contact Germany: call (+490) 9221 879312, [www.junkers-profly.de](http://www.junkers-profly.de)



# 3 EMERGENCY PROCEDURES

## TABLE OF CONTENTS

<b>3.1</b>	<b>GENERAL .....</b>	<b>3-3</b>
<b>3.2</b>	<b>AIRSPEED FOR EMERGENCY PROCEDURES.....</b>	<b>3-3</b>
<b>3.3</b>	<b>EMERGENCY ENGINE SHUTDOWN ON GROUND .....</b>	<b>3-3</b>
<b>3.4</b>	<b>ENGINE FAILURE .....</b>	<b>3-4</b>
3.4.1	Engine Failure on Takeoff Roll.....	3-4
3.4.2	Engine Failure on Takeoff up to Height 500 ft (150 m) AGL .....	3-4
3.4.3	Engine Failure in Flight .....	3-5
3.4.4	Engine Partial Power Loss .....	3-5
<b>3.5</b>	<b>AIR START.....</b>	<b>3-6</b>
<b>3.6</b>	<b>SMOKE AND FIRE .....</b>	<b>3-7</b>
3.6.1	Engine Fire on Ground .....	3-7
3.6.2	Engine Fire on Takeoff.....	3-7
3.6.3	Engine Fire in Flight .....	3-8
3.6.4	Cabin Fire on Ground .....	3-8
3.6.5	Cabin Fire on Takeoff and in Flight .....	3-9
<b>3.7</b>	<b>EMERGENCY DESCENT .....</b>	<b>3-9</b>
<b>3.8</b>	<b>LANDING EMERGENCIES .....</b>	<b>3-10</b>
3.8.1	Precautionary Landing with Engine Power .....	3-10
3.8.2	Landing with Flat Tire .....	3-11
3.8.2.1	Main Wheel Tire .....	3-11
3.8.2.2	Nose Wheel Tire .....	3-11
3.8.3	Emergency Landing without Engine Power .....	3-12
3.8.4	Ditching .....	3-13
<b>3.9</b>	<b>SYSTEM EMERGENCIES .....</b>	<b>3-14</b>
3.9.1	Low Oil Pressure .....	3-14
3.9.2	High Oil Pressure .....	3-14
3.9.3	Low Fuel Pressure .....	3-15
3.9.4	High Coolant Temperature.....	3-15
3.9.5	Alternator Failure .....	3-16

3.9.6	Overvoltage .....	3-17
3.9.7	Elevator/Aileron Trim System Failure .....	3-17
3.9.8	Brake Failure during Taxi.....	3-17
3.9.9	Loss of Primary Instrument Dynon SkyView SV-D1000 .....	3-18
<b>3.10</b>	<b>INADVERTENT ICING ENCOUNTER.....</b>	<b>3-20</b>
<b>3.11</b>	<b>LOSS OF FLIGHT CONTROLS.....</b>	<b>3-21</b>
3.11.1	Aileron Control Failure .....	3-21
3.11.2	Elevator Control Failure .....	3-21
3.11.3	Rudder Control Failure .....	3-21
<b>3.12</b>	<b>SPINS.....</b>	<b>3-22</b>
3.12.1	Inadvertent spin .....	3-22
<b>3.13</b>	<b>OTHER EMERGENCIES .....</b>	<b>3-23</b>
3.13.1	Vibrations .....	3-23
3.13.2	Fuel Selector Failure.....	3-23
3.13.3	Unsecured Canopy .....	3-23
3.13.3.1	During Takeoff Roll.....	3-23
3.13.3.2	After Lift Off or during Climbing.....	3-24
3.13.3.3	During Level Flight.....	3-24
3.13.4	Emergency Parachute System Activation .....	3-25

### 3.1 General

While this chapter covers most emergencies and critical situations that could occur in the WT9 Dynamic LSA, it is not a substitute for a thorough knowledge of the aircraft and aviation techniques. Proper study of this chapter while on the ground will help you prepare for critical situations.

Emergencies caused by aircraft or engine malfunction are extremely rare if proper pre-flight inspection and maintenance are performed. Nevertheless, an emergency may arise. The basic instructions described in this chapter should be considered and applied as necessary to correct the problem.

When facing an emergency situation, keep in mind the following:

**Control the aircraft** – Maintain aircraft control and do not stop flying. Always proceed in this order: aviate, navigate and communicate.

**Analyze the situation** – While you maintain control of the aircraft, evaluate the situation. Check the engine parameters and determine the possible reasons.

**Perform appropriate action** – To correct the problem or allow safe recovery of the aircraft, follow the procedures in this chapter.

**Land as soon as possible** – Once you get out of the emergency situation, evaluate if it is safe to continue the flight. Land at the nearest suitable airport.

### 3.2 Airspeed for Emergency Procedures

Maneuvering speed	600 kg / 1323 lb	180 IAS	97 KIAS
Best glide speed	<b>FLAPS 0</b>	120 – 130 IAS	65 – 70 KIAS
Emergency landing speed	<b>FLAPS 3</b>	110 – 115 IAS	59 – 62 KIAS
Emergency descent speed	Smooth air max.	275 IAS	148 KIAS
	Rough air max.	218 IAS	118 KIAS

### 3.3 Emergency Engine Shutdown on Ground

a. <b>IGNITION</b>	OFF both circuits
b. <b>FUEL PUMP</b>	OFF if used
c. <b>FUEL selector</b>	<b>OFF</b>
d. Starter key	<b>OFF</b>
e. <b>MASTER SWITCH</b>	OFF
f. <b>THROTTLE</b>	IDLE

### 3.4 Engine Failure

#### 3.4.1 Engine Failure on Takeoff Roll

If the engine failure occurs during the takeoff roll, abort the takeoff and stop the aircraft.

a.	<b>THROTTLE</b>	IDLE
b.	Brake	As required
c.	<b>FUEL PUMP</b>	OFF
d.	<b>IGNITION</b>	OFF both circuits
e.	Starter key	<b>OFF</b>
f.	<b>MASTER SWITCH</b>	OFF
g.	<b>FUEL selector</b>	<b>OFF</b>
h.	All switches	OFF
i.	Brake	<b>PARK</b>

#### WARNING

While exiting the aircraft, make sure the exit path is clear of other aircraft, spinning propellers and other hazards!

#### 3.4.2 Engine Failure on Takeoff up to Height 500 ft (150 m) AGL

If the engine failure occurs during takeoff at low height, pitch the nose down to maintain airspeed. Landing should be made straight ahead, turning only to avoid obstructions.

a.	Airspeed	120 – 130 IAS / 65 – 70 KIAS
Sufficient runway:		
b.	Land	According to Chapter 3.8.3, straight ahead on runway
Insufficient runway:		
c.	Land	According to Chapter 3.8.3, only straight ahead

#### WARNING

In the case of insufficient runway, do not turn back to the runway at height below 500 ft (150 m) AGL. Perform straight ahead landing, turning only to avoid obstructions!

#### WARNING

In the case of rough terrain activate the EPS according to Chapter 3.13.4!

### 3.4.3 Engine Failure in Flight

If the engine failure occurs during flight, pitch the nose down to establish the best glide speed. Select a suitable landing area and try to identify the cause of engine failure and correct it. If altitude or terrain does not permit a safe landing, activation of the EPS may be required (see Chapter 3.13.4).

a.	Airspeed	120 – 130 IAS / 65 – 70 KIAS
b.	Emergency landing area	Select a suitable landing area, if possible, against the wind, and with no obstacle on the final approach
c.	Air start	If altitude permits, start the engine according to Chapter 3.5
Unsuccessful engine start:		
d.	Land	According to Chapter 3.8.3

**WARNING**  
In the case of rough terrain activate the EPS according to Chapter 3.13.4!

### 3.4.4 Engine Partial Power Loss

Partial power loss is indicated by fluctuating engine rpm, reduced or fluctuating manifold pressure, rough or irregular engine running. If the engine partial power loss permits a level flight, land at a suitable airfield as soon as possible.

There is a procedure to correct some conditions contributing to a partial power loss.

Insufficiency of fuel in the tank (detected through loss of fuel pressure):

a.	<b>FUEL PUMP</b>	ON
b.	<b>FUEL</b> selector	Fullest tank
c.	Engine parameters	Check

Irregular running of the engine may occur due to carburetor icing:

d.	<b>CARBUR. PREHEATING</b>	OPEN (pull to open) to restore normal power, smooth running
e.	Engine parameters	Check

Smooth running not recovered:

f.	Land	According to Chapter 3.8.3
----	------	----------------------------

**WARNING**  
If there is a strong smell of fuel in the cabin, shut down the engine and perform the emergency landing without engine power according to Chapter 3.8.3!

### 3.5 Air Start

a.	Airspeed	120 – 130 IAS / 65 – 70 KIAS
b.	Altitude	Check
c.	Field selection	Select according to available altitude
d.	<b>AVIONICS</b>	OFF
e.	<b>LAND</b> lights	Check OFF
f.	<b>NAV / ACL</b> lights	OFF
g.	<b>FUEL</b> selector	Fullest tank
h.	<b>CHOKE</b>	CLOSED
i.	<b>THROTTLE</b>	Slightly OPEN (5 mm of throttle controller travel)
j.	<b>MASTER SWITCH</b>	ON
k.	<b>FUEL PUMP</b>	ON
l.	<b>IGNITION</b>	ON both circuits
m.	Starter key	First <b>OFF</b> , hold <b>START</b> , after engine is started release to <b>CHARGE</b>
As soon as engine runs:		
n.	Engine parameters	Check
o.	<b>AVIONICS</b>	ON
p.	<b>FUEL PUMP</b>	OFF
Unsuccessful start:		
q.	Land	According to Chapter 3.8.3

#### WARNING

If fuel fumes or a fuel leak is discovered in the cabin, do not perform an air start and turn off all unnecessary equipment!

#### WARNING

If the air start is unsuccessful up to 500 ft (150 m) AGL, perform an emergency landing according to Chapter 3.8.3!

### 3.6 Smoke and Fire

#### 3.6.1 Engine Fire on Ground

a.	Brake	<b>MAX</b>
b.	<b>FUEL PUMP</b>	OFF
c.	<b>FUEL</b> selector	<b>OFF</b>
d.	<b>THROTTLE</b>	MAX
e.	<b>IGNITION</b>	OFF both circuits after the engine has stopped
f.	Starter key	<b>OFF</b>
g.	<b>MASTER SWITCH</b>	OFF
h.	Safety harness	Release
i.	Canopy	Open (if stuck, break glass with best available means)
j.	Aircraft	Exit immediately
k.	Fire	Try to extinguish with best available means

#### WARNING

While exiting the aircraft, make sure the exit path is clear of other aircraft, spinning propellers and other hazards!

#### 3.6.2 Engine Fire on Takeoff

a.	<b>FUEL PUMP</b>	OFF
b.	<b>FUEL</b> selector	<b>OFF</b>
c.	<b>THROTTLE</b>	MAX
d.	<b>CABIN HEATING / VENTILATION</b>	CLOSE
e.	Windows	CLOSE (if smoke is in the cabin OPEN)
f.	<b>IGNITION</b>	OFF both circuits after the fuel has been consumed
g.	Land	According to Chapter 3.8.3
h.	Safety harness	Release
i.	Canopy	OPEN (if stuck, break glass with best available means)
j.	Aircraft	Exit immediately
k.	Fire	Try to extinguish with best available means

### 3.6.3 Engine Fire in Flight

a.	<b>FUEL PUMP</b>	Check OFF
b.	<b>FUEL</b> selector	<b>OFF</b>
c.	<b>THROTTLE</b>	MAX
d.	<b>CABIN HEATING / VENTILATION</b>	CLOSE
e.	Windows	CLOSE (if smoke is in the cabin OPEN)
f.	<b>IGNITION</b>	OFF both circuits after the fuel has been consumed
g.	Fire	Try to extinguish with a sideslip
h.	Airspeed	Smooth air – max. 275 IAS / 148 KIAS
		Rough air – max. 218 IAS / 118 KIAS
i.	Land	According to Chapter 3.8.3
j.	Safety harness	Release
k.	Canopy	OPEN (if stuck, break glass with best available means)
l.	Aircraft	Exit immediately
m.	Fire	Try to extinguish with best available means

#### CAUTION

After the fire has been extinguished, do not start the engine again!

### 3.6.4 Cabin Fire on Ground

a.	Brake	<b>MAX</b>
b.	Fire source	Locate
c.	<b>IGNITION</b>	OFF both circuits
d.	Starter key	<b>OFF</b>
e.	<b>MASTER SWITCH</b>	OFF
f.	Safety harness	Release
g.	Canopy	OPEN (if stuck, break glass with best available means)
h.	Aircraft	Exit immediately
i.	Fire	Try to extinguish with best available means

#### WARNING

While exiting the aircraft, make sure the exit path is clear of other aircraft, spinning propellers and other hazards!



### 3.6.5 Cabin Fire on Takeoff and in Flight

Opening of cabin heating and venting may feed the fire. It may be necessary to ventilate the cabin to avoid of crew incapacitation from smoke inhalation.

a.	<b>MASTER SWITCH</b>	OFF
b.	<b>CABIN HEATING / VENTILATION</b>	CLOSE to not feed the fire
c.	Fire source	Locate
d.	Fire	Try to extinguish with best available means
e.	<b>CABIN VENTILATION and Windows</b>	Fully OPEN to ventilate the cabin
f.	Land	According to Chapter 3.8.1
g.	Safety harness	Release
h.	Canopy	OPEN (if stuck, break glass with best available means)
i.	Aircraft	Exit immediately
j.	Fire	Try to extinguish with best available means

#### WARNING

Opened heat/ventilation and windows may feed the fire. To avoid of crew incapacitation from smoke inhalation, it may be necessary to ventilate the cabin!

#### NOTE

With **MASTER SWITCH** OFF, the engine will continue to run.  
PFD and MFD will operate with its own backup battery.

### 3.7 Emergency Descent

a.	<b>THROTTLE</b>	IDLE
b.	Airspeed	Smooth air – max. 275 IAS / 148 KIAS
		Rough air – max. 218 IAS / 118 KIAS
c.	Engine speed	Do not overrun

#### CAUTION

Do not exceed  $V_{RA}$  218 IAS / 118 KIAS when descending in rough air!

### 3.8 Landing Emergencies

#### 3.8.1 Precautionary Landing with Engine Power

In the event of a major failure, disorientation, shortage of fuel, dangerous deterioration of meteorological conditions (visibility, thunderstorm) or the pilot experiencing nausea which could lead to incapacitation, a precautionary landing should be conducted.

a.	Landing area	Select, determine wind direction
b.	Radio	Transmit MAYDAY (121.5 MHz) giving position and intentions
c.	Transponder	Set 7700
d.	<b>ELT REMOTE CONTROL</b>	ACTIVATE if off airfield
e.	Field check	Check the preferred area for landing carefully to inspect the terrain properties (obstructions, surface conditions)
f.	Circle pattern	At a safe altitude as permitted by cloud base, extend "down wind" position
g.	<b>FUEL PUMP</b>	ON
h.	Wing flaps	<b>FLAPS 3</b> , extend gradually, check locked
i.	Airspeed	110 – 115 IAS / 59 – 62 KIAS
j.	<b>THROTTLE</b>	As required
k.	Visual contact	Don't lose sight of the selected field in the case of low visibility
l.	Touchdown	Immediately after passing the edge of the selected landing field; Avoid any obstacles in the final approach path
m.	Brake	Apply heavily until stopped (depending on the surface)
n.	<b>ELT REMOTE CONTROL</b>	If OK then OFF

### 3.8.2 Landing with Flat Tire

If a flat tire occurs during takeoff and you cannot abort, land as soon as conditions permit.

#### 3.8.2.1 Main Wheel Tire

a.	Safety harness	Fasten
b.	Wing flaps	<b>FLAPS 3</b> , extend gradually, check locked
c.	Airspeed	110 – 115 IAS / 59 – 62 KIAS
d.	<b>THROTTLE</b>	As required
e.	Touch-down	Land on the side of the runway corresponding to the good tire
f.	Flat tire	Relieve using aileron control
g.	Directional control	Maintain with rudder control
h.	Brake	Do not apply; Apply carefully only if insufficient runway remaining
i.	Taxiing	Do not taxi
j.	Engine	Perform normal engine shutdown
k.	Crew	Seek assistance

#### CAUTION

During landing keep the damaged wheel off the ground as long as possible using the aileron control!

#### 3.8.2.2 Nose Wheel Tire

a.	Safety harness	Fasten
b.	Wing flaps	<b>FLAPS 3</b> , extend gradually, check locked
c.	Airspeed	110 – 115 IAS / 59 – 62 KIAS
d.	<b>THROTTLE</b>	As required
e.	Nose wheel	Hold off the ground as long as possible using elevator control
f.	Brake	Do not apply; Apply carefully only if insufficient runway remaining
g.	Taxiing	Do not taxi
h.	Engine	Perform normal engine shutdown
i.	Crew	Seek assistance

#### CAUTION

During landing keep the damaged wheel off the ground as long as possible using the elevator control!

### 3.8.3 Emergency Landing without Engine Power

After establishing a glide or landing speed, perform as many of the checklist items as time permits.

a.	Airspeed	120 – 130 IAS / 65 – 70 KIAS
b.	Emergency landing area	Select a suitable landing area, if possible, against the wind, and with no obstacles on the final approach
c.	Radio	Transmit MAYDAY (121.5 MHz) giving position and intentions
d.	Transponder	Set 7700
e.	<b>ELT REMOTE CONTROL</b>	ACTIVATE if off airfield
f.	Flaps	<b>FLAPS 3</b> , extend gradually, check locked
g.	Airspeed	110 – 115 IAS / 59 – 62 KIAS
h.	<b>FUEL PUMP</b>	OFF
i.	<b>FUEL selector</b>	<b>OFF</b>
j.	<b>IGNITION</b>	OFF both circuits
k.	Starter key	<b>OFF</b>
l.	<b>MASTER SWITCH</b>	OFF shortly before landing
m.	Safety harness	Fasten
After landing:		
n.	<b>ELT REMOTE CONTROL</b>	If OK then OFF
o.	Crew	Seek assistance

#### WARNING

Along with the emergency landing, activation of EPS according to Chapter 3.13.4 should always be considered, especially if no suitable area for landing can be selected!

#### NOTE

With **MASTER SWITCH** OFF, the PFD and MFD will operate with its own backup battery.

### 3.8.4 Ditching

After establishing a descent, perform as many of the checklist items as time permits.

a.	Emergency call	Transmit MAYDAY (121.5 MHz) giving position and intentions (if time and altitude permit)
b.	Transponder	Set 7700 (if time and altitude permit)
c.	<b>ELT REMOTE CONTROL</b>	ACTIVATE (if time and altitude permit)
d.	<b>RESCUE SYSTEM</b> actuator	ACTIVATE according to Chapter 3.13.4
e.	Aircraft	Exit immediately
f.	Life vests and rafts	If available, inflate when clear of aircraft
g.	Crew	Seek assistance

### WARNING

Do not try to ditch due to the risk of capsizing the aircraft!

### 3.9 System Emergencies

#### 3.9.1 Low Oil Pressure

Low oil pressure is indicated by the red **OIL PRESS.** warning lamp coming on.

a.	Oil temperature	Check
If oil temperature is rising:		
b.	<b>THROTTLE</b>	Reduce power to minimum required for flight
c.	Land	According to Chapter 3.8.1
If oil temperature is normal:		
d.	Oil temperature	Monitor
e.	Oil pressure	Monitor
f.	Land	As soon as possible

#### CAUTION

Be prepared for engine failure and emergency landing without engine power according to Chapter 3.8.3!

#### 3.9.2 High Oil Pressure

a.	<b>THROTTLE</b>	Reduce power to minimum required for flight
b.	Oil pressure	Monitor
c.	Oil temperature	Monitor
If oil temperature / pressure is rising:		
d.	Land	According to Chapter 3.8.1
If oil pressure remains unchanged:		
e.	Land	As soon as possible

#### CAUTION

Be prepared for engine failure and emergency landing without engine power according to Chapter 3.8.3!

**3.9.3 Low Fuel Pressure**

a.	<b>FUEL PUMP</b>	ON
b.	<b>FUEL</b> selector	Fullest tank
If fuel pressure is decreasing:		
c.	Land	According to Chapter 3.8.1
If fuel pressure is normal:		
d.	Fuel pressure	Monitor
e.	Land	As soon as possible

**CAUTION**  
Be prepared for engine failure and emergency landing without engine power according to Chapter 3.8.3!

**3.9.4 High Coolant Temperature**

a.	<b>THROTTLE</b>	Reduce power to minimum required for flight
If coolant temperature is rising:		
b.	Land	According to Chapter 3.8.1
If coolant temperature is normal:		
c.	Coolant temperature	Monitor
d.	Land	As soon as possible

**CAUTION**  
Be prepared for engine failure and emergency landing without engine power according to Chapter 3.8.3!

### 3.9.5 Alternator Failure

Loss of alternator output is detected through a zero or minus values reading on the ammeter and warning lamp **CHARGE** coming on. Electrical power malfunctions are accompanied by an excessive rate of charge or a discharge rate indicated by ammeter.

a.	<b>THROTTLE</b>	Increase above 3000 rpm
b.	<b>NAV / ACL</b> lights	OFF
c.	<b>LAND</b> lights	OFF
d.	<b>FUEL PUMP</b>	OFF
e.	<b>MASTER SWITCH</b>	OFF - ON

If no increase in the ammeter reading is noted:

f.	All unnecessary electrical equipment	OFF
g.	Voltmeter	Monitor battery voltage
h.	Land	As soon as possible

#### CAUTION

All electrical loads are being supplied by the battery. Turn off all unnecessary equipment! Disconnect all external equipment from the instrument panel power outlets!  
Operating time of battery in good condition is up to 30 minutes!

#### CAUTION

Be aware, if the **AVIONICS** switch is turned OFF, the radio communication is lost!

#### NOTE

Operating time of battery depends on its condition.  
Dynon SkyView system has its own backup battery.



**3.9.6 Overvoltage**

If the trouble was caused by a momentary overvoltage condition (16.5 V and up), the following procedure should return the voltmeter to a normal reading.

a.	<b>THROTTLE</b>	Reduce power to minimum for flight
b.	<b>AVIONICS</b>	OFF
c.	<b>NAV / ACL</b> lights	OFF
d.	<b>LAND</b> lights	OFF
e.	<b>FUEL PUMP</b>	OFF
f.	<b>MASTER SWITCH</b>	OFF - ON

If the overvoltage condition (16.5 V and up) is noted:

g.	All unnecessary electrical equipment	OFF
h.	Voltmeter	Monitor battery voltage
i.	Land	As soon as possible

**CAUTION**

All electrical loads are being supplied by the battery! Turn off all unnecessary equipment! Disconnect all external equipment from the power outlets!

Operating time of battery in good condition is up to 30 minutes! Be aware, if the **AVIONICS** switch is turned OFF, the radio communication is lost!

**NOTE**

With **MASTER SWITCH** OFF, the engine will continue to run. PFD and MFD will operate with its own backup battery.

**3.9.7 Elevator/Aileron Trim System Failure**

If the failure of any trim system occurs, the control system can be overridden by use of the control stick. The forces on the control stick will increase with the deflection.

a.	Aircraft control	Maintain manually
b.	<b>THROTTLE</b>	As required
c.	Control stick	Manually hold the pressure

**3.9.8 Brake Failure during Taxi**

If the brakes fail, the aircraft is fully steerable by nose wheel.

a.	<b>THROTTLE</b>	IDLE
b.	Directional control	Direct the aircraft to a safe area
c.	Engine	Perform an emergency engine shutdown on ground according to Chapter 3.3

### 3.9.9 Loss of Primary Instrument Dynon SkyView SV-D1000

Dynon SkyView SV-D1000 annunciates important notifications on screen, in a dedicated message window and via audio output.

Dynon SkyView SV-D1000 notifies users with a large RED X and a descriptive label if a major failure occurs that prevents the display from displaying information. A RED X may overlay an entire page if a data source such as an EMS module fails or a RED X may overlay a single widget if a single engine sensor fails or is not connected.

#### RED X on PFD Page:

a.	<b>LH D1000</b> circuit breaker	Check pressed in - if open, reset (close) circuit breaker; if circuit breaker opens again, do not reset again
b.	Standby airspeed indicator	Use for airspeed information
c.	Standby altimeter	Check current barometric pressure set; use for altitude information
d.	Standby vertical speed indicator	Use for rate of climb / descent speed information
e.	Standby slip indicator	Monitor

#### RED X on MFD Page:

a.	<b>RH D1000</b> circuit breaker	Check pressed in - if open, reset (close) circuit breaker; if circuit breaker opens again, do not reset again
b.	Standby RPM indicator	Use for monitoring of the engine speed
c.	Standby fuel pressure indicator	Use for monitoring of the fuel pressure
d.	<b>OIL PRESS.</b> warning lamp	Use for monitoring of the oil pressure; illumination of warning lamp signalizes that oil pressure is low
e.	<b>LH FUEL RES. / RH FUEL RES.</b> warning lamp	Use for monitoring of the fuel low level; a red warning lamp will be illuminated when 16 liters of fuel remain in the fuel tank

**WARNING**  
If both SkyView displays fail, land at the nearest airfield!

**CAUTION**  
It is not recommended to fly intentionally with only one serviceable Dynon SkyView SV-D1000!

**PFD Frozen Screen:**

a. <b>PFD</b>	Restart PFD; if impossible, or it refreezes, do not restart again
b. <b>MFD</b>	Display the flight data

**MFD Frozen Screen:**

a. <b>MFD</b>	Restart MFD; if impossible, or it refreezes, do not restart again
b. <b>PFD</b>	Display the engine data

**Both PFD and MFD Frozen Screen:**

a. <b>PFD / MFD</b>	Restart PFD / MFD; if impossible, or it refreezes, do not restart again
b. Standby instruments	Use for information
c. <b>OIL PRESS.</b> warning lamp	Use for monitoring of the oil pressure; illumination of warning lamp signalizes that oil pressure is low
d. <b>LH FUEL RES. / RH FUEL RES.</b> warning lamp	Use for monitoring the fuel low level; red warning lamp will be illuminated when 16 liters of fuel remain in the fuel tank
e. Land	As soon as possible

**PFD Black Out:**

a. <b>LH D1000</b> circuit breaker	Check pressed in - if open, reset (close) circuit breaker; if circuit breaker opens again, do not reset again
b. <b>MFD</b>	Display flight data

**MFD Black Out:**

a. <b>RH D1000</b> circuit breaker	Check pressed in - if open, reset (close) circuit breaker; if circuit breaker opens again, do not reset again
b. <b>PFD</b>	Display engine data

**Both PFD and MFD Black Out:**

a. <b>LH/RH D1000</b> circuit breaker	Check pressed in - if open, reset (close) circuit breaker; if circuit breaker opens again, do not reset again
b. Standby instruments	Use for information
c. <b>OIL PRESS.</b> warning lamp	Use for monitoring of the oil pressure; illumination of warning lamp signalizes that oil pressure is low
d. <b>LH FUEL RES. / RH FUEL RES.</b> warning lamp	Use for monitoring the fuel low level; red warning lamp will be illuminated when 16 liters of fuel remain in the fuel tank
e. Land	As soon as possible

### 3.10 Inadvertent Icing Encounter

a.	<b>CARBUR. PREHEATING</b>	OPEN (pull to open)
b.	Icing area	Leave - turn back or change altitude to obtain an outside air temperature that is less conducive to icing
c.	<b>CABIN HEATING</b>	OPEN (pull to open)
d.	<b>THROTTLE</b>	Increase engine speed to minimize ice build-up on the propeller blades; if excessive vibration is noted, immediately reduce engine speed to idle, and then rapidly apply full throttle
e.	Manifold pressure indicator	Check - a loss of manifold pressure could be caused by ice blocking the air intake filter
f.	<b>THROTTLE</b>	As required to hold manifold pressure
g.	Control surfaces	Continue move to maintain their movability
h.	Landing planning	Plan a landing at the nearest airport; with an extremely rapid ice build-up, select a suitable off airfield landing site
i.	Wing flaps	Leave <b>FLAPS 0</b> ; with a severe ice build-up on the horizontal tail, the change in wing wake airflow direction caused by wing flap extension could result in a loss of elevator effectiveness
j.	Windshield	Open left window and, if practical, scrape ice from a portion of the windshield for visibility in the landing approach
k.	Approach	Perform approach using a forward slip, if necessary, for improved visibility
l.	Airspeed	130 to 140 IAS / 70 to 76 KIAS depending upon the amount of ice accumulation
m.	Land	In level attitude

#### WARNING

Flights in icing conditions are prohibited!  
If icing is formed on the wing leading edge, expect false indication of the airspeed, altitude, vertical speed and stall warning system!

#### CAUTION

With an ice accumulation of 6.4 mm / 0.25 inch or more on the wing leading edges, expect significantly higher power requirements, higher approach and stall airspeeds, increased vibration, worse climb characteristics and a longer landing roll.  
Missed approaches should be avoided whenever possible!

#### NOTE

When using the carburetor preheating, engine power will decrease due to hot air suction from the heat exchanger.

**3.11 Loss of Flight Controls**

**3.11.1 Aileron Control Failure**

a.	<b>ROLL</b> trim	As required
b.	Rudder control	As required
c.	<b>THROTTLE</b>	As required, carefully

**CAUTION**  
Avoid steep turns – more than 15° of bank!

**3.11.2 Elevator Control Failure**

a.	<b>THROTTLE</b>	As required, carefully
b.	<b>PITCH</b> trim	As required

If you cannot control the aircraft in the longitudinal direction by means of **PITCH** trim:

c.	Wing flaps	Carefully use for attitude change (use incremental positions of flaps if required by holding the flaps lever in desired position)
----	------------	---

If you cannot control the aircraft in the longitudinal direction:

d.	<b>RESCUE SYSTEM</b> actuator	ACTIVATE according to Chapter 3.13.4
----	-------------------------------	--------------------------------------

**WARNING**  
Extension of flaps causes the aircraft to become nose-heavy!  
Do not retract the flaps to the previous position at low airspeed close to the stall!

**CAUTION**  
Avoid steep turns – more than 15° of bank!  
Avoid abrupt maneuvers!  
Longer runway will be necessary for landing!

**3.11.3 Rudder Control Failure**

a.	Aileron control	As required, carefully
b.	<b>THROTTLE</b>	As required, carefully

**CAUTION**  
Avoid steep turns – more than 15° of bank!

## 3.12 Spins

### 3.12.1 Inadvertent spin

The WT9 Dynamic LSA is not approved for spins. Although the stall warning system makes accidental entry into a spin extremely unlikely, it is possible. The best means for preventing an inadvertent stall and spin entry is good airmanship, monitoring of the airspeed and avoiding abrupt maneuvers at low speed and altitude.

**WARNING**

Intentional spins are prohibited!

**WARNING**

Do not waste time and altitude trying to recover from spin before activating of EPS!

For recovery from an inadvertent spin the following procedure must be used:

- |                                     |                                      |
|-------------------------------------|--------------------------------------|
| a. <b>RESCUE SYSTEM</b><br>actuator | ACTIVATE according to Chapter 3.13.4 |
|-------------------------------------|--------------------------------------|

### 3.13 Other Emergencies

#### 3.13.1 Vibrations

The power plant can be the source of the vibrations.

a.	Engine speed	Reduce to minimize the vibrations
b.	Land	According to Chapter 3.8.1

#### CAUTION

Be prepared for engine failure and emergency landing without engine power according to Chapter 3.8.3!

#### 3.13.2 Fuel Selector Failure

Due to **FUEL** selector failure, it may be impossible to switch to the desired tank or shut off the fuel supply.

a.	<b>LH FUEL RES. / RH FUEL RES.</b> warning lamp	Use for monitoring the fuel low level; red warning lamp will be illuminated when 16 liters of fuel remain in the fuel tank
b.	Land	According to Chapter 3.8.1

#### CAUTION

Be prepared for engine failure and emergency landing without engine power according to Chapter 3.8.3!

#### 3.13.3 Unsecured Canopy

If the „Before takeoff“ checklist is not performed properly (see Chapter 4.9, step 9), there is a danger of partial canopy latching and insufficient locking. For detailed information on canopy operation refer to Chapter 7.12. Due to airflow and the function of gas struts the canopy can open spontaneously during straight line flight or sideslip. Partially latched and insufficiently locked canopy will be indicated by increased noise due to the airflow passing through the gap between fuselage and canopy. The canopy can be closed safely during straight line flight without sideslip as follows, according to the appropriate stage of flight:

##### 3.13.3.1 During Takeoff Roll

a.	Takeoff roll	Abort
b.	Canopy	Latch and lock by normal procedure after stopping. (Pull down the canopy handle and check the red ring indicates latched and locked position) (see Chapter 7.12).

### 3.13.3.2 After Lift Off or during Climbing

a. Takeoff	Abort (if sufficient RWY is remaining), otherwise continue
b. Climb	Climb to safety altitude
c. Flight	Keep straight level flight without sideslip and carry out procedure according to Chapter 3.13.3.3

### 3.13.3.3 During Level Flight

a. Sliding windows	OPEN
b. Airspeed	120 – 130 IAS / 65 – 70 KIAS
c. Control stick	Hold with one hand
d. Canopy handle	Pull down for canopy latching and locking (see Chapter 7.12)
e. Canopy latching and locking	Check by canopy frame and red ring position
f. Sliding windows	CLOSE

### WARNING

During sideslip (incorrect turn – slipping turn, skidding turn, and sideslip during approach) with the canopy partially latched and locked, due to asymmetrical flow over the fuselage, the canopy will be carved through the gap and subsequently will be fully opened with contribution of gas struts. The canopy will become a braking shield, which will cause abnormal aircraft descent due to increased drag!



### 3.13.4 Emergency Parachute System Activation

The aircraft is equipped with Emergency Parachute System. (EPS) should be activated in the event of a life-threatening emergency where EPS deployment is safer than continued flight and landing.

Occupants must be in the emergency landing body braced position before touchdown. After touchdown, maintain the emergency landing body position until the aircraft is completely stopped.

The recommended emergency landing body position is assumed with the both hands placed on the lap, one wrist clasped with the opposite hand and with the upper torso erect against the backrest.

Follow this procedure when deciding to deploy EPS:

a.	Impact area	Determine (flat terrain, no trees or obstacles – if possible)
b.	Airspeed	Minimum, if possible
c.	<b>IGNITION</b>	OFF both circuits (if time and altitude permit)
d.	<b>RESCUE SYSTEM</b> actuator protector	Lift (see Chapter 7.22, Fig. 7-34)
e.	<b>RESCUE SYSTEM</b> actuator	PULL STRONGLY (see Chapter 7.22, Fig. 7-34) (force up to 12 kg / 26.5 lb or greater may be required)

After deployment:

f.	<b>FUEL PUMP</b>	OFF
g.	<b>FUEL</b> selector	<b>OFF</b>
h.	Starter key	<b>OFF</b>
i.	<b>MASTER SWITCH</b>	OFF
j.	Safety harness	Fasten
k.	Emergency landing body position	Assume

#### WARNING

EPS deployment results in loss of the airframe. Depending on high deployment speed, low altitude, rough terrain or high wind conditions may result in severe injury or death of the occupants!

#### WARNING

If the aircraft enters an unusual attitude from which the recovery is not expected before ground impact, immediate deployment of EPS is required!

**WARNING**

The extreme emergency in which the EPS must be activated requires that it be activated in a timely manner. Do not wait until the aircraft has exceeded the airspeed and load factor operating envelope, is at an altitude which does not allow the parachute to fully deploy prior to ground impact, or is in an extreme attitude!

**WARNING**

If the aircraft is controllable and structurally capable of flying to a safe landing site, the EPS should not be activated!

**WARNING**

Minimum height for EPS activation is 660 ft (200 m) AGL and maximum airspeed is 303 IAS / 164 KIAS!

**CAUTION**

Ground impact is expected to be equivalent to touchdown from a height of approximately 8.2-9.8 ft (2.5-3.0 m). Occupants must assume emergency landing body position before touchdown!

**CAUTION**

The EPS is not intended to be a substitute for good pilot judgment, skills and training, proper pre-flight planning, proper aircraft maintenance and pre-flight inspections, and safe aircraft operations!

**NOTE**

The recommended emergency landing body position is assumed with both hands placed on the lap, one wrist clasped with the opposite hand and with the upper torso erect against the backrest.

# 4 NORMAL PROCEDURES

## TABLE OF CONTENTS

<b>4.1</b>	<b>GENERAL .....</b>	<b>4-3</b>
<b>4.2</b>	<b>AIRSPEEDS FOR NORMAL OPERATION.....</b>	<b>4-3</b>
<b>4.3</b>	<b>PRE-FLIGHT INSPECTION .....</b>	<b>4-4</b>
<b>4.4</b>	<b>BEFORE ENGINE STARTING.....</b>	<b>4-10</b>
<b>4.5</b>	<b>USE OF EXTERNAL POWER .....</b>	<b>4-10</b>
<b>4.6</b>	<b>ENGINE STARTING .....</b>	<b>4-11</b>
<b>4.7</b>	<b>BEFORE TAXIING.....</b>	<b>4-13</b>
<b>4.8</b>	<b>TAXIING.....</b>	<b>4-13</b>
<b>4.9</b>	<b>BEFORE TAKEOFF .....</b>	<b>4-14</b>
4.9.1	Ignition and Engine Ground Tests .....	4-14
4.9.2	Before Line Up.....	4-15
<b>4.10</b>	<b>TAKEOFF.....</b>	<b>4-16</b>
4.10.1	Normal and Short Field Takeoff .....	4-16
4.10.2	Soft Field Takeoff .....	4-17
<b>4.11</b>	<b>CLIMB.....</b>	<b>4-18</b>
<b>4.12</b>	<b>CRUISE.....</b>	<b>4-18</b>
<b>4.13</b>	<b>DESCENT.....</b>	<b>4-19</b>
<b>4.14</b>	<b>APPROACH .....</b>	<b>4-19</b>
<b>4.15</b>	<b>LANDING .....</b>	<b>4-20</b>
4.15.1	Normal Landing .....	4-20
4.15.2	Short Field Landing.....	4-21
4.15.3	Soft Field Landing .....	4-21
4.15.4	Balked Landing .....	4-22
<b>4.16</b>	<b>AFTER LANDING.....</b>	<b>4-22</b>
<b>4.17</b>	<b>SHUTDOWN.....</b>	<b>4-23</b>



# WT9 Dynamic LSA / Club

## Pilot's Operating Handbook

AS-POH-01-000

<b>4.18</b>	<b>ENVIRONMENTAL CONSIDERATION .....</b>	<b>4-23</b>
4.18.1	Cold Weather Operation .....	4-23
4.18.2	Hot Weather Operation .....	4-23
<b>4.19</b>	<b>OTHER NORMAL PROCEDURES .....</b>	<b>4-24</b>
4.19.1	Stall.....	4-24
4.19.2	Sideslip .....	4-25
4.19.3	Crosswind Takeoff .....	4-26
4.19.4	Crosswind Landing .....	4-26
<b>4.20</b>	<b>NOISE CHARACTERISTICS .....</b>	<b>4-27</b>

### 4.1 General

This chapter provides checklists and recommended procedures for normal operation of the aircraft. Normal procedures associated with equipment can be found in the Chapter 9.

### 4.2 Airspeeds for Normal Operation

Unless stated otherwise, the following speeds are based on maximum takeoff weight 600 kg / 1323 lb.

Takeoff rotation	<b>FLAPS 1</b>	65 – 70 IAS	35 – 38 KIAS
Climb	Normal	122 – 127 IAS	66 – 69 KIAS
	Best rate of climb speed (at sea level)	127 IAS	69 KIAS
	Best angle of climb speed (at sea level)	100 IAS	54 KIAS
Landing approach	<b>FLAPS 1, FLAPS 2</b>	120 – 130 IAS	65 – 70 KIAS
Balked landing	Full power ( <b>FLAPS 1</b> )	110 – 130 IAS	60 – 70 KIAS
Rough air penetration	Maximum	218 IAS	118 KIAS
Demonstrated crosswind velocity	Takeoff	8.3 m/s	16.1 knots
	Landing	7.5 m/s	14.6 knots

### 4.3 Pre-Flight Inspection

It is most important to perform a pre-flight inspection carefully to prevent possible troubles. The pre-flight inspection is essential for flight safety. Pre-flight inspection procedure is shown on Fig. 4-1. Review your flight plan and calculate the weight and balance before each flight.

**WARNING**  
If any problems are found they must be rectified before flying!

**WARNING**  
Remove the pitot probe cover before flight!

**CAUTION**  
Pay special attention to the parts, which are affected by vibrations and high temperatures!

**NOTE**  
The word "condition" in the pre-flight inspection means a visual inspection of surface for damage, deformations, scratching, chafing, evidence of delamination, corrosion or other damages, which may lead to flight safety degradation.

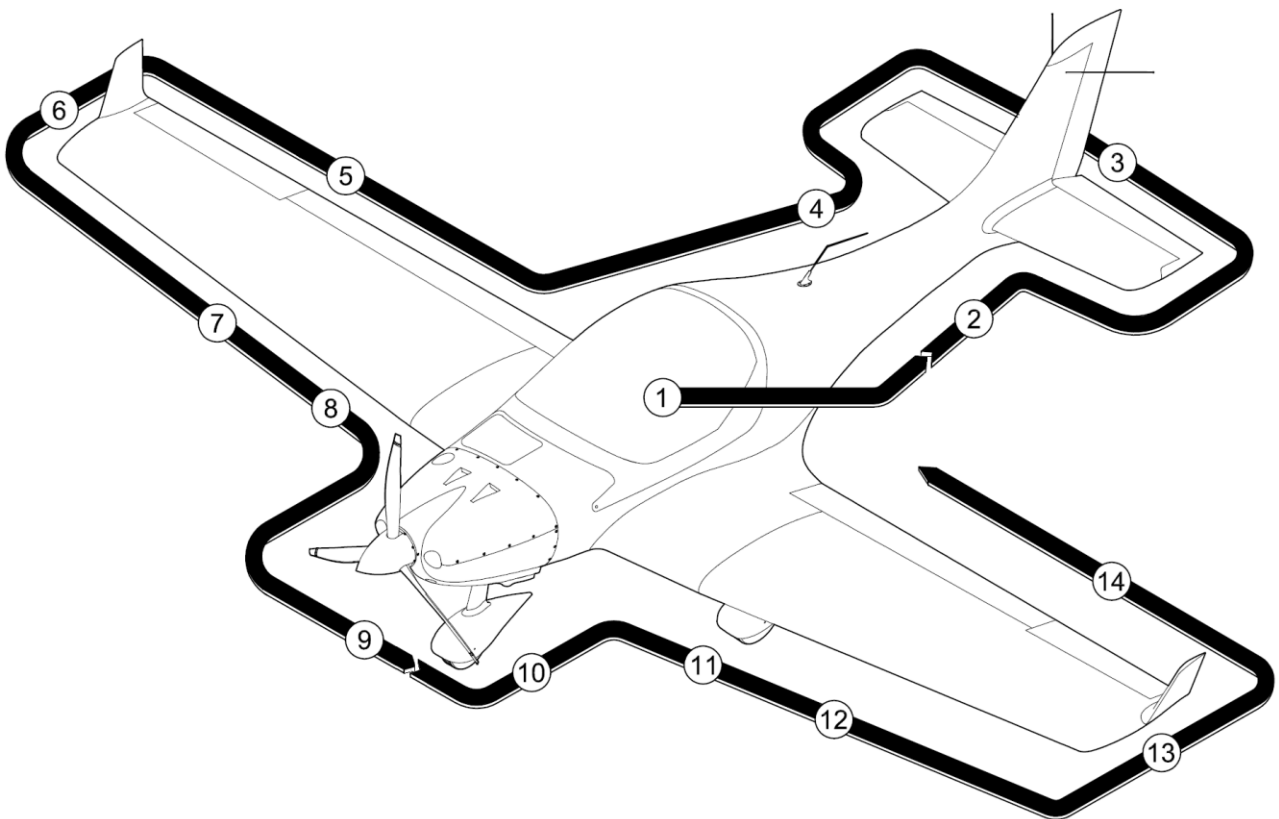

Fig. 4-1 Pre-flight inspection procedure

### 1 CABIN

a.	Aircraft documents	Check, on board
b.	Baggage	Restrained
c.	Flight controls	Freedom and proper direction of movement
d.	<b>IGNITION</b>	OFF both circuits
e.	<b>MASTER SWITCH</b>	OFF
f.	<b>THROTTLE</b>	Freedom of movement, set IDLE
g.	<b>CARBUR. PREHEATING</b>	Freedom of movement, set CLOSED
h.	<b>CABIN VENTILATION</b>	Freedom of movement
i.	<b>CABIN HEATING</b>	Freedom of movement
j.	<b>FUEL</b> selector	Freedom of movement
k.	<b>CHOKE</b>	Freedom of movement, set CLOSED
l.	<b>RESCUE SYSTEM</b> actuator	Check the condition of actuator attachment, arming and locking, service dates for expiration
m.	Circuit breakers	Pressed in
n.	Brake	Freedom of movement, function, set <b>PARK</b>
o.	Wing flaps	Freedom of movement, set <b>FLAPS 3</b> , check locked
p.	<b>MASTER SWITCH</b>	ON
q.	<b>TEST</b> button	Press, check warning and check lamps illumination, control stick shaker
r.	<b>AVIONICS</b>	ON
s.	Radio	ON, check, then OFF
t.	XPDR	ON, check, then OFF
u.	Intercom	Check
v.	PFD, MFD screen	Check
w.	Fuel quantity	Check (if shown 45+, use a dipstick for appropriate fuel tank)
x.	Voltmeter	Check, min. 11.5 V
y.	Instruments	Check
z.	<b>LAND</b> lights	ON, check function
aa.	<b>NAV / ACL</b> lights	ON, check function
bb.	<b>PITCH</b> trim and <b>ROLL</b> trim	Check movement and indication
cc.	All switches	OFF
dd.	<b>MASTER SWITCH</b>	OFF
ee.	Canopy	Cleanness of glass, canopy lock function
ff.	Safety harness	Inspect

### 2 LEFT FUSELAGE

a.	Left wing walk	Condition
b.	Surface	Condition
c.	COMM antenna (top)	Condition, attachment
d.	XPDR antenna (underside)	Condition, attachment
e.	FLARM antenna (underside) – if installed	Condition, attachment

### 3 EMPENNAGE

a.	VOR antenna	Condition, attachment
b.	Horizontal and vertical stabilizers	Condition
c.	Elevator	Condition, freedom of movement, without excessive play
d.	Rudder	Condition, without excessive play
e.	Elevator / rudder attachment	Secured
f.	Elevator / rudder sealing tapes	All in place, condition, attachment

### 4 RIGHT FUSELAGE

a.	Right wing walk	Condition
b.	Surface	Condition

### 5 RIGHT WING TRAILING EDGE

a.	Wing flap	Condition, without excessive play
b.	Wing flap attachment	Secured
c.	Aileron	Condition, remove control locks if installed, freedom of movement, without excessive play
d.	Aileron attachment	Secured
e.	Trim tab and attachment	Condition, without excessive play, secured
f.	Aileron sealing tapes	All in place, condition, attachment

### 6 RIGHT WING TIP

a.	Winglet	Condition
b.	NAV / ACL light	Condition, attachment



### 7 RIGHT WING LEADING EDGE

a.	Surface	Condition
b.	Pitot probe	Remove cover, condition, check for blockage
c.	Leading edge and stall strips	Condition, attachment, cleanness
d.	Fuel tank cap	Condition, check quantity of fuel by means of dipstick and secure
e.	Inspection hole cover	Installed
f.	Tie-down ropes	Remove
g.	Fuel drains (2 underside)	Drain and sample (see Chapter 8.3.2), check for leaks after draining

### 8 RIGHT MAIN LANDING GEAR

a.	Wheel fairing	Condition, attachment, accumulation of debris
b.	Main gear leg	Condition, attachment
c.	Inspection hole cover	Installed
d.	Brakes	Condition, fluid leaks
e.	Tire	Condition, inflation, wear
f.	Chocks	Remove

### 9 POWER PLANT

a.	Propeller	Condition (check for nicks and damage), attachment, secured
b.	Spinner	Condition, attachment
c.	Air inlets	Unobstructed
d.	Oil cowl door	OPEN
e.	Operating fluids	Check leaks
f.	Oil tank cap	OPEN
g.	Engine compression	Crank the propeller by hand several times until a noticeable gurgle is heard; Check for excessive resistance and normal compression
h.	Oil quantity	Check the level with a dipstick and replenish as required (see Chapter 8.3.3)
i.	Coolant quantity	Check level and replenish as required (see Chapter 8.3.4)
j.	Exhaust system	Condition, attachment
k.	Engine compartment	Check visually accessible areas
l.	Hoses, wires, plugs	Condition of hoses and attachment, condition and integrity of wires and plugs
m.	Lower engine cowlings	Condition, attachment
n.	Landing lights	Condition, attachment
o.	Oil cowl door	CLOSE

### WARNING

Never crank the propeller by hand with **IGNITION** switches ON!  
Before cranking the propeller, ensure that nobody is in the cockpit!

### WARNING

Do not replenish the coolant if the engine is hot.  
Always let the engine cool down to ambient temperature!

### CAUTION

The propeller must be grabbed by the blade surface every time!

#### 10 NOSE LANDING GEAR

a.	Tow bar	Remove and stow
b.	Wheel fairing	Condition, attachment, accumulation of debris
c.	Nose gear leg	Condition, attachment, suspension check
d.	Tire	Condition, inflation, wear

#### 11 LEFT MAIN LANDING GEAR

a.	Wheel fairing	Condition, attachment, accumulation of debris
b.	Main gear leg	Condition, attachment
c.	Inspection hole cover	Installed
d.	Brakes	Condition, fluid leaks
e.	Tire	Condition, inflation, wear
f.	Chocks	Remove

#### 12 LEFT WING LEADING EDGE

a.	Fuel drains (2 underside)	Drain and sample (see Chapter 8.3.2), check for leaks after draining
b.	Tie-down ropes	Remove
c.	Inspection hole cover	Installed
d.	Fuel tank cap	Condition, check quantity of fuel by means of dipstick and secure
e.	Leading edge and stall strips	Condition, attachment, cleanness
f.	ACI stall warner	Attached, flap unobstructed
g.	Surface	Condition

### 13 LEFT WING TIP

a.	Winglet	Condition
b.	NAV / ACL light	Condition, attachment

### 14 LEFT WING TRAILING EDGE

a.	Aileron	Condition, remove control locks if installed, freedom of movement, without excessive play
b.	Aileron attachment	Secured
c.	Aileron sealing tapes	All in place, condition, attachment
d.	Wing flap	Condition, without excessive play
e.	Wing flap attachment	Secured

### 4.4 Before Engine Starting

a.	Ground equipment	Removed
b.	Pre-flight inspection	Performed
c.	Co-pilot (passenger)	Briefed
d.	Weight and balance	Verified within limits for takeoff and landing
e.	<b>RESCUE SYSTEM</b> actuator	Remove lock (see Chapter 7.22, Fig. 7-34)
f.	Safety harness	Adjust and lock, not twisted
g.	Wing flaps	<b>FLAPS 0</b>
h.	Brake	<b>MAX</b>

#### NOTE

Ensure that the co-pilot (passenger) has been briefed on smoking, safety harness, use of EPS, canopy opening, what to expect during an emergency and other safety recommendations.

### 4.5 Use of External Power

The aircraft is equipped with external power socket for connection to ground power unit. It is located on the left side under the instrument panel.

a.	External power source	Ensure that external power source is regulated to max. 12 V / 90 A DC
b.	<b>MASTER SWITCH</b>	Check OFF
c.	External power	Plug in external power source
d.	Engine start	Perform according to Chapter 4.6
e.	External power	Unplug external power source

#### WARNING

If the aircraft will be started using external power, keep all personnel and power unit cables clear of the propeller rotation plane!

#### CAUTION

Max. power source output connected to the external power socket for engine starting is limited to 12 V / 90 A DC!

#### CAUTION

Do not use external power to start the engine with a "dead" battery. Takeoff with a weak battery should be avoided. The battery must be maintained according to appropriate Aircraft Maintenance Manual procedures!

### 4.6 Engine Starting

a.	<b>FUEL</b> selector	<b>LEFT</b> (if the fuel tank volume is 45+, see Chapter 7.16) or <b>RIGHT</b>
b.	<b>CHOKE</b> - cold engine - warm engine	OPEN (pull to open) CLOSE (push to close)
c.	<b>THROTTLE</b> - cold engine - warm engine	IDLE Slightly OPEN (5 mm of throttle controller travel)
d.	<b>MASTER SWITCH</b>	ON, wait until PFD and MFD start up
e.	Instruments	Check and set
f.	<b>NAV / ACL</b> lights	ON
g.	Starter key	<b>INST.</b>
h.	<b>FUEL PUMP</b>	ON, establish the fuel pressure and then OFF
i.	<b>IGNITION</b>	ON both circuits
j.	Propeller area	Clear
k.	Starter key	Hold <b>START</b> , after engine started release to <b>CHARGE</b>
As soon as engine runs:		
l.	<b>THROTTLE</b>	Adjust to achieve smooth running at approx. 2500 rpm, then decrease to approx. 2000 rpm
m.	Oil pressure	Minimum 2.00 bar within maximum of 10 seconds; If not, shut down the engine and investigate the cause
n.	<b>CHARGE</b> warning lamp	Check OFF
o.	<b>CHOKE</b>	CLOSE and add throttle simultaneously
p.	<b>AVIONICS</b>	ON
q.	Radio	ON
r.	Transponder	ON, STBY or ALT (as required)

**WARNING**  
Never start the engine by hand!

**WARNING**  
Before engine starting ensure that the propeller area is clear!

**CAUTION**  
The starter should be activated for a maximum of 10 sec, followed by 2 min pause for starter cooling!

**CAUTION**

Do not actuate starter key as long as the engine is running. Wait until the engine is completely stopped!

**CAUTION**

After engine starting, if the oil pressure does not reach the minimum pressure 2.00 bar within 10 seconds, shut down the engine and investigate the cause! The loss of lubrication can cause severe engine damage!

**CAUTION**

At an engine start with low oil temperature, continue to observe the oil pressure as it could drop again due to the increased flow resistance in the suction line. The number of revolutions may be only so far increased that the oil pressure remains steady!

### 4.7 Before Taxiing

Before taxiing, start the warming up period at 2000 rpm for approx. 2 minutes and continue at 2500 rpm. Duration depends on ambient temperature. Monitor temperatures and pressures. Carburetor preheating may be opened to shorten the warming up period. Warm up the engine until the oil temperature reaches 50 °C according to following procedure:

a.	<b>CARBUR. PREHEATING</b>	As required
b.	<b>THROTTLE</b>	2000 rpm for 2 minutes, then continue at 2500 rpm
c.	Altimeter	Set
d.	Rudder pedals	Adjust
e.	<b>CARBUR. PREHEATING</b>	CLOSED

### 4.8 Taxiing

When taxiing, the direction of the aircraft is controlled by the rudder pedals which are connected to the nose wheel and rudder. Use the minimum power settings for taxi. Power settings for taxi on flat, smooth, hard surfaces is idle (min. 1400 rpm). Power settings for grassy, inclined, soft surfaces or when start motion is slightly above idle (1400 rpm). Control the taxi speed by means of power setting. Always taxi with the flaps retracted (**FLAPS 0**).

#### WARNING

Do not simultaneously increase power and apply brakes. The brake system may overheat and result in brake failure or brake fire!

#### NOTE

When taxiing, relieve the nose wheel load using elevator control.

### 4.9 Before Takeoff

Before takeoff the engine should be properly warmed. The engine oil temperature must reach min. 50 °C. Then the ignition and engine ground tests may be performed as follows:

#### 4.9.1 Ignition and Engine Ground Tests

a.	<b>CARBUR. PREHEATING</b>	Check CLOSED
b.	Brake	<b>MAX</b>
Ignition and engine ground tests:		
c.	<b>THROTTLE</b>	4000 rpm
d.	<b>IGNITION</b>	Switch OFF first ignition circuit, then back ON; Switch OFF second ignition circuit, then back ON; Engine speed drop with only one ignition circuit must not exceed 300 rpm; Max. difference of engine speed by use of either circuit A or B is 115 rpm
e.	<b>THROTTLE</b>	Short MAX
f.	Engine speed	Check, 5200 rpm ±200 rpm
g.	Engine parameters	Check
h.	<b>CARBUR. PREHEATING</b>	OPEN, check carburetor preheating function (engine speed drop min. 100 rpm); Then CLOSE
i.	<b>THROTTLE</b>	IDLE, check min. 1400 rpm

#### WARNING

Before engine full-power ground test ensure that the propeller area is clear!

#### WARNING

Position the aircraft so that the prop wash will not hurt any persons, or cause any damage! Never perform a ground test against any buildings or obstacles!

#### CAUTION

The engine full-power ground test should be performed with the aircraft heading upwind. Do not perform the engine full-power ground test on a gravel surface. The propeller may suck the gravel and damage the blades!



### CAUTION

After an engine full-power ground test, allow a short cooling run to prevent vapor formation in the cylinder head!

### CAUTION

When performing the engine full-power ground test on grassy or slick surface, the aircraft may move despite MAX brake being used!

#### 4.9.2 Before Line Up

a.	<b>RESCUE SYSTEM</b> actuator	Check removed lock (see Chapter 7.22, Fig. 7-34)
b.	Controls	Freedom of movement
c.	<b>PITCH</b> trim and <b>ROLL</b> trim	Set neutral
d.	Wing flaps	<b>FLAPS 1</b> , check locked
e.	<b>CHOKE</b>	Check CLOSED
f.	<b>CARBUR. PREHEATING</b>	Check CLOSED
g.	<b>FUEL PUMP</b>	ON
h.	<b>LAND</b> lights	ON
i.	<b>NAV / ACL</b> lights	Check ON
j.	<b>AVIONICS</b>	Check ON and set
k.	Transponder	ALT
l.	Engine parameters	Check
m.	Warning and check lamps	Check
n.	Circuit breakers	Check pressed in
o.	Canopy	Latched and locked – verify by pressing upwards on the handle (see Chapter 7.12)
p.	Safety harness	Fasten
q.	Wind	Check windsocks

### 4.10 Takeoff

The engine should be properly warmed up before takeoff (oil temperature min. 50 °C).

For takeoff over a gravel surface, apply the throttle slowly and the gravel will be blown behind the propeller rather than pulled into it.

**WARNING**

Takeoff is prohibited if:

- Engine is running unsteadily, roughly or with vibrations!
- Engine parameters are beyond operational limits!
- Aircraft systems (e. g. brakes, flight controls or avionics) are working incorrectly!
- Canopy is not properly latched and locked!
- Weight and balance for both takeoff and landing is out of approved limits!
- There is a frost, ice, snow or other contamination on fuselage, wings, stabilizers and control surfaces!

#### 4.10.1 Normal and Short Field Takeoff

a.	Brake	<b>MAX</b>
b.	<b>THROTTLE</b>	MAX
c.	Engine parameters	Check
d.	Brake	Release
e.	Control stick	Slightly tail low
f.	Directional control	Maintain with rudder control
g.	Rotate	Smoothly at 68 – 70 IAS / 37 – 38 KIAS
h.	Airspeed	100 IAS / 54 KIAS for best angle of climb 127 IAS / 69 KIAS for best rate of climb

### 4.10.2 Soft Field Takeoff

For takeoffs from a soft or rough field, it is recommended to lift the aircraft off the ground as soon as practical. The aircraft should be leveled after lift off immediately to accelerate.

a.	Brake	Release
b.	<b>THROTTLE</b>	Smoothly MAX
c.	Engine parameters	Check
d.	Control stick	Slightly tail low
e.	Directional control	Maintain with rudder control
f.	Rotate	Smoothly at 68 – 70 IAS / 37 – 38 KIAS
g.	Airspeed	100 IAS / 54 KIAS for best angle of climb 127 IAS / 69 KIAS for best rate of climb

### 4.11 Climb

Climb is performed with flaps retracted and maximum continuous power. For maximum rate of climb establish the best rate of climb. If an obstacle clearance is required using a steep climb angle, establish the best angle of climb speed.

a. <b>THROTTLE</b>	As required
b. Airspeed	100 IAS / 54 KIAS for best angle of climb 127 IAS / 69 KIAS for best rate of climb
c. Wing flaps	<b>FLAPS 0</b> slowly at safety altitude (not below 165 ft (50 m) AGL and 120 IAS / 65 KIAS)
d. <b>PITCH</b> trim and <b>ROLL</b> trim	As required
e. <b>FUEL PUMP</b>	OFF
f. <b>LAND</b> lights	OFF
g. Engine parameters	Monitor

	IAS	KIAS
Best angle of climb airspeed $V_x$ (at SL)	100 IAS	54 KIAS
Best rate of climb airspeed $V_y$ (at SL)	127 IAS	69 KIAS

#### CAUTION

If the coolant or oil temperature approaches or exceeds limits, reduce the climb angle to increase airspeed and possibly return within limits! If readings do not improve, troubleshoot causes other than high power setting at low airspeed!

### 4.12 Cruise

Normal cruising is performed in the airspeed range 180 – 210 IAS / 97 – 113 KIAS and engine speed range 4800 – 5500 rpm. In the case of turbulence reduce the cruising airspeed below 218 IAS / 118 KIAS to avoid of aircraft overstressing.

a. <b>THROTTLE</b>	As required
b. <b>PITCH</b> trim and <b>ROLL</b> trim	As required
c. Engine parameters	Monitor
d. Fuel flow and fuel balance	Monitor

**4.13 Descent**

It is not advisable to reduce the engine power to idle when descending from a very high altitude. In such case the engine may become under-cooled and a loss of power may occur. It is recommended to descend at increased rpm (approximately 3000 rpm) and check the engine parameters are within permitted limits.

For increasing the rate of descent, it is recommended to extend the wing flaps.

a.	<b>THROTTLE</b>	As required
b.	Airspeed	As required
c.	<b>PITCH</b> trim and <b>ROLL</b> trim	As required
d.	Engine parameters	Monitor

**WARNING**

When descending with flaps extended, do not exceed  $V_{FE}$ !

**CAUTION**

Engine undercooling and loss of power may occur when descent engine power is set to idle! Increase the engine power during descent to keep the engine parameters within permitted limits!

**4.14 Approach**

a.	Wing flaps	As required, check locked
b.	Airspeed	120 – 130 IAS / 65 – 70 KIAS
c.	<b>PITCH</b> trim and <b>ROLL</b> trim	As required
d.	<b>THROTTLE</b>	As required
e.	Engine parameters	Check
f.	<b>FUEL</b> selector	Fullest tank
g.	<b>FUEL PUMP</b>	ON
h.	<b>LAND</b> lights	ON
i.	Safety harness	Fasten

### 4.15 Landing

**WARNING**  
Do not extend the flaps at speed above  $V_{FE}$ !

**WARNING**  
When setting the flaps position **FLAPS 1**, **FLAPS 2** always ensure that the flap lever is properly locked! If not locked properly, the flaps may retract inadvertently, which will cause the aircraft to pitch the nose up and lose of airspeed quickly!

**CAUTION**  
Extending the flaps significantly increase the nose-heavy attitude! Always extend the flaps gradually through incremental positions of the flaps lever! At each incremental position, trim the aircraft appropriately!

**NOTE**  
Always extend the flaps gradually through incremental positions and trim the aircraft appropriately. Optimum airspeed for flaps extension is:  
**FLAPS 1** at 130 IAS / 70 KIAS  
**FLAPS 2** at 120 IAS / 65 KIAS

#### 4.15.1 Normal Landing

Landing approach is conducted at a small glide slope angle due to the long distance of the float before touchdown.

a.	Wing flaps	<b>FLAPS 2</b> , extend gradually, check locked
b.	Airspeed	120 – 130 IAS / 65 – 70 KIAS
c.	<b>PITCH</b> trim and <b>ROLL</b> trim	As required
d.	<b>THROTTLE</b>	IDLE
e.	Flare	Begin approximately 7 - 10 ft (2 - 3 m) above ground
f.	Touchdown	Perform on the main wheels first; the nose wheel should be lowered smoothly to the runway as airspeed is diminished
g.	Directional control	Maintain with rudder control
h.	Brake	As required
i.	After landing	Perform according to Chapter 4.16

### 4.15.2 Short Field Landing

Landing approach is conducted at a small glide slope angle due to the long distance of the float before touchdown.

a.	Wing flaps	<b>FLAPS 2</b> , extend gradually, check locked
b.	Airspeed	110 – 115 IAS / 59 – 62 KIAS
c.	<b>PITCH</b> trim and <b>ROLL</b> trim	As required
d.	<b>THROTTLE</b>	IDLE
e.	Flare	Begin approximately 7 - 10 ft / 2 - 3 m above ground
f.	Touchdown	Perform on the main wheels first; the nose wheel should be lowered smoothly to the runway as airspeed is diminished
g.	Directional control	Maintain with rudder control
h.	Wing flaps	<b>FLAPS 0</b>
i.	Brake	Apply heavily
j.	After landing	Perform according to Chapter 4.16

#### NOTE

For maximum brake effectiveness, retract the flaps, hold the control stick full backward and apply max. braking without skidding.

### 4.15.3 Soft Field Landing

a.	Wing flaps	<b>FLAPS 2</b> , extend gradually, check locked
b.	Airspeed	120 – 130 IAS / 65 – 70 KIAS
c.	<b>PITCH</b> trim and <b>ROLL</b> trim	As required
d.	<b>THROTTLE</b>	IDLE
e.	Flare	Begin approximately 7 - 10 ft (2 - 3 m) above ground
f.	Touchdown	Perform as gently as possible on the main wheels first; the nose wheel should be lowered smoothly to the runway as airspeed is diminished
g.	Directional control	Maintain with rudder control
h.	Brake	Apply gently
i.	After landing	Perform according to Chapter 4.16

### 4.15.4 Balked Landing

a.	<b>THROTTLE</b>	Smoothly MAX
b.	Wing flaps	<b>FLAPS 1</b> slowly, check locked
c.	Airspeed	100 IAS / 54 KIAS for best angle of climb 127 IAS / 69 KIAS for best rate of climb
d.	Wing flaps	<b>FLAPS 0</b> slowly at safety altitude (not below 165 ft (50 m) AGL and 120 IAS / 65 KIAS)
e.	<b>PITCH</b> trim and <b>ROLL</b> trim	As required

#### NOTE

A thrust yawing moment is manifested in the case of the rapid full throttle application.

### 4.16 After Landing

a.	<b>THROTTLE</b>	Adjust for taxiing
b.	Wing flaps	<b>FLAPS 0</b>
c.	<b>PITCH</b> trim and <b>ROLL</b> trim	Set neutral
d.	<b>FUEL PUMP</b>	OFF
e.	<b>LAND</b> lights	OFF
f.	Transponder	STBY
g.	Taxiing	To the parking position

#### WARNING

Do not simultaneously increase power and apply brakes!  
The brake system may overheat and result in brake failure  
or brake fire!

#### NOTE

When taxiing, relieve the nose wheel load using elevator control.



### 4.17 Shutdown

a.	Brake	<b>PARK</b>
b.	<b>THROTTLE</b>	IDLE
c.	Radio	OFF
d.	Transponder	OFF
e.	<b>AVIONICS</b>	OFF
f.	<b>IGNITION</b>	OFF the first circuit, after 2-3 s OFF the second circuit
g.	Starter key	<b>OFF</b>
h.	<b>MASTER SWITCH</b>	OFF
i.	<b>NAV / ACL</b> lights	OFF
j.	<b>RESCUE SYSTEM</b> actuator	Install lock (see Chapter 7.22, Fig. 7-34)

#### CAUTION

Do not park the aircraft in direct sunlight with the canopy left open (see Chapter 8.2.2)!

#### NOTE

Canopy cover prevents the effects of the sun.

### 4.18 Environmental Consideration

#### 4.18.1 Cold Weather Operation

It is recommended to preheat the engine if the outside temperature falls below +5 °C. Use a suitable air heater. Temperature of hot air should not exceed 100 °C. Preheat until coolant and oil temperature exceed +20 °C.

Before engine starting remove ice from the aircraft surfaces, check the free movement of control surfaces and flaps. Also check and remove frost, ice, snow and any other contamination from wheels, wheel brakes and wheel fairings.

In the case of low battery an external power source may be used. Plug in the external power source to the socket in the cabin. Keep the cables and all personnel clear of propeller rotation plane during starting and disconnecting of external power source.

#### WARNING

When the aircraft will be started using external power, keep all personnel and power unit cables clear of the propeller!

#### 4.18.2 Hot Weather Operation

Avoid prolonged engine operation on the ground.

### 4.19 Other Normal Procedures

#### 4.19.1 Stall

The stall speeds are presented in the Chapter 5.

When the airspeed is slowly reduced, an imminent stall is noticed by vibrations felt in the seat. To prevent an inadvertent stall, the aircraft is equipped with two independent stall warning systems. First system is triggered by ADAHRS module of Dynon SkyView system and has aural indication (headset sound) and visual indication (EFIS screen indicator). Second system is triggered by ACI stall warner and has tactile indication (control stick shaker), aural indication (buzzer), visual indication (**STALL** warning lamp). The stall warning triggers approximately 9-19 km/h (5 – 10 kts) before the stall occurs.

The best means for preventing an inadvertent stall and spin entry is good airmanship, monitoring of the airspeed and avoiding abrupt maneuvers at low speed and altitude.

For recovery from a stall or approaching stall the following procedure should be used:

a. Elevator control	Push
b. <b>THROTTLE</b>	Add power smoothly to regain the airspeed
c. Ailerons / rudder control	Correct bank to maintain wing leveled

#### **WARNING**

If held in the stall intentionally, the aircraft may eventually rapidly bank to the side!

#### **WARNING**

Do not add the power rapidly during stall to avoid of sudden bank of aircraft to the side!

**4.19.2 Sideslip**

The sideslip is usually used during approach to landing with airspeed 120 IAS / 65 KIAS and flaps in position **FLAPS 2**. During the sideslip maneuver the fuel in the fuel tanks shifts laterally. In the fuel tank that is lower during the sideslip, the fuel shifts towards the wingtip and drains from the fuel outlet at the root rib (Fig. 4-2, A). In the case of prolonged side slip, when the **FUEL** selector is set to the lower fuel tank, there is a potential risk of fuel shortage. The fuel shortage may cause the engine to stop. Therefore, the fuel tank, which is higher, must be always selected during the sideslip.

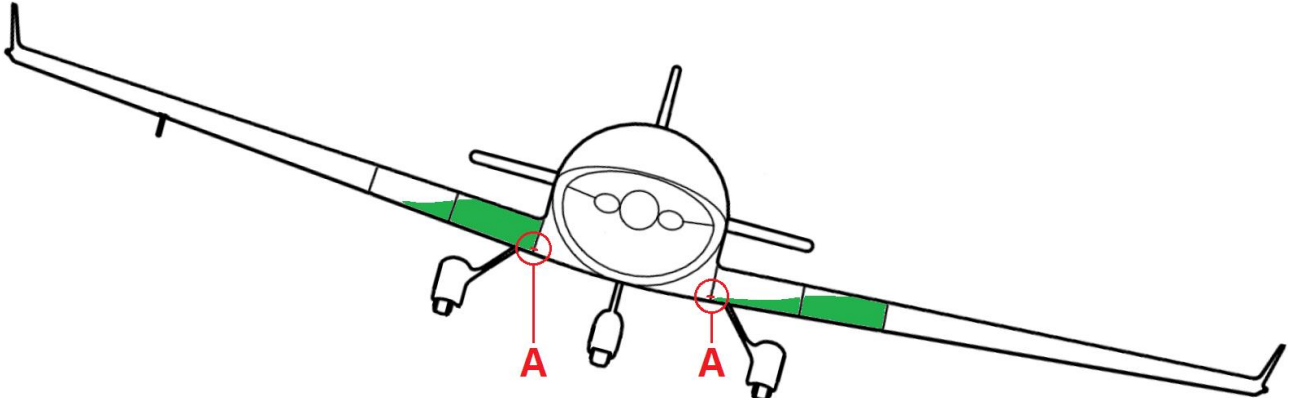

Fig. 4-2 Shifting of fuel in the fuel tanks during sideslip

**WARNING**

In a prolonged sideslip, the fuel in the lower wing tank will shift towards the wingtip and may cause fuel shortage to the engine!  
Even short-term fuel shortage may cause the engine to stop immediately!

In a sideslip, always set the higher wing tank on the **FUEL** selector!  
(e.g. LEFT SLIP<sup>1</sup> => **RIGHT TANK**, RIGHT SLIP<sup>2</sup> => **LEFT TANK**)

<sup>1</sup> left aileron, right rudder  
<sup>2</sup> right aileron, left rudder

Using engine power during slip / skid conditions may induce an oscillating regime known as Dutch roll. For recovery from a Dutch roll the following procedure should be used:

a.	Rudder control	Slightly decrease rudder deflection
b.	Aileron control	Keep deflected
After the oscillations have stopped:		
c.	Sideslip	Continue or recover normal flight

**CAUTION**

Using power setting other than IDLE at sideslip may cause an oscillation known as a Dutch roll! It is prohibited to perform sideslip with the power setting other than IDLE!

**NOTE**

If the Dutch roll has occurred, only slight decrease of rudder deflection is required to recover. Sideslip may be continued normally afterwards.

### 4.19.3 Crosswind Takeoff

Takeoffs under strong crosswind conditions are performed with the flaps setting in position **FLAPS 1** and the ailerons partially deflected into the wind. The aircraft is accelerated to airspeed slightly higher than normal, then the elevator control is used quickly, but carefully to lift the aircraft off the ground and prevent the possibility of setting back onto the runway while drifting.

When clear of the ground, make a coordinated turn into the wind to correct the drift and continue in takeoff.

a. Brake	Release
b. <b>THROTTLE</b>	Smoothly MAX
c. Engine parameters	Check
d. Control stick	Slightly tail low, ailerons into the wind
e. Directional control	Maintain with rudder control
f. Rotate	Quickly, but carefully at 73 – 75 IAS / 40 – 41 KIAS
g. Control stick / rudder control	Correct drift using ailerons and rudder
h. Airspeed	127 IAS / 69 KIAS

### 4.19.4 Crosswind Landing

When landing in a strong crosswind, use the minimum flap setting **FLAPS 1** or **FLAPS 2** position depending on the field length. Although the crab or combination method of drift correction may be used, the wing low method gives the best control.

After touchdown, hold a straight course with the steerable nose wheel, with aileron deflection as applicable and occasional braking if necessary.

a. Wing flaps	<b>FLAPS 1</b> or <b>FLAPS 2</b> (as appropriate), extend gradually, check locked
b. Airspeed	120 – 130 IAS / 65 – 70 KIAS
c. <b>PITCH</b> trim and <b>ROLL</b> trim	As required
d. Control stick / rudder control	Correct drift using ailerons and rudder
e. Flare	Begin approximately 7 - 10 ft / 2 - 3 m above ground
f. Touchdown	Perform on the main wheels first; the nose wheel should be lowered smoothly to the runway as airspeed is diminished
g. <b>THROTTLE</b>	IDLE
h. Directional control	Maintain with rudder control
i. Brake	As required
j. Wing flaps	<b>FLAPS 0</b>
k. After landing	Perform according to Chapter 4.16

### 4.20 Noise Characteristics

The noise level in accordance with requirements of the CS-36, Am. 2 (ICAO Annex 16, Volume I, Chapter 10 - 10.4 b) has been established to be 62.6 dB(A).

This page is left blank intentionally

# 5 PERFORMANCE

## TABLE OF CONTENTS

5.1	GENERAL .....	5-2
5.2	AIRSPEED CALIBRATION .....	5-3
5.3	STALL SPEEDS .....	5-5
5.4	TAKEOFF DISTANCE.....	5-7
5.5	RATE OF CLIMB.....	5-9
5.6	CRUISE PERFORMANCE AND FUEL CONSUMPTION .....	5-10
5.7	LANDING DISTANCE .....	5-12
5.8	DEMONSTRATED CROSSWIND PERFORMANCE.....	5-14

## 5.1 General

Chapter 5 provides performance data for takeoff, climb, cruise and landing. If not stated otherwise, the data in this chapter are valid for aircraft at maximum takeoff weight.

The performance tables on the Chapter 5 have been prepared to illustrate the performance you may expect from your aircraft as well as to assist you in precise flight planning. The data presented in these tables has been derived from test flights using an aircraft and engine in good operating condition, and was corrected to standard atmospheric conditions 15 °C and 1013.25 mbar at sea level.

The performance tables do not take into account the expertise of the pilot or the maintenance condition of the aircraft. The performance illustrated in the tables can be achieved if the indicated procedures are followed and the aircraft is in good maintenance condition.

Note that the flight duration data does not include unusable fuel. The fuel consumption during cruise is based on engine rpm and manifold pressure settings. Some undefined variables such as the operating condition of the engine, contamination of the aircraft surface, or turbulence could influence the flight distance and flight duration. For this reason, it is important that all available data is used when calculating the required amount of fuel for a flight.



### 5.2 Airspeed Calibration

**Associated conditions:**

Power for level flight or maximum continuous, whichever is less.

**Example:**

Indicated airspeed	125 km/h
Flaps	<b>FLAPS 1 (15°)</b>
Calibrated airspeed	126 km/h

**NOTE**  
Indicated airspeed assumes zero instrument error.

	IAS	CAS			
		FLAPS 0	FLAPS 1	FLAPS 2	FLAPS 3
		(0°)	(15°)	(24°)	(35°)
<b>V<sub>SO</sub></b>	<b>61</b>	-	-	-	<b>74</b>
	<b>64</b>	-	-	<b>75</b>	76
	<b>68</b>	-	<b>80</b>	79	79
<b>V<sub>S</sub></b>	<b>78</b>	<b>88</b>	88	87	88
	80	90	90	89	89
	85	94	94	93	94
	90	98	98	97	98
	95	103	102	101	102
	100	107	106	105	106
	110	115	114	114	114
	120	124	122	122	123
	130	132	130	130	131
<b>V<sub>FE</sub></b>	<b>140</b>	<b>141</b>	<b>138</b>	<b>139</b>	<b>139</b>
	150	150			
	160	158			
	170	167			
	180	176			
	190	185			
	200	194			
	210	203			
<b>V<sub>NO</sub></b>	<b>218</b>	<b>210</b>			
	220	212			
	230	221			
	240	231			
	250	240			
	260	249			
	270	259			
<b>V<sub>NE</sub></b>	<b>275</b>	<b>263</b>			

**Associated conditions:**

Power for level flight or maximum continuous, whichever is less.

**Example:**

Indicated airspeed	72 knots
Flaps	<b>FLAPS 1 (15°)</b>
Calibrated airspeed	72 knots

**NOTE**  
Indicated airspeed assumes zero instrument error.

	KIAS	KCAS			
		FLAPS 0	FLAPS 1	FLAPS 2	FLAPS 3
		(0°)	(15°)	(24°)	(35°)
<b>V<sub>SO</sub></b>	<b>33</b>	-	-	-	<b>40</b>
	<b>35</b>	-	-	<b>41</b>	41
	<b>37</b>	-	<b>43</b>	42	43
<b>V<sub>S</sub></b>	<b>42</b>	<b>48</b>	48	47	47
	45	50	50	50	50
	50	54	54	53	54
	55	58	58	57	58
	60	63	62	62	62
	65	67	66	66	66
	70	71	70	70	70
	75	75	74	74	74
<b>V<sub>FE</sub></b>	<b>76</b>	<b>77</b>	<b>75</b>	<b>75</b>	<b>76</b>
	85	84			
	90	88			
	95	93			
	100	98			
	105	102			
	110	106			
	115	111			
<b>V<sub>NO</sub></b>	<b>118</b>	<b>113</b>			
	120	116			
	125	120			
	130	125			
	135	130			
	140	134			
	145	139			
<b>V<sub>NE</sub></b>	<b>148</b>	<b>142</b>			

### 5.3 Stall Speeds

**Associated conditions:**

Weight 600 kg / 1323 lb  
 CG Most FWD at MTOW  
 Engine power at Idle  
 Wing level stall

**Example:**

Flaps **FLAPS 3 (35°)**

Stall speed 61 IAS / 74 CAS  
 33 KIAS / 40 KCAS

Wing level stalls	Flaps positions	IAS	CAS	KIAS	KCAS
Cruise	FLAPS 0 (0°)	78	88	42	48
Takeoff	FLAPS 1 (15°)	68	80	37	43
Landing – normal	FLAPS 2 (24°)	64	75	35	41
Landing – emergency	FLAPS 3 (35°)	61	74	33	40

**NOTE**

Maximum altitude lost during wing level stall is 300 ft.  
 Altitude loss is maximum value determined during flight tests using an average piloting technique.

**NOTE**

Airspeeds values may not be accurate at stall.

**Associated conditions:**

Weight 600 kg / 1323 lb  
 CG Allowable at MTOW  
 Engine power at From idle to 55% max.  
 continuous  
 Turning flight stall

**Example:**

Flaps **FLAPS 3 (35°)**

Stall speed 74 IAS / 85 CAS  
 40 KIAS / 46 KCAS

Turning flights (30° bank angle)	Flaps positions	IAS	CAS	KIAS	KCAS
Cruise	FLAPS 0 (0°)	83	92	45	50
Takeoff	FLAPS 1 (15°)	74	85	40	46
Landing – normal	FLAPS 2 (24°)				
Landing – emergency	FLAPS 3 (35°)				

**NOTE**

Maximum altitude lost during turning stall is 490 ft.  
 Altitude loss is maximum value determined during flight tests using an average piloting technique.

**NOTE**

The aircraft is not approved for pitch attitudes greater than 30°. The engine power must be reduced to 55% max. continuous power to avoid of exceeding 30° pitch angle.

**NOTE**

The stall speed increases as the angle of bank increases.

**NOTE**

Airspeeds values may not be accurate at stall.

### 5.4 Takeoff Distance

#### Associated conditions:

Weight	600 kg / 1323 lb
CG	Most FWD at MTOW
Flaps	<b>FLAPS 1</b> (15°)
Engine power	Max. takeoff
Procedure	Normal takeoff
Wind	Zero
Runaway slope	Zero
Speed V <sub>LOF</sub>	80 IAS / 43 KIAS
Speed V <sub>50</sub>	100 IAS / 54 KIAS

#### Example:

Pressure altitude	2000
Outside air temperature	15 °C
Runway	Paved (dry asphalt)
Tailwind	2 knots

Takeoff ground roll	593 ft / 181 m
Distance over 50 ft (15 m) obstacle	1136 ft / 346 m

#### NOTE

Poor maintenance condition of the aircraft, deviation from the given procedures as well as unfavourable outside conditions (rain, unfavourable wind conditions, including crosswind) could increase the takeoff distance considerably.

RWY surface:			PAVED (dry asphalt)				NON - PAVED (dry grass)			
ISA conditions			Ground roll		Takeoff distance over 50 ft (15 m)		Ground roll		Takeoff distance over 50 ft (15 m)	
Pressure altitude	Δ OAT ISA	OAT								
ft	°C	°C	ft	m	ft	m	ft	m	ft	m
<b>SL</b>	-30	-15	374	114	716	218	461	140	866	264
	-20	-5	403	123	773	236	497	152	935	285
	-10	5	434	132	832	253	535	163	1006	307
	<b>0</b>	<b>15</b>	<b>466</b>	<b>142</b>	<b>892</b>	<b>272</b>	<b>574</b>	<b>175</b>	<b>1079</b>	<b>329</b>
	10	25	499	152	955	291	615	187	1156	352
	20	35	533	162	1021	311	657	200	1234	376
	30	45	568	173	1088	332	700	213	1316	401
<b>2000</b>	-30	-19	419	128	803	245	517	158	972	296
	-20	-9	453	138	868	264	558	170	1050	320
	-10	1	488	149	935	285	601	183	1131	345
	<b>0</b>	<b>11</b>	<b>524</b>	<b>160</b>	<b>1004</b>	<b>306</b>	<b>646</b>	<b>197</b>	<b>1214</b>	<b>370</b>
	10	21	562	171	1076	328	692	211	1301	397
	20	31	601	183	1150	351	740	226	1391	424
	30	41	641	195	1227	374	790	241	1484	452

**Influence of wind:** - Add 5% to table distances for each 1 knots tailwind up to 10 knots.

RWY surface:			PAVED (dry asphalt)				NON - PAVED (dry grass)			
ISA conditions			Ground roll		Takeoff distance over 50 ft (15 m)		Ground roll		Takeoff distance over 50 ft (15 m)	
Pressure altitude	Δ OAT ISA	OAT								
ft	°C	°C	ft	m	ft	m	ft	m	ft	m
4000	-30	-23	471	144	902	275	581	177	1092	333
	-20	-13	510	155	976	297	628	191	1180	360
	-10	-3	549	167	1052	321	677	206	1273	388
	<b>0</b>	<b>7</b>	<b>591</b>	<b>180</b>	<b>1132</b>	<b>345</b>	<b>728</b>	<b>222</b>	<b>1369</b>	<b>417</b>
	10	17	634	193	1214	370	781	238	1468	448
	20	27	678	207	1299	396	836	255	1571	479
	30	37	724	221	1387	423	892	272	1678	511
6000	-30	-27	530	161	1015	309	653	199	1228	374
	-20	-17	574	175	1099	335	707	216	1329	405
	-10	-7	619	189	1186	362	763	233	1435	437
	<b>0</b>	<b>3</b>	<b>667</b>	<b>203</b>	<b>1277</b>	<b>389</b>	<b>822</b>	<b>250</b>	<b>1545</b>	<b>471</b>
	10	13	716	218	1371	418	882	269	1659	506
	20	23	767	234	1469	448	945	288	1777	541
	30	33	819	250	1570	478	1010	308	1899	579
8000	-30	-31	597	182	1143	348	735	224	1383	421
	-20	-21	647	197	1239	378	797	243	1499	457
	-10	-11	699	213	1340	408	862	263	1620	494
	<b>0</b>	<b>-1</b>	<b>754</b>	<b>230</b>	<b>1444</b>	<b>440</b>	<b>929</b>	<b>283</b>	<b>1746</b>	<b>532</b>
	10	9	810	247	1552	473	998	304	1877	572
	20	19	868	265	1663	507	1070	326	2012	613
	30	29	929	283	1779	542	1145	349	2152	656
10000	-30	-35	674	205	1290	393	830	253	1561	476
	-20	-25	731	223	1401	427	901	275	1695	516
	-10	-15	791	241	1516	462	975	297	1834	559
	<b>0</b>	<b>-5</b>	<b>854</b>	<b>260</b>	<b>1636</b>	<b>499</b>	<b>1052</b>	<b>321</b>	<b>1978</b>	<b>603</b>
	10	5	919	280	1760	536	1132	345	2129	649
	20	15	986	301	1889	576	1215	370	2284	696
	30	25	1056	322	2022	616	1301	396	2446	745

**Influence of wind:** - Add 5% to table distances for each 1 knots tailwind up to 10 knots.

### 5.5 Rate of Climb

#### Associated conditions:

Weight	600 kg / 1323 lb
CG	Most FWD at MTOW
Flaps	<b>FLAPS 0 (0°)</b>
Engine power	Max. takeoff

#### Example:

Pressure altitude	6000 ft
Outside air temperature	-7 °C

Climb speed 124 IAS / 67 KIAS

Rate of climb 846 fpm

Pressure altitude	Climb speed		Rate of climb (fpm)						
	IAS	KIAS	ISA - 30°C	ISA - 20°C	ISA - 10°C	ISA	ISA + 10°C	ISA + 20°C	ISA + 30°C
ft									
SL	<b>127</b>	<b>69</b>	1211	1166	1124	<b>1085</b>	1049	1015	983
<b>2000</b>	<b>126</b>	<b>68</b>	1135	1092	1052	<b>1015</b>	980	948	918
<b>4000</b>	<b>125</b>	<b>67</b>	1027	987	951	<b>917</b>	885	856	828
<b>6000</b>	<b>124</b>	<b>67</b>	914	879	846	<b>815</b>	787	760	735
<b>8000</b>	<b>123</b>	<b>66</b>	746	717	689	<b>664</b>	640	619	598
<b>10000</b>	<b>122</b>	<b>66</b>	563	540	519	<b>500</b>	482	465	450

Best angle of climb airspeed $V_x$ (at SL)	<b>100 IAS</b>	<b>54 KIAS</b>
Rate of climb at $V_x$ (at SL)	<b>985 fpm</b>	
Best rate of climb airspeed $V_y$ (at SL)	<b>127 IAS</b>	<b>69 KIAS</b>
Rate of climb at $V_y$ (at SL)	<b>1085 fpm</b>	

### 5.6 Cruise Performance and Fuel Consumption

**Associated conditions:**

Weight 600 kg / 1323 lb  
 Flaps **FLAPS 0 (0°)**  
 Winds Zero

**Example:**

Cruise pressure altitude 6000 ft  
 Engine speed 5000 rpm  
 .....  
 Airspeed 187 IAS / 183 CAS / 200 TAS  
 MAP 21.3 inHg  
 Fuel consumption 16.4 l/h  
4.33 U. S. gal/h

Pressure altitude	Engine speed	Airspeed			MAP	Fuel consumption	
		IAS	CAS	TAS		(l/h)	U. S. gal/h
ft	rpm				inHg		
2000	5 800	232	224	237	26.7	23.3	6.16
	5 500	223	215	228	25.8	21.3	5.63
	5 000	200	194	206	24.2	18.5	4.89
	4 800	190	185	196	23.5	17.2	4.54
	4 500	175	172	183	22.4	15.5	4.10
	4 300	165	163	172	21.6	14.5	3.83
4000	5 800	226	218	232	25.2	22.0	5.81
	5 500	216	209	222	24.4	20.4	5.39
	5 000	194	189	200	22.8	17.4	4.60
	4 800	184	180	191	22.2	16.3	4.31
	4 500	170	167	176	22.2	14.5	3.83
	4 300	160	158	168	20.5	13.6	3.59
6000	5 800	221	213	233	23.3	20.5	5.42
	5 500	211	204	222	22.6	19.0	5.02
	5 000	187	183	200	21.3	16.4	4.33
	4 800	178	175	191	20.7	15.3	4.04
	4 500	163	161	176	19.8	13.7	3.62
	4 300	153	153	167	19.2	12.6	3.33
8000	5 720	212	205	231	22.0	19.3	5.10
	5 500	201	195	220	21.4	18.0	4.76
	5 000	181	177	200	20.1	15.3	4.04
	4 800	172	169	191	19.6	14.2	3.75
	4 500	155	156	176	18.8	12.8	3.38
	4 300	145	146	157	18.3	11.8	3.12
10000	5 660	202	196	228	20.5	18.4	4.86
	5 500	192	187	218	19.9	16.9	4.46
	5 000	172	169	196	18.8	14.3	3.78
	4 800	163	161	187	18.4	13.4	3.54
	4 500	147	148	172	17.7	12.0	3.17
	4 300	138	140	163	17.3	11.2	2.96



# WT9 Dynamic LSA / Club

## Pilot's Operating Handbook



AS-POH-01-000

### Associated conditions:

Weight 600 kg / 1323 lb  
 Flaps **FLAPS 0 (0°)**  
 Winds Zero

### Example:

Cruise pressure altitude 6000 ft  
 Engine speed 5000 rpm  
 Airspeed 101 KIAS / 99 KCAS / 108 KTAS  
 MAP 21.3 inHg  
 Fuel consumption 16.4 l/h  
 4.33 U. S. gal/h

Pressure altitude	Engine speed	Airspeed			MAP	Fuel consumption	
		ft	rpm	KIAS		KCAS	KTAS
2000	5 800	125	121	128	26.7	23.3	6.16
	5 500	120	116	123	25.8	21.3	5.63
	5 000	108	105	111	24.2	18.5	4.89
	4 800	103	100	106	23.5	17.2	4.54
	4 500	94	93	99	22.4	15.5	4.10
	4 300	89	88	93	21.6	14.5	3.83
4000	5 800	122	118	125	25.2	22.0	5.81
	5 500	117	113	120	24.4	20.4	5.39
	5 000	105	102	108	22.8	17.4	4.60
	4 800	99	97.5	103	22.2	16.3	4.31
	4 500	92	90	95	22.2	14.5	3.83
	4 300	86	85.5	91	20.5	13.6	3.59
6000	5 800	119	115	126	23.3	20.5	5.42
	5 500	114	110	120	22.6	19.0	5.02
	5 000	101	99	108	21.3	16.4	4.33
	4 800	96	94.5	103	20.7	15.3	4.04
	4 500	88	87	95	19.8	13.7	3.62
	4 300	83	82.5	90	19.2	12.6	3.33
8000	5 720	114	110.5	125	22.0	19.3	5.10
	5 500	109	105.5	119	21.4	18.0	4.76
	5 000	98	95.5	108	20.1	15.3	4.04
	4 800	93	91	103	19.6	14.2	3.75
	4 500	84	84	95	18.8	12.8	3.38
	4 300	78	79	85	18.3	11.8	3.12
10000	5 660	109	106	123	20.5	18.4	4.86
	5 500	104	101	118	19.9	16.9	4.46
	5 000	93	91	106	18.8	14.3	3.78
	4 800	88	87	101	18.4	13.4	3.54
	4 500	79	80	93	17.7	12.0	3.17
	4 300	74	75.5	88	17.3	11.2	2.96

### 5.7 Landing Distance

**Associated conditions:**

Weight	600 kg / 1323 lb
CG (22.0 %MAC)	Most FWD at MTOW
Flaps	<b>FLAPS 2 (24°)</b>
Engine power	IDLE
Procedure	Normal landing
Wind	Zero
Runaway slope	Zero
Braking	During ground roll

**Example:**

Pressure altitude	2000
Outside air temperature	15 °C
Runway	Paved (dry asphalt)
Tailwind	2 knots

Distance over 50 ft (15 m) obstacle	1729 ft / 527 m
Landing ground roll	514 ft / 156 m

**NOTE**

Poor maintenance condition of the aircraft, deviation from the given procedures as well as unfavourable outside conditions (rain, unfavourable wind conditions, including crosswind) could increase the landing distance considerably.

RWY surface:			PAVED (dry asphalt)				NON - PAVED (dry grass)			
ISA conditions			Landing distance over 50 ft (15 m)		Ground roll (braked)		Landing distance over 50 ft (15 m)		Ground roll (braked)	
Pressure altitude	Δ OAT ISA	OAT								
ft	°C	°C	ft	m	ft	m	ft	m	ft	m
<b>SL</b>	-30	-15	1090	332	324	99	1380	421	606	185
	-20	-5	1176	359	349	107	1489	454	654	199
	-10	5	1266	386	376	115	1602	488	703	214
	<b>0</b>	<b>15</b>	<b>1358</b>	<b>414</b>	<b>404</b>	<b>123</b>	<b>1719</b>	<b>524</b>	<b>755</b>	<b>230</b>
	10	25	1454	443	432	132	1841	561	808	246
	20	35	1553	473	462	141	1966	599	863	263
	30	45	1656	505	492	150	2096	639	920	280
<b>2000</b>	-30	-19	1223	373	363	111	1547	472	679	207
	-20	-9	1321	403	392	120	1672	509	734	224
	-10	1	1423	434	423	129	1801	549	790	241
	<b>0</b>	<b>11</b>	<b>1528</b>	<b>466</b>	<b>454</b>	<b>138</b>	<b>1934</b>	<b>590</b>	<b>849</b>	<b>259</b>
	10	21	1638	499	487	148	2073	632	910	277
	20	31	1751	534	520	159	2216	675	973	296
	30	41	1868	569	555	169	2364	721	1038	316

**Influence of wind:** - Add 5% to table distances for each 1 knots tailwind up to 10 knots.

# WT9 Dynamic LSA / Club

Pilot's Operating Handbook



AS-POH-01-000

RWY surface:			PAVED (dry asphalt)				NON - PAVED (dry grass)			
ISA conditions			Landing distance over 50 ft (15 m)		Ground roll (braked)		Landing distance over 50 ft (15 m)		Ground roll (braked)	
Pressure altitude	Δ OAT ISA	OAT								
ft	°C	°C	ft	m	ft	m	ft	m	ft	m
<b>4000</b>	-30	-23	1374	419	408	124	1738	530	763	233
	-20	-13	1485	453	441	135	1880	573	825	252
	-10	-3	1602	488	476	145	2027	618	890	271
	<b>0</b>	<b>7</b>	<b>1723</b>	<b>525</b>	<b>512</b>	<b>156</b>	<b>2180</b>	<b>665</b>	<b>957</b>	<b>292</b>
	10	17	1848	563	549	167	2339	713	1026	313
	20	27	1977	603	587	179	2503	763	1098	335
	30	37	2111	643	627	191	2672	814	1173	357
<b>6000</b>	-30	-27	1545	471	459	140	1955	596	858	262
	-20	-17	1673	510	497	151	2117	645	929	283
	-10	-7	1806	550	537	164	2286	697	1003	306
	<b>0</b>	<b>3</b>	<b>1944</b>	<b>593</b>	<b>578</b>	<b>176</b>	<b>2461</b>	<b>750</b>	<b>1080</b>	<b>329</b>
	10	13	2087	636	620	189	2642	805	1160	353
	20	23	2236	681	664	202	2830	862	1242	379
	30	33	2389	728	710	216	3024	922	1327	405
<b>8000</b>	-30	-31	1740	530	517	158	2202	671	967	295
	-20	-21	1886	575	560	171	2388	728	1048	319
	-10	-11	2039	621	606	185	2581	787	1133	345
	<b>0</b>	<b>-1</b>	<b>2197</b>	<b>670</b>	<b>653</b>	<b>199</b>	<b>2781</b>	<b>848</b>	<b>1221</b>	<b>372</b>
	10	9	2362	720	702	214	2989	911	1312	400
	20	19	2532	772	752	229	3204	977	1407	429
	30	29	2708	825	805	245	3427	1045	1504	459
<b>10000</b>	-30	-35	1964	599	584	178	2486	758	1091	333
	-20	-25	2132	650	634	193	2699	823	1185	361
	-10	-15	2308	703	686	209	2921	890	1282	391
	<b>0</b>	<b>-5</b>	<b>2490</b>	<b>759</b>	<b>740</b>	<b>225</b>	<b>3151</b>	<b>960</b>	<b>1383</b>	<b>422</b>
	10	5	2679	816	796	243	3390	1033	1488	454
	20	15	2875	876	854	260	3638	1109	1597	487
	30	25	3077	938	914	279	3895	1187	1710	521

**Influence of wind:** - Add 5% to table distances for each 1 knots tailwind up to 10 knots.

### 5.8 Demonstrated Crosswind Performance

**Associated conditions:**

Runway heading	15°
Wind direction	75°
Wind velocity	6.0 m/s (11.7 knots)

**Example:**

Wind / Flight path angle	60°
Crosswind component	5.2 m/s (10.1 knots)
Headwind component	3.0 m/s (5.8 knots)

The maximum demonstrated crosswind speed for takeoff was 8.3 m/s (16.1 knots) and for landing was 7.5 m/s (14.6 knots).

The maximum demonstrated crosswind values are not considered limiting.

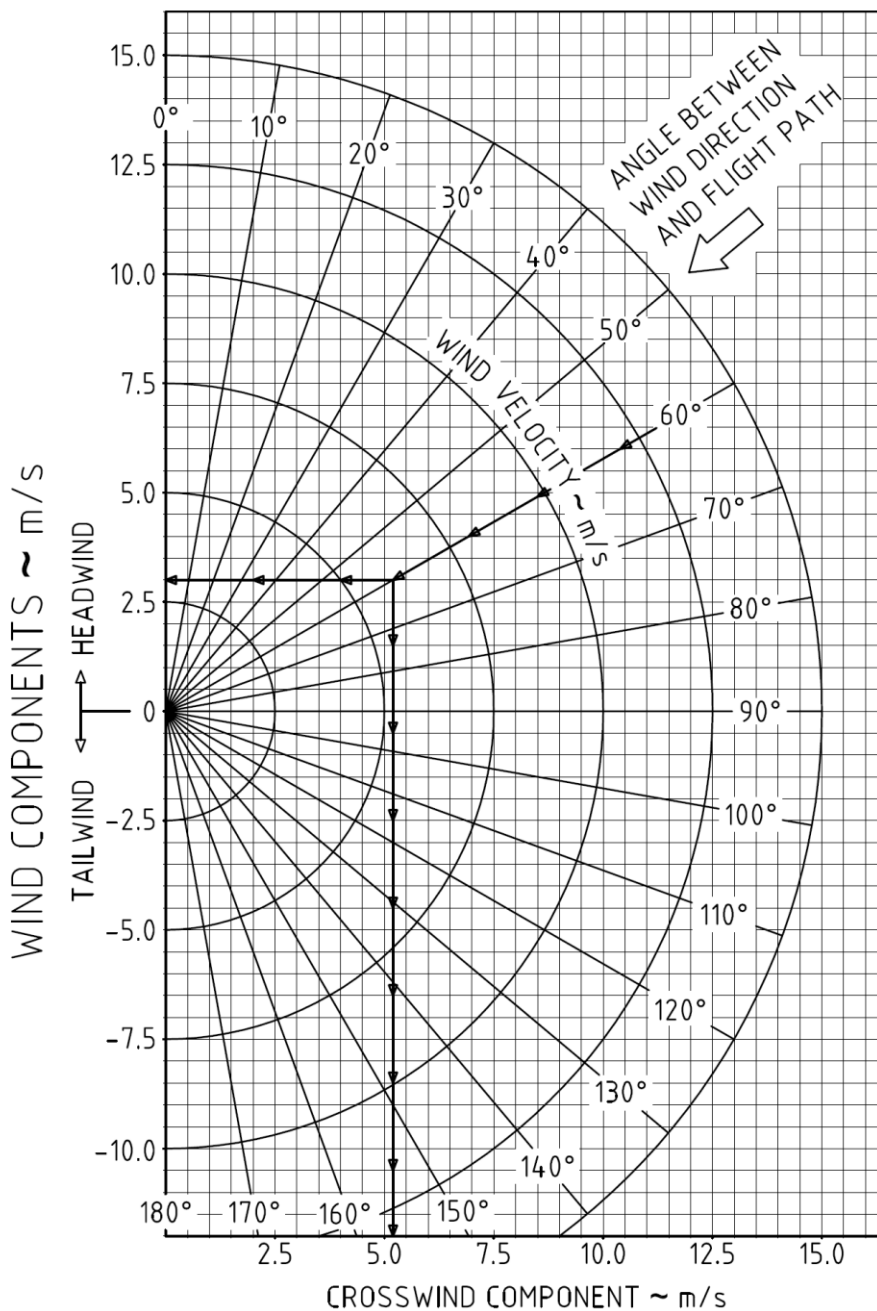

Fig. 5-1 Crosswind - Metric Units

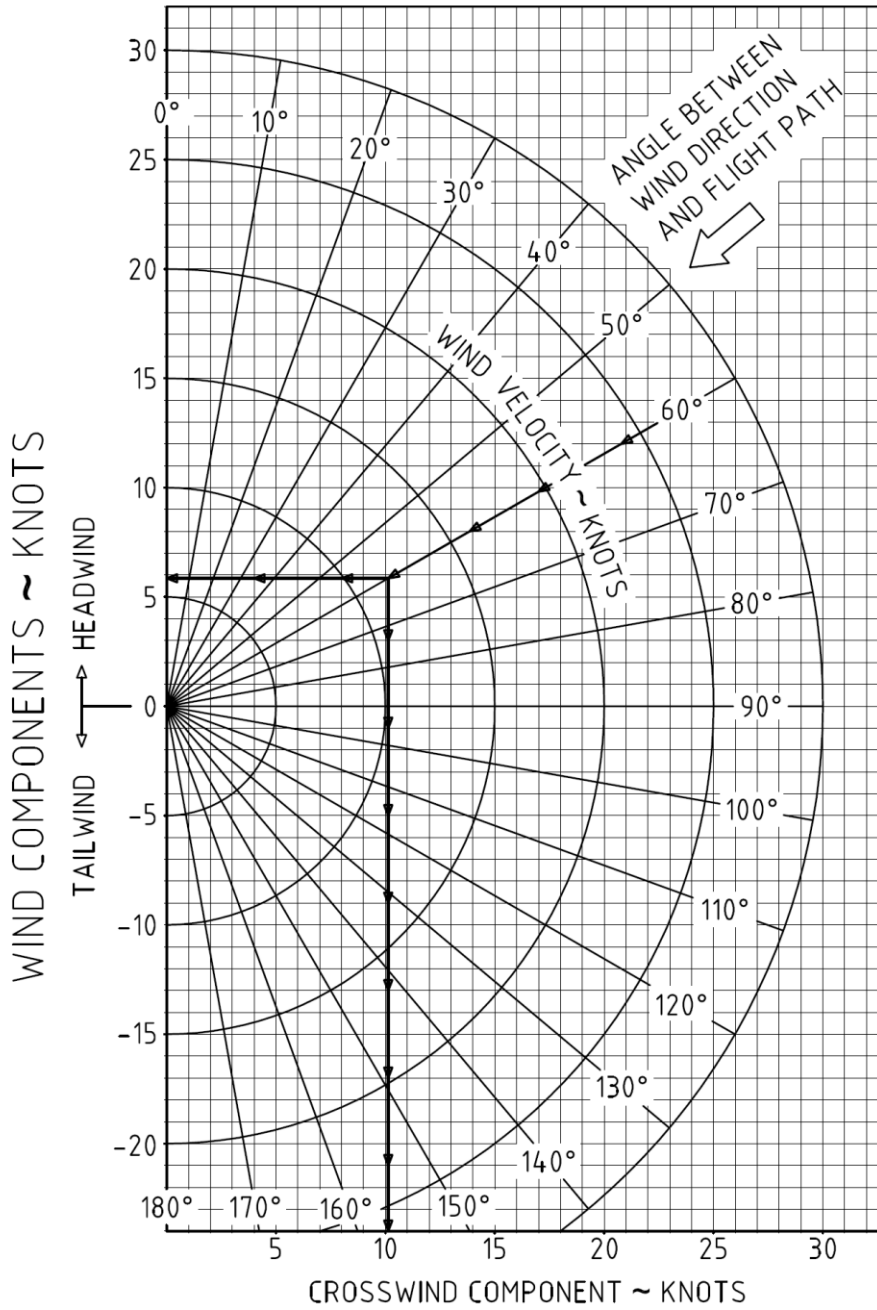

Fig. 5-2 Crosswind - U. S. Standard Units

This page is left blank intentionally

# 6 WEIGHT AND BALANCE, AND EQUIPMENT LIST

## TABLE OF CONTENTS

<b>6.1</b>	<b>GENERAL .....</b>	<b>6-2</b>
<b>6.2</b>	<b>AIRCRAFT WEIGHING PROCEDURE .....</b>	<b>6-3</b>
6.2.1	Calculation Method.....	6-3
6.2.2	Weighing Method .....	6-4
6.2.3	Aircraft Weighing Form.....	6-6
<b>6.3</b>	<b>WEIGHT AND BALANCE RECORD .....</b>	<b>6-7</b>
<b>6.4</b>	<b>WEIGHT AND BALANCE DETERMINATION FOR FLIGHT.....</b>	<b>6-8</b>
6.4.1	Aircraft Weight and CG Limits.....	6-8
6.4.2	Weight and Balance Loading Form .....	6-11
6.4.3	Example of Calculation.....	6-13
<b>6.5</b>	<b>LOADING DATA.....</b>	<b>6-14</b>
6.5.1	Weights and Moments of Variable Masses – Metric Units .....	6-14
6.5.2	Weights and Moments of Variable Masses – U. S. Standard Units.....	6-16
6.5.3	Fuel Quantity and Weight Conversion Chart – Metric Units .....	6-18
6.5.4	Fuel Quantity and Weight Conversion Chart – U. S. Standard Units.....	6-19
<b>6.6</b>	<b>WEIGHT AND MOMENT LIMITS CHART.....</b>	<b>6-20</b>
6.6.1	Metric Units.....	6-20
6.6.2	U. S. Standard Units .....	6-21
<b>6.7</b>	<b>EQUIPMENT LIST.....</b>	<b>6-22</b>

### 6.1 General

This Chapter contains weight and balance records and the loading range for safe operation of WT9 Dynamic LSA aircraft. As a pre-requisite for safe flight the pilot in command must ensure that the loaded and fueled aircraft's weight and moment are within approved limits during takeoff, flight and landing.

The Basic Empty Weight / Moment are initially specified by the aircraft's manufacturer and are recorded into the Weight and Balance Record (Chapter 6.3). Installation or removal of any equipment will influence this initial data. It is the duty of any authorized organization installing (or removing) any equipment on (or from) the aircraft to determine the resulting new Basic Empty Weight / Moment for the aircraft.

The Weight and Balance Record must be maintained current and up-to-date. In simple cases the new Basic Empty Weight / Moment may be calculated. In more complex cases the new Basic Empty Weight / Moment must be determined by weighing the newly configured aircraft. The new Basic Empty Weight / Moment values shall be recorded immediately, along with all other pertinent information into the aircraft's Weight and Balance Record (Chapter 6.3). The updated Weight and Balance Record must be used when calculating loading plans for all future flights.

The WT9 Dynamic LSA center of gravity is expressed as a moment. The moment represents the sum of each individual load's moment. Each individual load's moment is the multiple of its applied load and its distance from a Reference Datum. The distance from the Reference Datum to the point of each load's application is known as the CG Arm. The Reference Datum is located 1.975 m / 77.76 in forward from inner surface of the firewall. The inner surface of the firewall is identical with the engine cowlings and fuselage vertical border line in which the reference point (RP) lies (see Chapter 6.2.3).

The approved Aircraft Weight and Moment Limit are presented graphically in the Weight and Moment Limits Chart (see Chapter 6.6). The limitations presented in the Weight and Moment Limits Chart must be adhered to. If the aircraft is improperly loaded or overloaded with co-pilot (passenger), baggage or fuel the aircraft's performance, structural strength and center of gravity may be dangerously influenced. If the center of gravity is too far forward it may be difficult, or impossible, to rotate for takeoff and to flare for landing. If the center of gravity is too far aft longitudinal stability and aircraft controllability may be dangerously influenced.

#### **WARNING**

The loaded aircraft must be operated within approved weight and CG limits during takeoff, flight and landing!

#### **NOTE**

Prior to fueling the aircraft, check the flight's loading plan and determine the permissible quantity of fuel. If the loaded and fueled aircraft is out of weight and CG limitations, the aircraft must be reloaded.

The total weight and cumulative moment of a loaded and fuelled aircraft is simply calculated using the Weight and Balance Loading Form (Chapter 6.4.2). This calculation requires the aircraft's Basic Empty Weight / Moment, the weight of pilot/co-pilot (passenger), the total weight of baggage in the front and rear baggage compartments, and the usable weight of fuel. The aircraft's Basic Empty Weight / Moment are obtained from the aircraft's Weight and Balance Record (Chapter 6.3).



## 6.2 Aircraft Weighing Procedure

### 6.2.1 Calculation Method

When a compact piece of equipment is installed on (or removed from) the aircraft and an accurate weight and center of gravity arm (distance from the aircraft's Reference Datum to the installed equipment's center of gravity) can be accurately specified, the newly configured aircraft's Basic Empty Weight / Moment can be calculated using the aircraft's Weight and Balance Record (Chapter 6.3).

#### CAUTION

When calculating a new Basic Empty Weight / Moment pay close attention to ensure consistent usage of measuring units (U. S. Standard or Metric).

1. Record the date the item was installed on (or removed from) to the aircraft in the "Date" column.
2. Mark an "X" into the "Item No. In" column if the equipment was installed.
3. Mark an "X" into the "Item No. Out" column if the equipment was removed.
4. Record a brief description of the item or modification into the "Description of Article or Modification" column.
5. Record the item's weight into the "Weight Change" column's "Weight" column:
  - a) "Added (+)" column for installed items.
  - b) "Removed (-)" column for removed items.
6. Record the item's CG arm into the "Weight Change" column's "Arm" column:
  - a) "Added (+)" column for installed items.
  - b) "Removed (-)" column for removed items.
7. Calculate the moment by multiplying the item's weight and arm together and enter the resulting value into the "Weight Change" column's "Moment" column:
  - a) "Added (+)" column for installed items.
  - b) "Removed (-)" column for removed items.
8. Calculate the aircraft's new Basic Empty Weight and enter the value into the "Basic Empty – Weight" column:
  - a) For added items, calculate the aircraft's new Basic Empty Weight by adding the item's weight to the aircraft's previous Basic Empty Weight.
  - b) For removed items, calculate the aircraft's new Basic Empty Weight by subtracting the item's weight from the aircraft's previous Basic Empty Weight.
9. Calculate the aircraft's new Basic Empty Moment and enter the value into the "Basic Empty – Moment" column:
  - a) For added items, calculate the aircraft's new Basic Empty Moment by adding the item's moment to the aircraft's previous Basic Empty Moment.
  - b) For removed items, calculate the aircraft's new Basic Empty Moment by subtracting the item's moment from the aircraft's previous Basic Empty Moment.

### 6.2.2 Weighing Method

When complex modifications, accomplishment of service bulletins, removing/installation of equipment or loss of records have occurred, the new Basic Empty Weight / Moment must be determined by weighing the aircraft. The new values must be recorded into the aircraft's Weight and Balance Record (Chapter 6.3).

1. Aircraft preparation for weighing:
  - a) Defuel the aircraft's fuel system (see 8.3.2).
  - b) Weigh the aircraft in a closed building to prevent errors due to wind gusts.
  - c) Remove all snow, ice, dirt and water from the aircraft's surfaces.
  - d) Remove all snow, ice and dirt from the wheel fairings.
  - e) Remove all objects not included in the aircraft's Approved Equipment List.
  - f) Remove all objects not included in the aircraft's Weight and Balance Record.
  - g) Verify all items in the Equipment List are installed in their correct location.
  - h) Inflate the aircraft's tires to their recommended operating pressures.
  - i) Verify oil, brake fluid and coolant are at their prescribed maximum levels.
  - j) Close covers and other lids.
  - k) Place scales under each wheel (minimum scale capacity 300 kg / 660 lb).
  - l) Brake lever to PARK position.
  - m) Remove the external control locks and place all controls to their neutral position. Retract the wing flaps.
2. Aircraft leveling:
  - a) Level laterally with a bubble-level placed across the cabin sills above the main spar with the canopy opened (Fig. 6-1). If the bubble-level is not long enough, a suitable extension (e.g. even wooden plank) may be used with the bubble-level placed on top. Be careful not to damage the cabin sills when leveling.
  - b) Remove bubble-level and close the canopy.
  - c) Level longitudinally with a bubble-level placed on the canopy frame (Fig. 6-1). Adjust the level by deflating the nose wheel's tire or install suitable pads under the nose/main wheel scales.

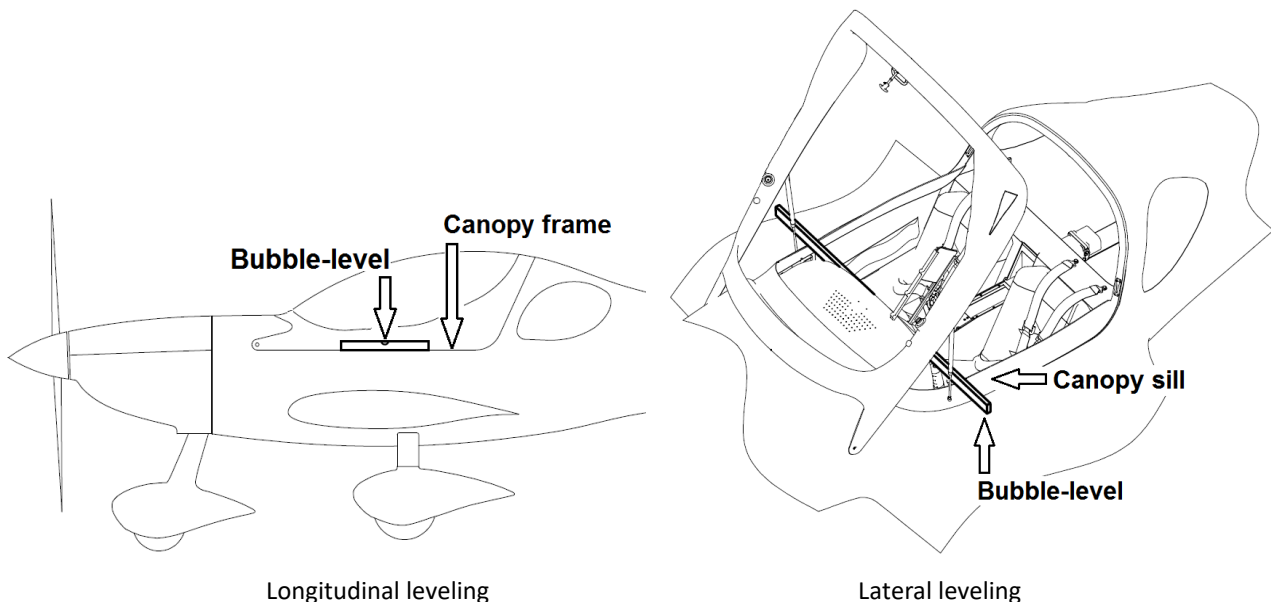

Fig. 6-1 Aircraft leveling

## 3. Weighing (see Chapter 6.2.3):

- a) With the aircraft leveled and canopy closed, obtain and record the aircraft data into a photocopy of the Aircraft Weighing Form (Chapter 6.2.3).
- b) Obtain and record the value "X" by measuring horizontally and parallel to the aircraft center line, from a line stretched between main wheel centers to a plumb line dropped from the Reference Point (RP).
- c) Obtain and record the value "Y" by measuring horizontally and parallel to the aircraft center line, from a line stretched between main wheel centers to a plumb line dropped from the center of nose wheel axle.
- d) Obtain and record the weights shown on each scale, deduct the tare (if any) and calculate the net weights.
- e) Determine and record the arms "A" and "B".
- f) Determine and record the moment for each weighting point using following formula:

$$\text{Moment} = \text{Net weight} \times \text{Arm}$$

- g) Calculate and record the Empty Weight / Moment by totaling the appropriate columns. Calculate and record the Empty Weight CG using formula given in the form.
  - h) Calculate the correction for unusable fuel and record the Basic Empty Weight / Moment. Calculate and record the Basic Empty Weight CG using formula given in the form.
  - i) Compare the calculated values with the permitted limits given in the Chapter 6.4.1.
  - j) Record the new Basic Empty Weight / Moment in the Weight and Balance Record (Chapter 6.3).
4. After weighing:
- a) Ensure all air is removed from the fuel system.
  - b) Inflate the nose and main landing gear tires to their prescribed operating pressures.

**CAUTION**

Remove all items, which are not a part of the aircraft equipment (including bubble-level) and close the canopy before weighing!

**CAUTION**

When calculating a new Basic Empty Weight / Moment pay close attention to ensure consistent usage of measuring units (U. S. Standard or Metric).

**NOTE**

If the deflation of the nose wheel's tire is not sufficient, install suitable pads under the nose/main wheel scales.

### 6.2.3 Aircraft Weighing Form

<b>Type:</b>	<b>Model:</b>	<b>Serial Number:</b>	<b>Reg. Number:</b>	<b>Date:</b>
WT9 Dynamic LSA	Club			

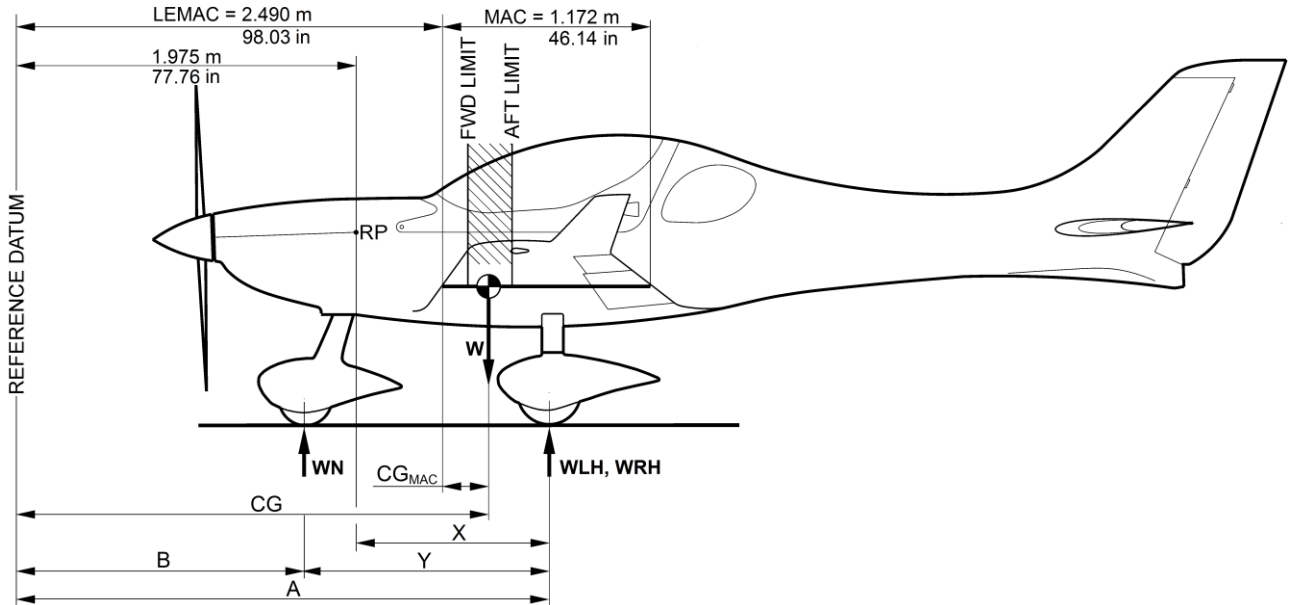

<b>Measured:</b> X = ..... m (in) Y = ..... m (in)	<b>Calculated:</b> A = X + 1.975 m (77.76 in) B = A - Y
--	---

AIRCRAFT EMPTY WEIGHT / MOMENT AND CG AS WEIGHED (Including operating fluids without unusable fuel)					
Weighing point	Scale reading (kg / lb)	- Tare (kg / lb)	= Net weight (kg / lb)	x Arm (m / in)	= Moment (kg.m / lb.in/100)
Main LH				A =	
Main RH				A =	
Nose				B =	
Empty Weight / Moment				CG =	
$CG = \frac{\text{Total Moment}}{\text{Total Weight}}$					

BASIC EMPTY WEIGHT / MOMENT AND CG (Including operating fluids with unusable fuel)			
<b>Unusable fuel</b> (Add to empty aircraft weight and moment)	5.0 kg / 11 lb	2.580 m / 101.57 in	12.90 kg.m / 11.17 lb.in/100
Basic Empty Weight / Moment		CG =	



### 6.4 Weight and Balance Determination for Flight

This part describes the procedure for calculating the weight and moment for various phases of a planned flight and ensuring the center of gravity is within approved limits. To calculate the weight and moment of a loaded aircraft use a Weight and Balance Loading Form (Chapter 6.4.2).

#### 6.4.1 Aircraft Weight and CG Limits

The charts on Fig. 6-2 (Metric Units) and Fig. 6-3 (U. S. Standard Units) depict the aircraft's operational CG envelope in the terms of CG arm aft of reference datum and as a percentage of the MAC. The relationship between CG arm and percentage of the MAC is detailed in the Chapter 6.2.3.

	Metric Units	U. S. Standard Units
Empty Weight	Max. 410.8 kg	Max. 906 lb
Empty CG range	12.5 to 13.5 %MAC 2.637 to 2.648 m (aft of Datum)	12.5 to 13.5 %MAC 103.80 to 104.26 in (aft of Datum)
Basic Empty CG range	12.4 to 13.4 %MAC 2.636 to 2.647 m (aft of Datum)	12.4 to 13.4 %MAC 103.77 to 104.22 in (aft of Datum)
Forward CG (operating limit)	2.704 m (18.3 %MAC) at 542.5 kg with straight line taper to 2.748 m (22.0 %MAC) at 600.0 kg	106.48 in (18.3 %MAC) at 1196 lb with straight line taper to 108.18 in (22.0 %MAC) at 1323 lb
Rearward CG (operating limit)	2.824 m (28.5 %MAC) at 600.0 kg	111.18 in (28.5 %MAC) at 1323 lb

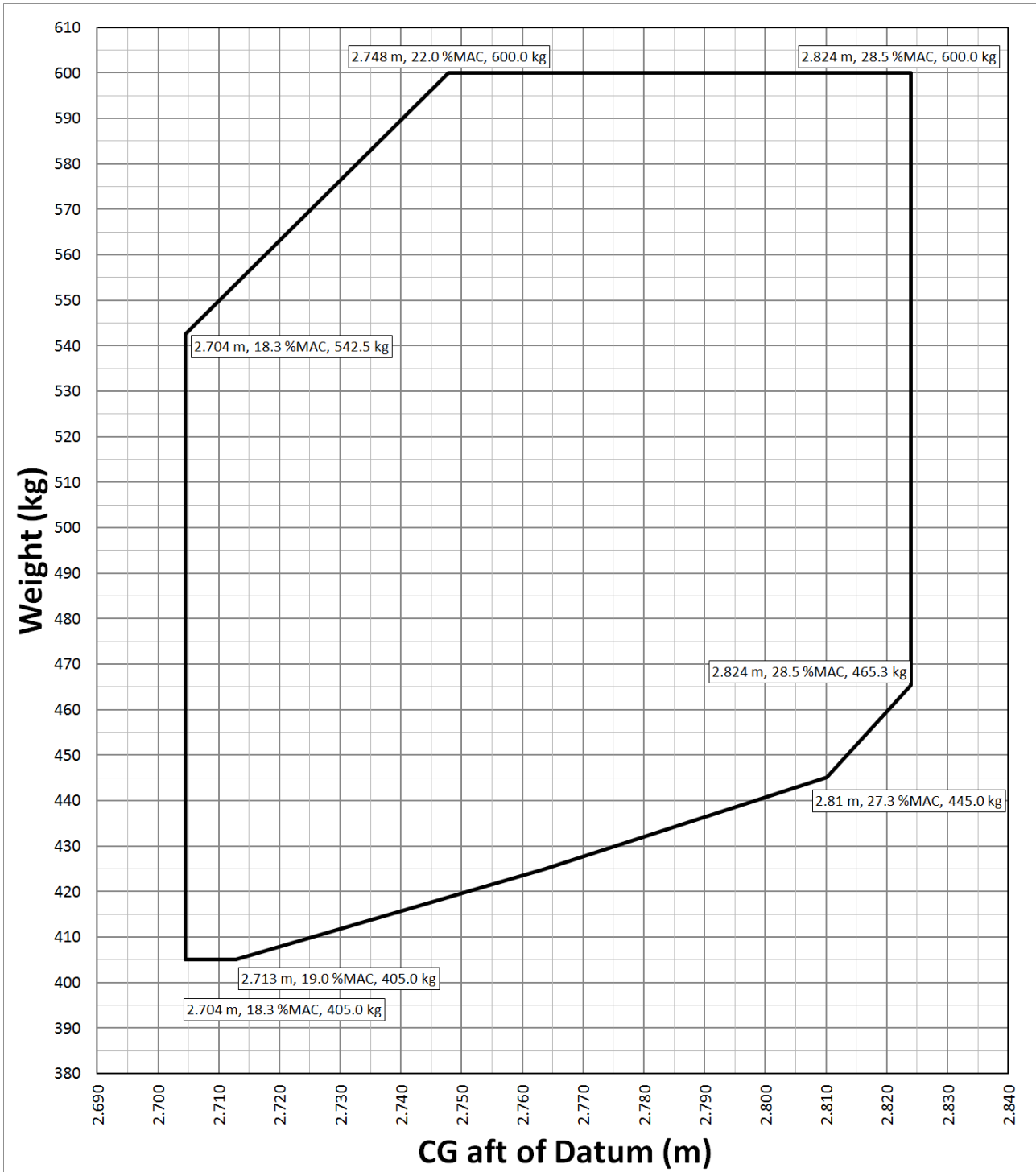

Fig. 6-2 Operating Weight /CG limit – Metric Units

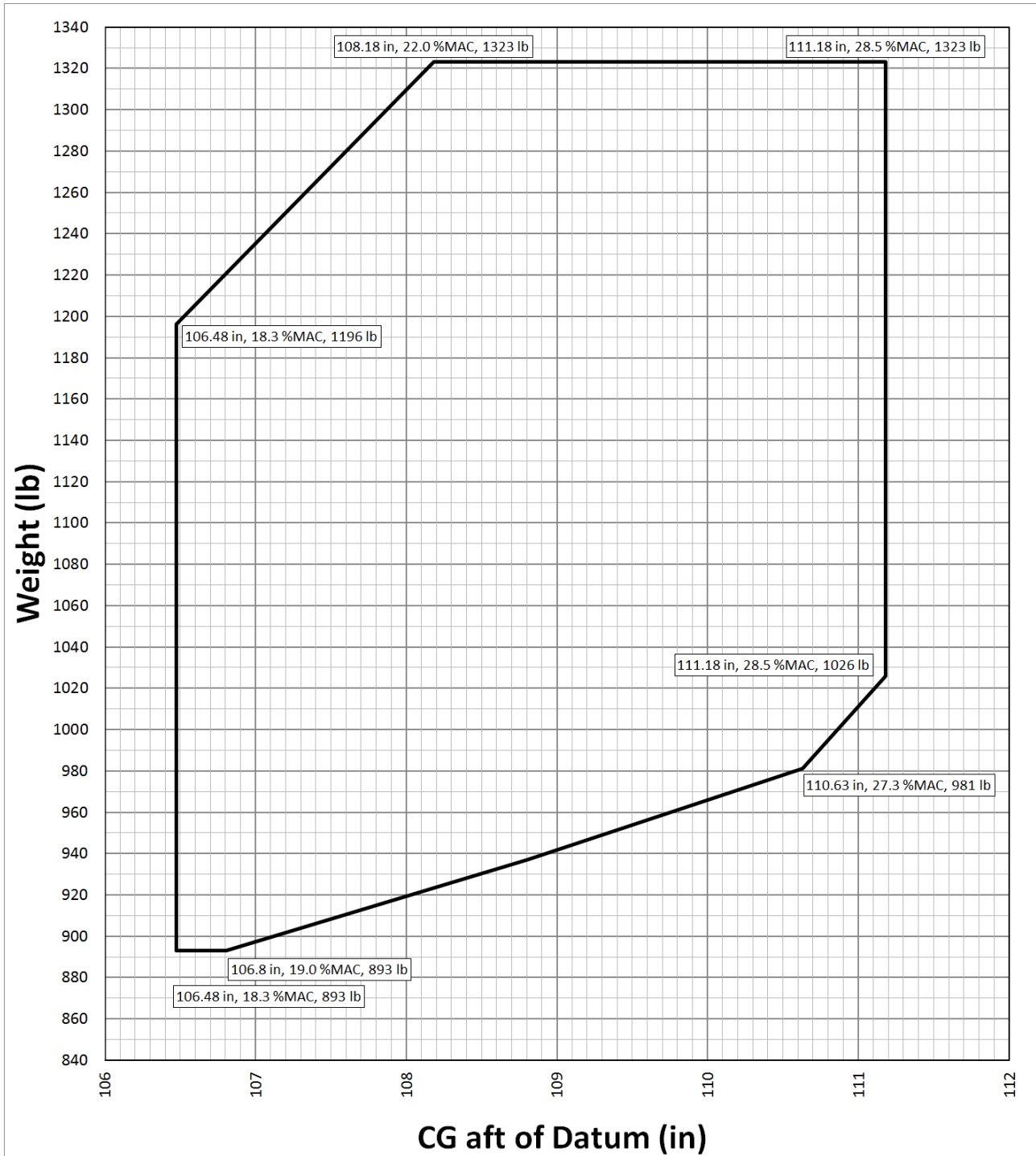

Fig. 6-3 Operating Weight /CG limit – U. S. Standard Units



### 6.4.2 Weight and Balance Loading Form

It is the responsibility of the pilot in command to ensure that the aircraft will be properly loaded within the weight and moment limits during takeoff, flight and landing. The weight and balance loading form enables the pilot to determine the aircraft loading using Loading Data (6.5) and to compare with the limits given in Weight and Moment Limits Chart (6.6).

The example is shown in the table below and on Fig. 6-4. For blank Weight and Moment Limits Chart refer to Chapter 6.6.

<b>Weight and Balance Loading Form</b>							
<b>Aircraft:</b> WT9 Dynamic LSA / Club		<b>Serial Number:</b>		<b>Reg. Number:</b>		<b>Date:</b>	
No.	Item	Example aircraft		Your aircraft			
		Weight	Moment	Weight	Moment		
		kg / <del>lb</del>	kg.m / <del>lb.in/100</del>	kg / lb	kg.m / lb.in/100		
1.	<b>Basic Empty Weight / Moment</b> (See Chapter 6.3) (Including unusable fuel)	<b>350.0</b>	<b>922.90</b>				
2.	Pilot (Min. 55 kg / 121 lb, Max. 120 kg / 265 lb)	90.0	281.70				
3.	Co-pilot (passenger) (Max. 120 kg / 265 lb)	81.0	253.53				
4.	Front baggage compartment (Max. 2 x 10 kg / 2 x 22 lb)	6.0	15.48				
5.	Rear baggage compartment (Max. 2 x 20 kg / 2 x 44 lb)	10.0	37.95				
6.	Usable fuel (max. 85.7 kg / 189 lb)	57.6	148.61				
7.	<b>Takeoff Weight / Moment</b> (Sum of lines No. 1 through 6)	<b>594.6</b>	<b>1660.17</b>				
8.	<b>Zero Fuel Weight / Moment</b> (Sum of lines No. 1 through 5)	<b>537.0</b>	<b>1511.56</b>				

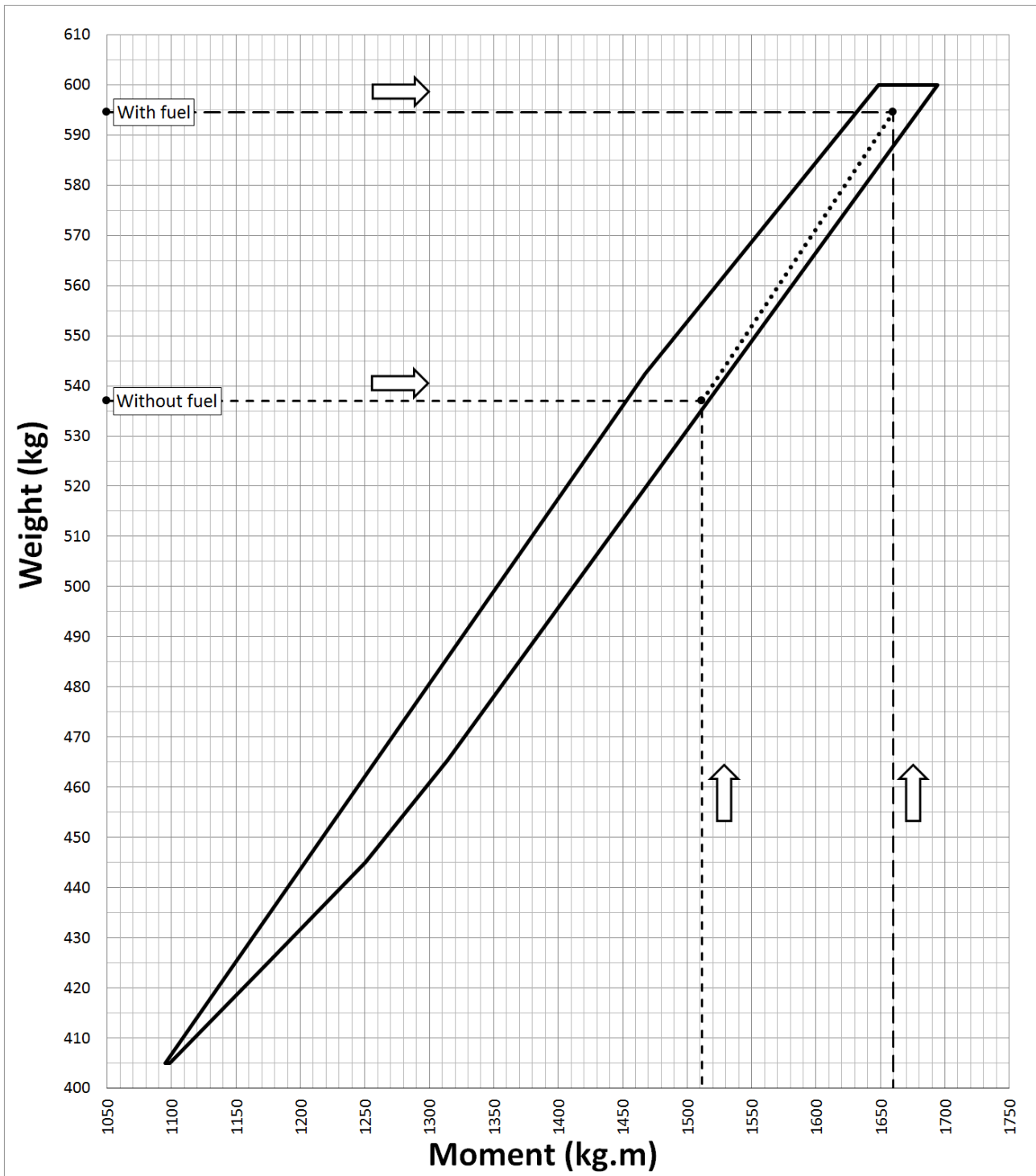

Fig. 6-4 Check of flight weight/moment limits – Example (Metric Units)

### 6.4.3 Example of Calculation

#### TASK:

Determine the aircraft takeoff weight and moment for the following flight conditions:

- Aircraft basic empty weight 350.0 kg
- Aircraft basic empty moment 922.90 kg.m
- Pilot 90.0 kg
- Co-pilot (passenger) 81.0 kg
- Front baggage 6.0 kg
- Rear baggage 10.0 kg
- Fuel in tanks 57.6 kg (80 l)

#### CALCULATION:

#### NOTE

Calculations of the loaded aircraft's weight and moment example are made in the metric system.

1. Obtain and record the aircraft data into a photocopy of the Weight and Balance Loading Form (Chapter 6.4.2).
2. Obtain and record the Basic Empty Weight and Moment of the aircraft in line No. 1, from the Weight and Balance Record (Chapter 6.3). For the purpose of example, the values given in the task have been used.
3. Obtain and record the pilot, co-pilot (passenger), front baggage, rear baggage, usable fuel weights and moments using the loading data (Chapter 6.5) and record them appropriately in lines No. 2 through 6.
4. Adding the weights in lines No. 1 through 6 **the takeoff weight** (line No. 7) is obtained (this must be lower than the weight limits given in Chapter 2.4. Adding the static moments in lines No. 1 through 6 the resulting static **takeoff moment** (line No. 7) is obtained.
5. Adding the weights in lines No. 1 through 5 **the zero fuel weight** (line No. 8) is obtained. Adding the static moments in lines No. 1 through 5 the resulting static **zero fuel moment** (line No. 8) is obtained.
6. Plot the takeoff weight and moment from line No. 7 and the zero fuel weight and moment from line No. 8 into the appropriate Weight and Moment Limits Chart (Chapter 6.6). The intersection of both values must be within the represented approved limits envelope.

The example is shown on Fig. 6-4. The aircraft's Center of Gravity Arm is calculated by dividing the aircraft's moment by the aircraft's weight.

#### CONCLUSION

The intersection of the takeoff weight and moment and zero fuel weight and moment are within the approved limits of the Weight and Moment Limits Chart (see Fig. 6-4). **From the point of view of the aircraft weight and CG, the flight can be realized.**

#### WARNING

Takeoff weight and CG must be calculated before each flight!  
Fuel consumption moves the CG rearwards, therefore the CG must be calculated for zero fuel as well!

### 6.5 Loading Data

#### 6.5.1 Weights and Moments of Variable Masses – Metric Units

Weight	Moment			
	Pilot / co-pilot (passenger) (Arm 3.130 m)	Front baggage (Arm 2.580 m)	Rear baggage (Arm 3.795 m)	Fuel (Arm 2.580 m)
kg	kg.m	kg.m	kg.m	kg.m
2		5.16	7.59	5.16
4		10.32	15.18	10.32
6		15.48	22.77	15.48
8		20.64	30.36	20.64
10		25.80	37.95	25.80
12		30.96	45.54	30.96
14		36.12	53.13	36.12
16		41.28	60.72	41.28
18		46.44	68.31	46.44
20		51.60	75.90	51.60
25			94.88	64.50
30			113.85	77.40
35			132.83	90.30
40			151.80	103.20
45				116.10
50				129.00
55	172.15			141.90
60	187.80			154.80
65	203.45			167.70
70	219.10			180.60
75	234.75			193.50
80	250.40			206.40
85	266.05			219.30
90	281.70			232.20
95	297.35			
100	313.00			
105	328.65			
110	344.30			
115	359.95			
120	375.60			

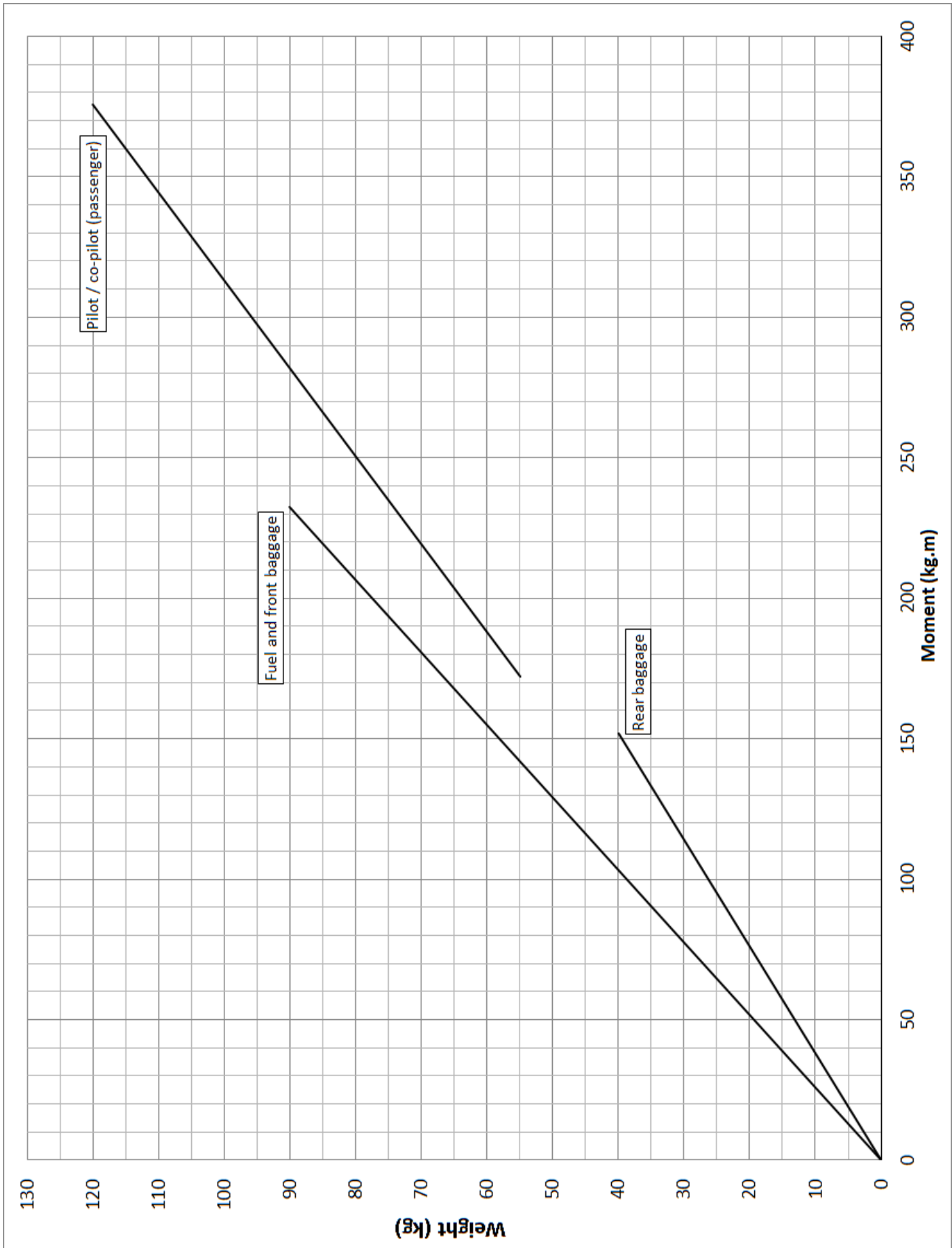

Fig. 6-5 Weights and moments of variable masses chart – Metric Units

### 6.5.2 Weights and Moments of Variable Masses – U. S. Standard Units

Weight	Moment			
	Occupants (Arm 123.23 in)	Front baggage (Arm 101.57 in)	Rear baggage (Arm 149.41 in)	Fuel (Arm 101.57 in)
lb	lb.in/100	lb.in/100	lb.in/100	lb.in/100
5		5.08	7.47	5.08
10		10.16	14.94	10.16
15		15.24	22.41	15.24
20		20.31	29.88	20.31
25		25.39	37.35	25.39
30		30.47	44.82	30.47
35		35.55	52.29	35.55
40		40.63	59.76	40.63
45		45.71	67.23	45.71
50			74.70	50.79
60			89.65	60.94
70			104.59	71.10
80			119.53	81.26
90			134.47	91.42
100				101.57
110				111.73
120	147.87			121.89
130	160.20			132.05
140	172.52			142.20
150	184.84			152.36
160	197.16			162.52
170	209.49			172.68
180	221.81			182.83
190	234.13			192.99
200	246.46			203.15
210	258.78			
220	271.10			
230	283.42			
240	295.75			
250	308.07			
260	320.39			
270	332.72			

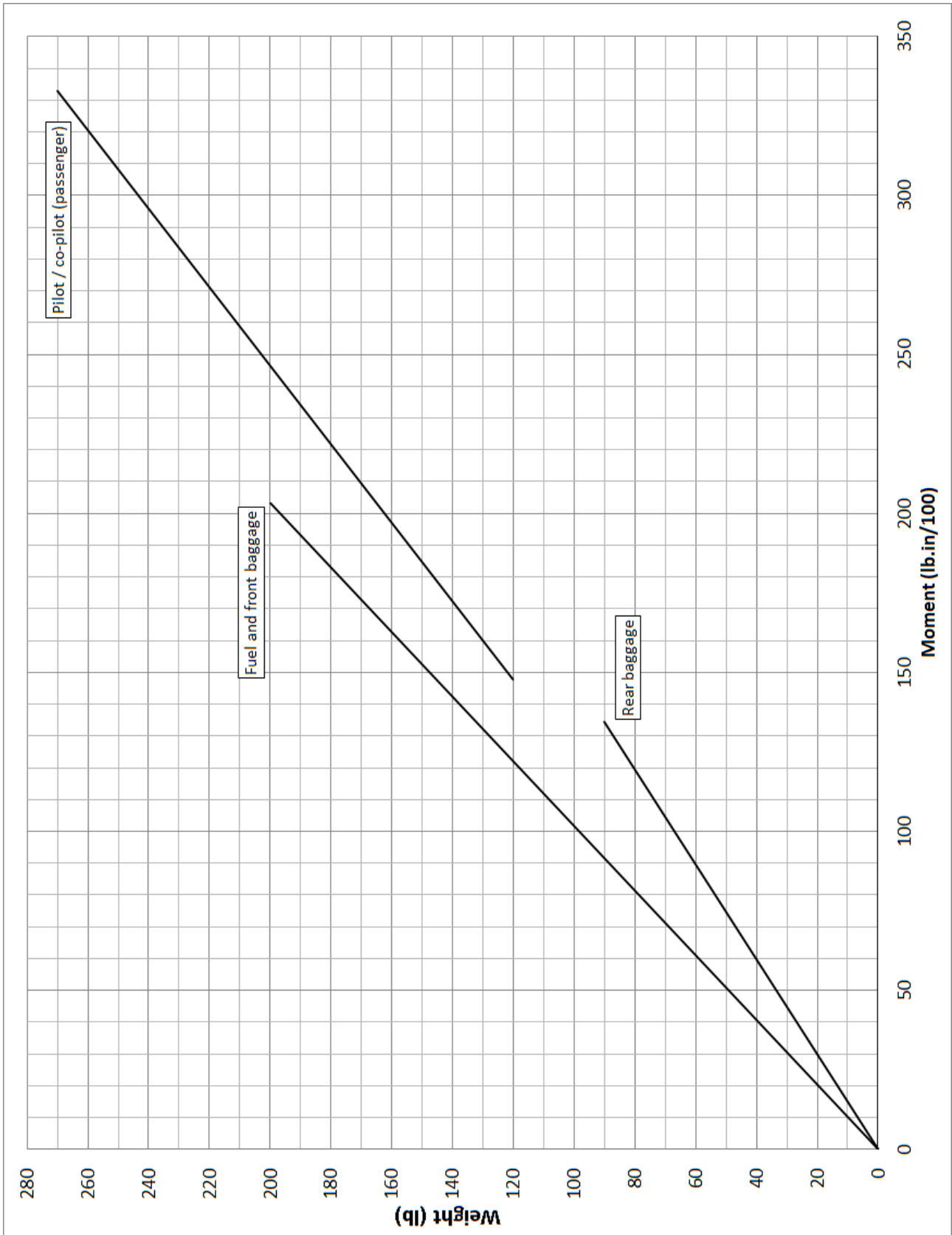

Fig. 6-6 Weights and moments of variable masses chart – U. S. Standard Units

**6.5.3 Fuel Quantity and Weight Conversion Chart – Metric Units**

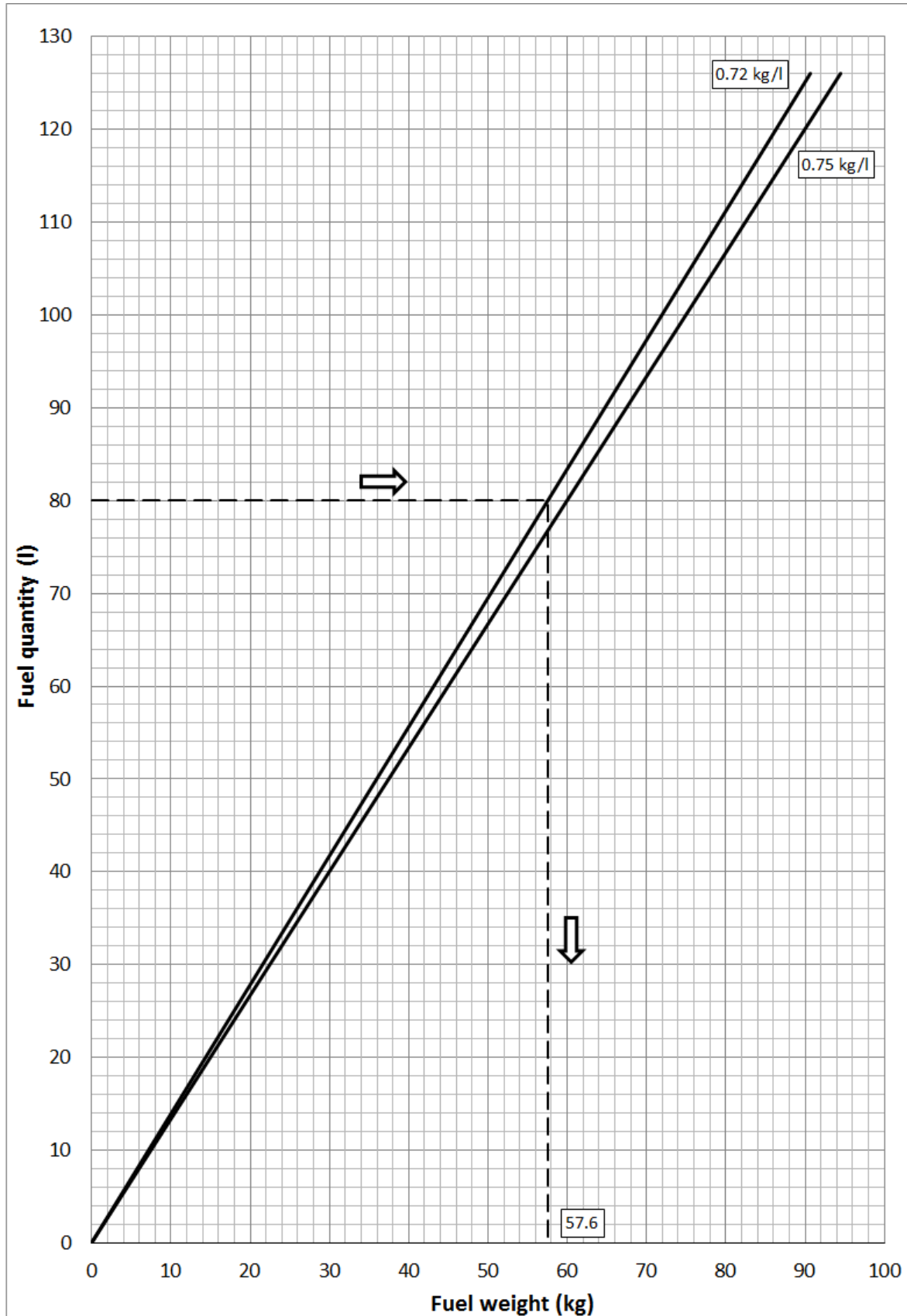

Fig. 6-7 Fuel quantity and weight conversion chart – Metric Units



6.5.4 Fuel Quantity and Weight Conversion Chart – U. S. Standard Units

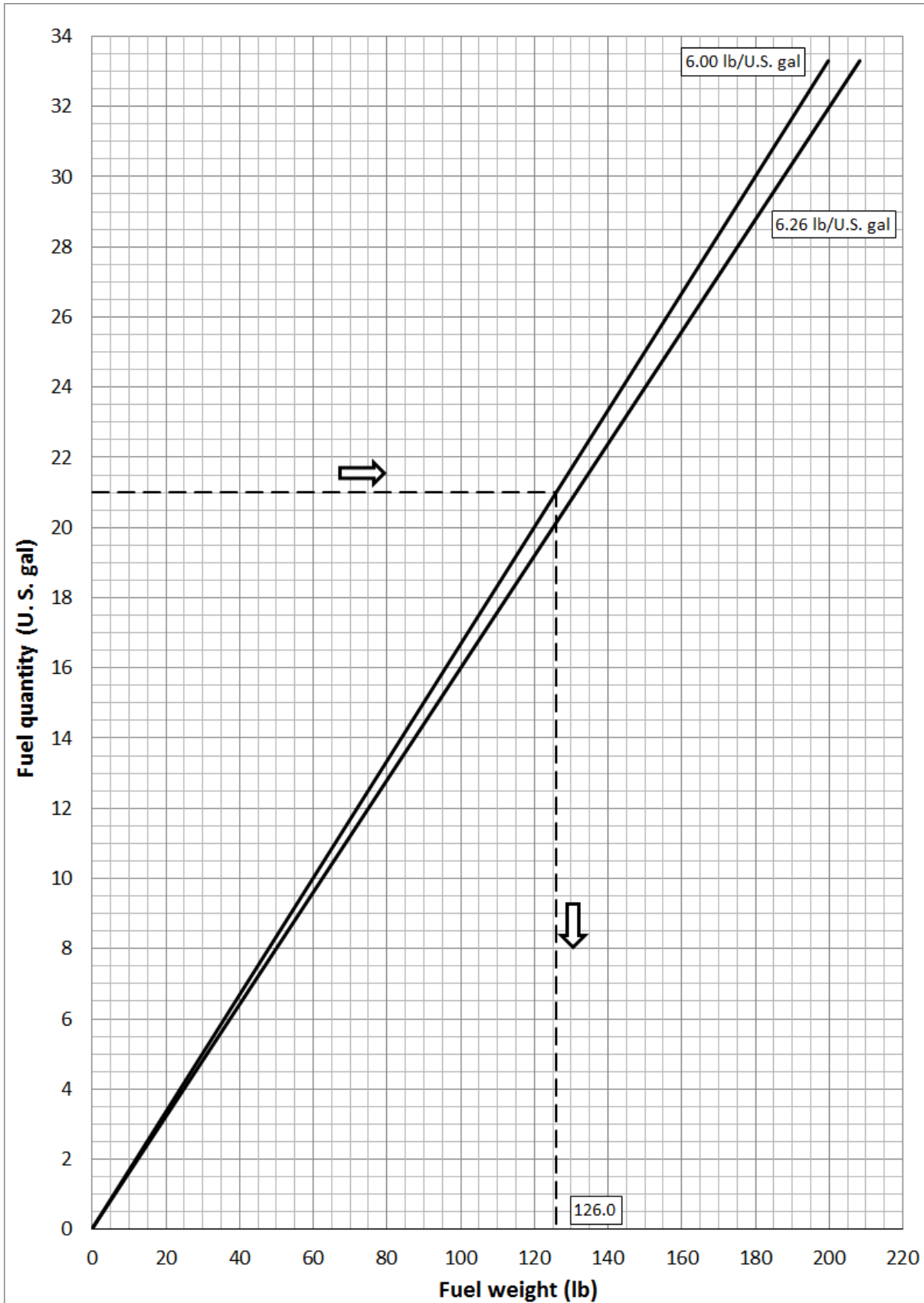

Fig. 6-8 Fuel quantity and weight conversion chart – U. S. Standard Units

### 6.6 Weight and Moment Limits Chart

#### 6.6.1 Metric Units

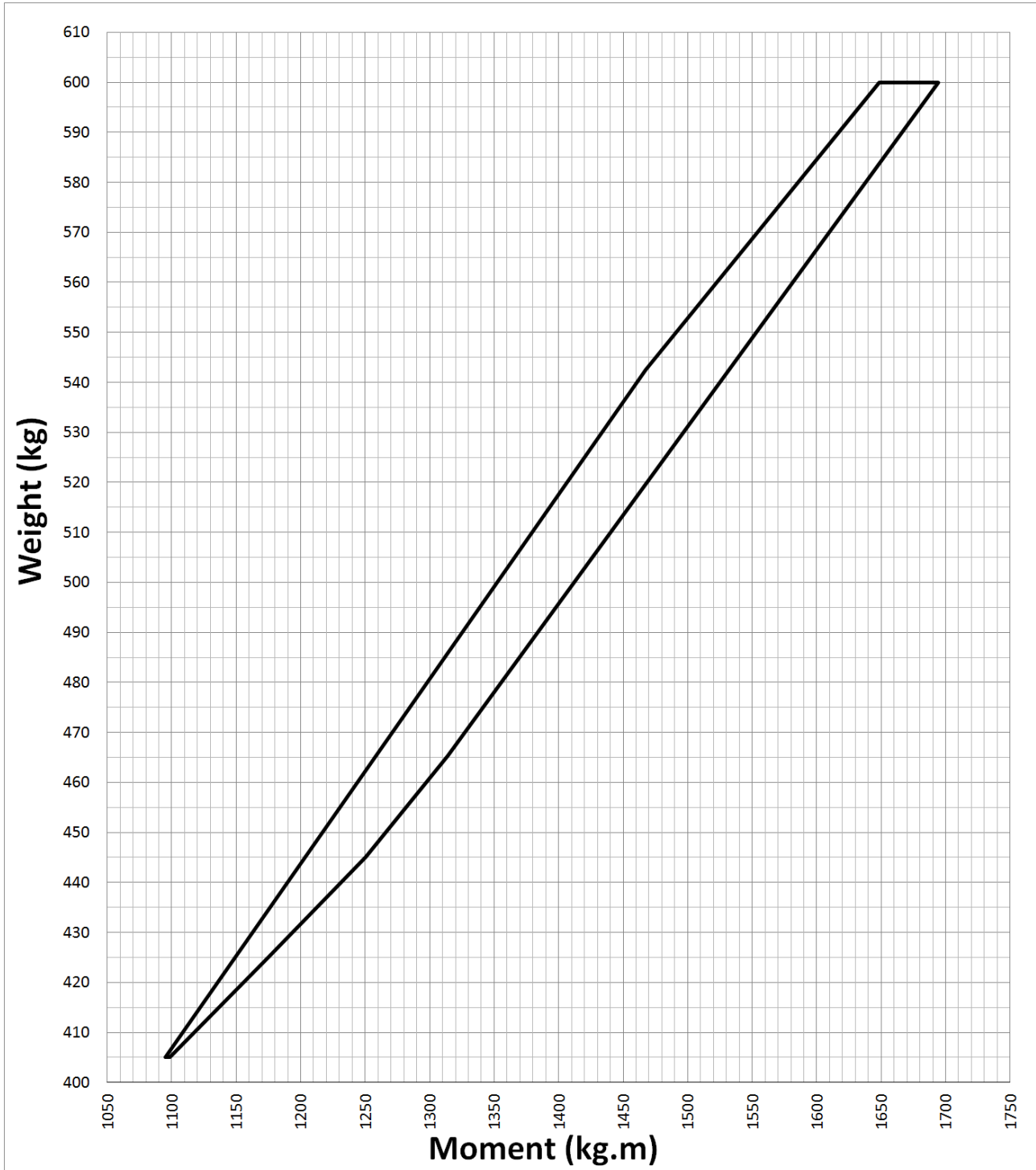

Fig. 6-9 Operating weight and moment chart – Metric Units

6.6.2 U. S. Standard Units

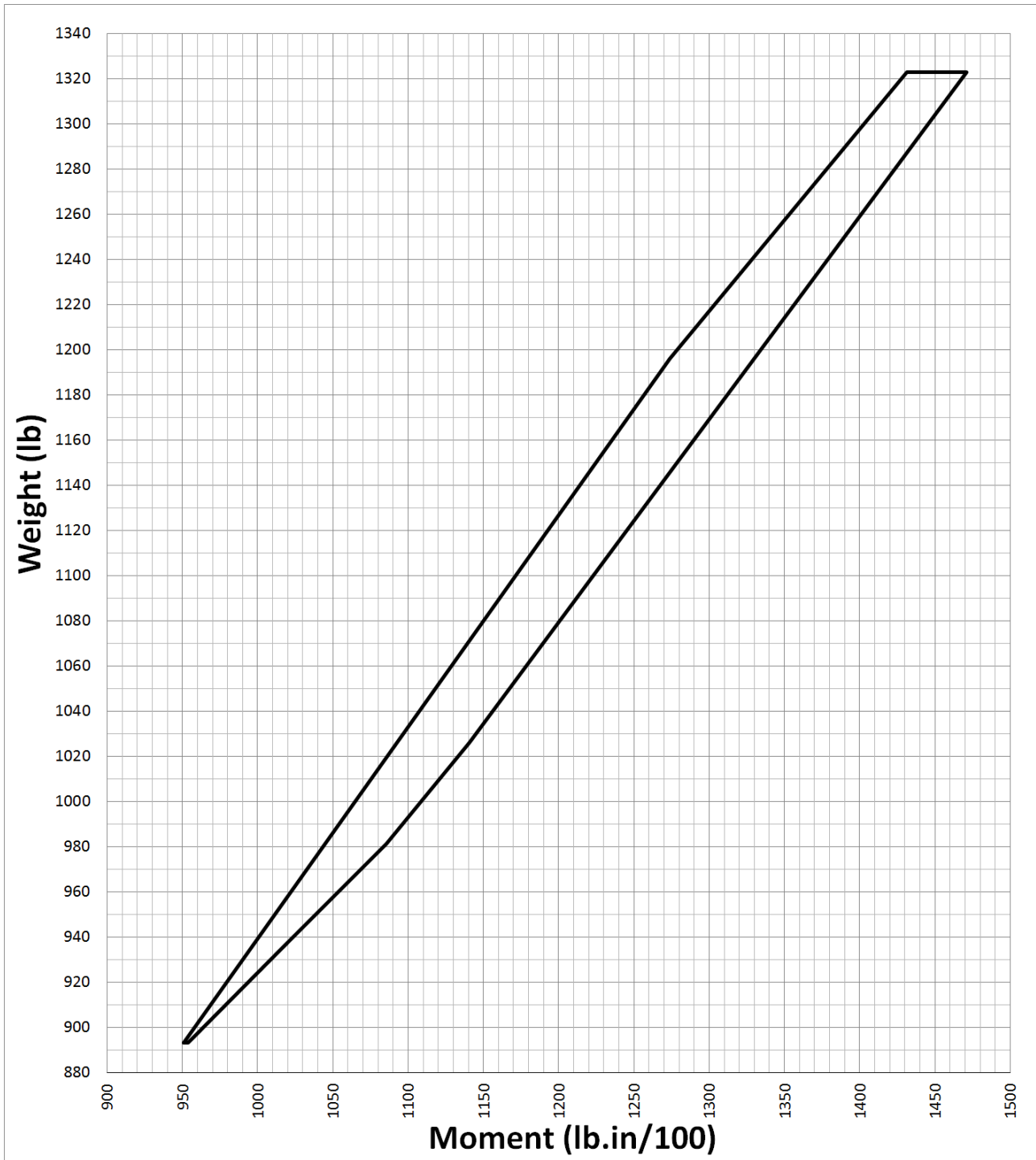

Fig. 6-10 Operating weight and moment chart – U. S. Standard Units

### 6.7 Equipment List

Actual Equipment List is shown in Chapter 9, Supplement No. 001.

# 7 DESCRIPTION OF AIRCRAFT AND SYSTEMS

## TABLE OF CONTENTS

<b>7.1</b>	<b>GENERAL .....</b>	<b>7-3</b>
<b>7.2</b>	<b>AIRFRAME .....</b>	<b>7-3</b>
7.2.1	Fuselage.....	7-3
7.2.2	Wing .....	7-3
7.2.3	Empennage.....	7-3
<b>7.3</b>	<b>FLIGHT CONTROLS .....</b>	<b>7-4</b>
7.3.1	Aileron Control System and Roll Trim .....	7-4
7.3.2	Elevator Control System and Pitch Trim .....	7-5
7.3.3	Rudder Control System .....	7-6
<b>7.4</b>	<b>FLIGHT DECK ARRANGEMENT .....</b>	<b>7-7</b>
7.4.1	Left Section of Instrument Panel .....	7-10
7.4.2	Center Section of Instrument Panel.....	7-10
7.4.3	Right Section of Instrument Panel .....	7-11
7.4.4	Center Console and Pedestal Panel .....	7-12
<b>7.5</b>	<b>FLIGHT INSTRUMENTS .....</b>	<b>7-13</b>
7.5.1	Primary Flight Display.....	7-13
7.5.2	Altitude Indicator .....	7-17
7.5.3	Airspeed Indicator .....	7-17
7.5.4	Vertical Speed Indicator .....	7-17
7.5.5	Bank Indicator .....	7-17
7.5.6	Magnetic Compass .....	7-17
<b>7.6</b>	<b>GROUND CONTROL.....</b>	<b>7-17</b>
<b>7.7</b>	<b>WING FLAPS .....</b>	<b>7-18</b>
<b>7.8</b>	<b>LANDING GEAR.....</b>	<b>7-19</b>
7.8.1	Main Gear.....	7-19
7.8.2	Nose Gear.....	7-19
<b>7.9</b>	<b>BAGGAGE COMPARTMENTS .....</b>	<b>7-19</b>
<b>7.10</b>	<b>SEATS AND SAFETY BELTS .....</b>	<b>7-20</b>

<b>7.11</b>	<b>RUDDER PEDALS .....</b>	<b>7-21</b>
<b>7.12</b>	<b>CANOPY.....</b>	<b>7-22</b>
<b>7.13</b>	<b>CONTROL SYSTEM LOCK.....</b>	<b>7-23</b>
<b>7.14</b>	<b>ENGINE.....</b>	<b>7-24</b>
7.14.1	Engine Controls .....	7-25
7.14.2	Cooling System .....	7-25
7.14.3	Exhaust System .....	7-26
7.14.4	Air Induction System .....	7-26
7.14.5	Oil System.....	7-26
7.14.6	Ignition and Starter System.....	7-27
7.14.7	Engine Instruments .....	7-27
<b>7.15</b>	<b>PROPELLER .....</b>	<b>7-32</b>
<b>7.16</b>	<b>FUEL SYSTEM .....</b>	<b>7-33</b>
7.16.1	System Description.....	7-33
7.16.2	Fuel Management .....	7-35
7.16.3	Fuel Measurement System .....	7-35
<b>7.17</b>	<b>BRAKE SYSTEM .....</b>	<b>7-37</b>
<b>7.18</b>	<b>ELECTRIC SYSTEM .....</b>	<b>7-38</b>
<b>7.19</b>	<b>CABIN HEATING AND VENTILATION .....</b>	<b>7-39</b>
<b>7.20</b>	<b>PITOT-STATIC SYSTEM.....</b>	<b>7-41</b>
<b>7.21</b>	<b>STALL WARNING SYSTEM.....</b>	<b>7-42</b>
<b>7.22</b>	<b>EMERGENCY PARACHUTE SYSTEM .....</b>	<b>7-44</b>

## 7.1 General

This chapter provides a description and operation of the aircraft and its systems. Some equipment, primarily avionics is not described in this section. For detailed description and operation of this equipment refer to the Chapter 9, Supplements.

## 7.2 Airframe

### 7.2.1 Fuselage

The fuselage structure consists of glass and carbon fiber sandwich composite, that produces a smooth and seamless surface. The structure is stiffened using firewall, bulkheads, ribs, stiffeners and interior components creating the cockpit. Major items of the structure are main and auxiliary spars to which the wings are attached. Each wing is attached

to the fuselage by means of two main pins and one auxiliary pin.

The cockpit is limited by a firewall in the front and backrest in the rear. In the middle of the cockpit there is a center tunnel which divides the cockpit for left and right side. The cockpit provides seating for two adults and the seats are arranged side by side. The cockpit is non-pressurized.

There are front and rear baggage compartments. Each baggage compartment is divided in two sections by a center tunnel. The front baggage compartment is located under the occupant's knees in front of the main spar. Rear baggage compartment is located between the backrest and baggage compartment bulkhead. There are windows in the rear baggage compartment on the both sides of the fuselage.

Integral fuel tanks are located in the forward box of the wing center section on the left and right side of the fuselage.

### 7.2.2 Wing

The wing consists of glass and carbon fiber sandwich composite, that produces a smooth and seamless surface. The construction of the wing includes conventional design with main spar, rear shear web, root rib and fuel tank ribs. The upper and lower skins are bonded to the spars, ribs and rear shear web. Wing spar, rear shear web and skins form two torsion boxes. The wing tip is fitted a winglet.

The wing main spar is attached to the center section spar by means of two main pins. The rear shear web of the wing is attached to the auxiliary spar by means of one auxiliary pin.

There is an integral fuel tank in each wing situated in the forward box of the wing root section. The wing fuel tank is connected to the fuselage fuel tank by a simple hose connection. The wing and fuselage tanks are also conductively connected.

### 7.2.3 Empennage

The conventional cruciform tail consists of a vertical stabilizer with a rudder, and horizontal stabilizer with elevator.

The vertical stabilizer consists of glass and carbon fiber sandwich composite. The construction of the vertical stabilizer includes skin, rear web and tip rib. The vertical stabilizer is an integral part of the fuselage. The rudder is attached to the vertical stabilizer's rear web by means of three hinges.

The horizontal stabilizer consists of glass and carbon fiber sandwich composite. The horizontal stabilizer is a single composite structure from tip to tip. It is bonded to the fuselage. The construction of the horizontal stabilizer includes upper and lower skin, partial span middle webs, rear web and root ribs. The two-piece elevator is attached to the horizontal stabilizer rear web by means of four hinges and one center hinge.

### 7.3 Flight Controls

The aircraft has conventional flight control systems for ailerons, elevator and rudder. The aircraft has dual controls with two control sticks and two pairs of rudder pedals.

Pitch trim and roll trim are electrically controlled by a switch on the pedestal panel.

#### 7.3.1 Aileron Control System and Roll Trim

The ailerons provide aircraft roll control. The aileron consists of glass and carbon fiber sandwich composite, that produces a smooth and seamless surface. The construction of the aileron includes skin, web, root and tip ribs. The aileron is attached to the upper skin of the wing by means of three hinges. The aileron has a mass balance weight attached in front of hinge line. The right aileron is fitted with a trim tab (roll trim). The gap between aileron and wing is sealed using sealing tapes. The effectiveness of the control surface decreases if the sealing tapes become unglued.

The ailerons are controlled by control sticks through a mechanical linkage consisting of push-pull rods and levers (Fig. 7-1).

The aircraft is equipped with an electrically operated roll trim. The trim tab consists of glass and carbon fiber composite. The trim tab is attached to the aileron by means of composite piano hinge. The trim tab is deflected by an actuator installed in the aileron. The actuator is operated by a rocker switch labelled **ROLL** installed on the pedestal panel. Position of roll trim is indicated by Dynon SkyView SV-D1000. Green line marks the neutral position of roll trim (trim tab and aileron trailing edge are aligned).

**CAUTION**  
Loose or missing sealing tapes cause significant decrease of control surface effectiveness!

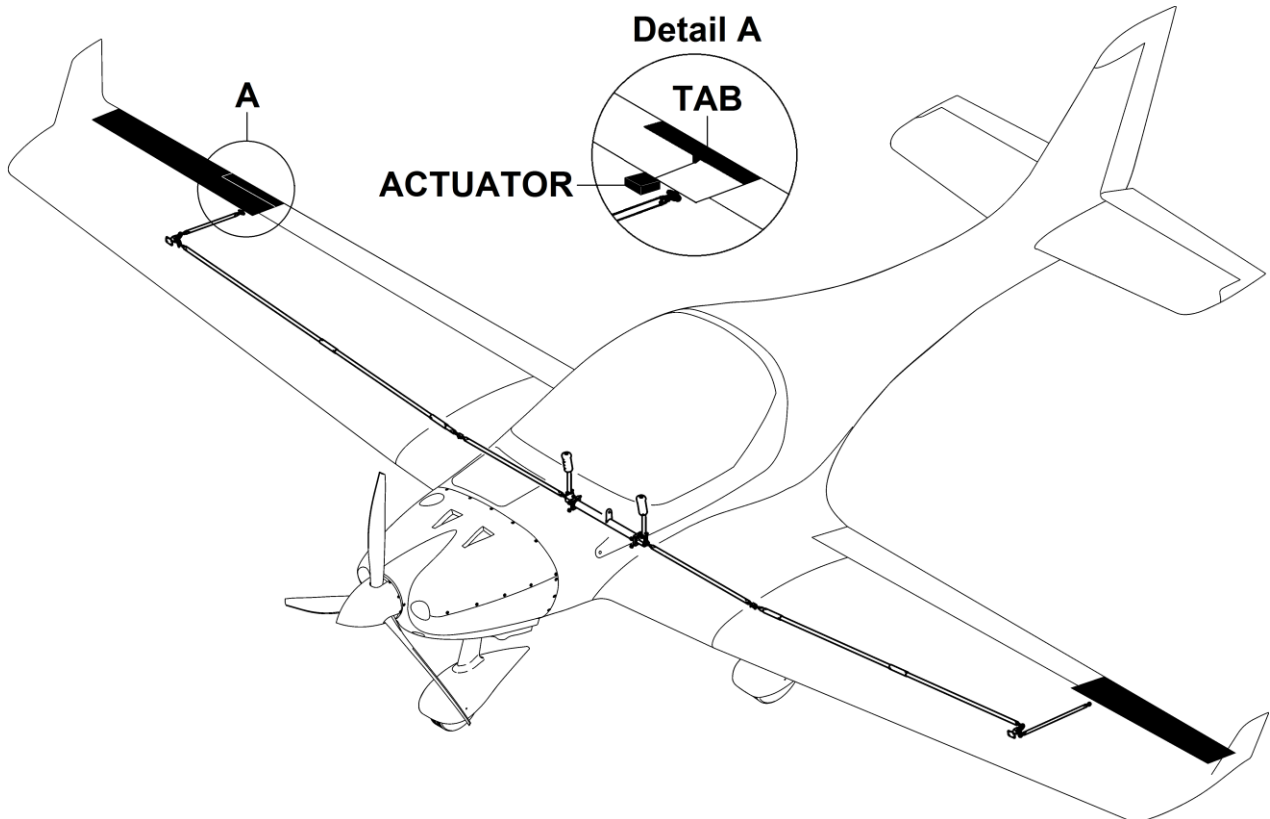

Fig. 7-1 Aileron control



### 7.3.2 Elevator Control System and Pitch Trim

The two-piece elevator provides aircraft pitch control. The elevator consists of glass and carbon fiber sandwich composite, that produces a smooth and seamless surface. The construction of the elevator includes skin, root and tip rib. Each piece of elevator is attached to the horizontal stabilizer by means of two hinges and one center hinge in the middle that joints both pieces of the elevator. Each piece of elevator has a mass balance weight located in its horn. The gap between elevator and horizontal stabilizer is sealed by the sealing tapes. Loose or missing sealing tapes cause a significant decrease of the effectiveness of the control surfaces.

The elevator is controlled by control sticks through mechanical linkage consisting of push-pull rods and levers. There is a bob weight connected to the elevator control system by means of the push-pull rod (Fig. 7-2).

The aircraft is equipped with an electrically operated pitch trim. The pitch trim system deflects the elevator. The pitch trim consists of two tension springs attached to the elevator control push-pull rod and lever in the center tunnel. The lever is deflected by an actuator. The actuator is operated by a rocker switch labelled **PITCH** installed on the pedestal panel. The actuator is equipped with two-speed regulator. The trim system operates at slow speed when clicking the rocker switch (fine adjustments) and high speed when pressing and holding the rocker switch (rapid adjustments).

Position of pitch trim is indicated by Dynon SkyView SV-D1000. Green line marks the neutral position of pitch trim (elevator is set in neutral position by activating trim system).

#### CAUTION

Loose or missing sealing tapes cause significant decrease of control surface effectiveness!

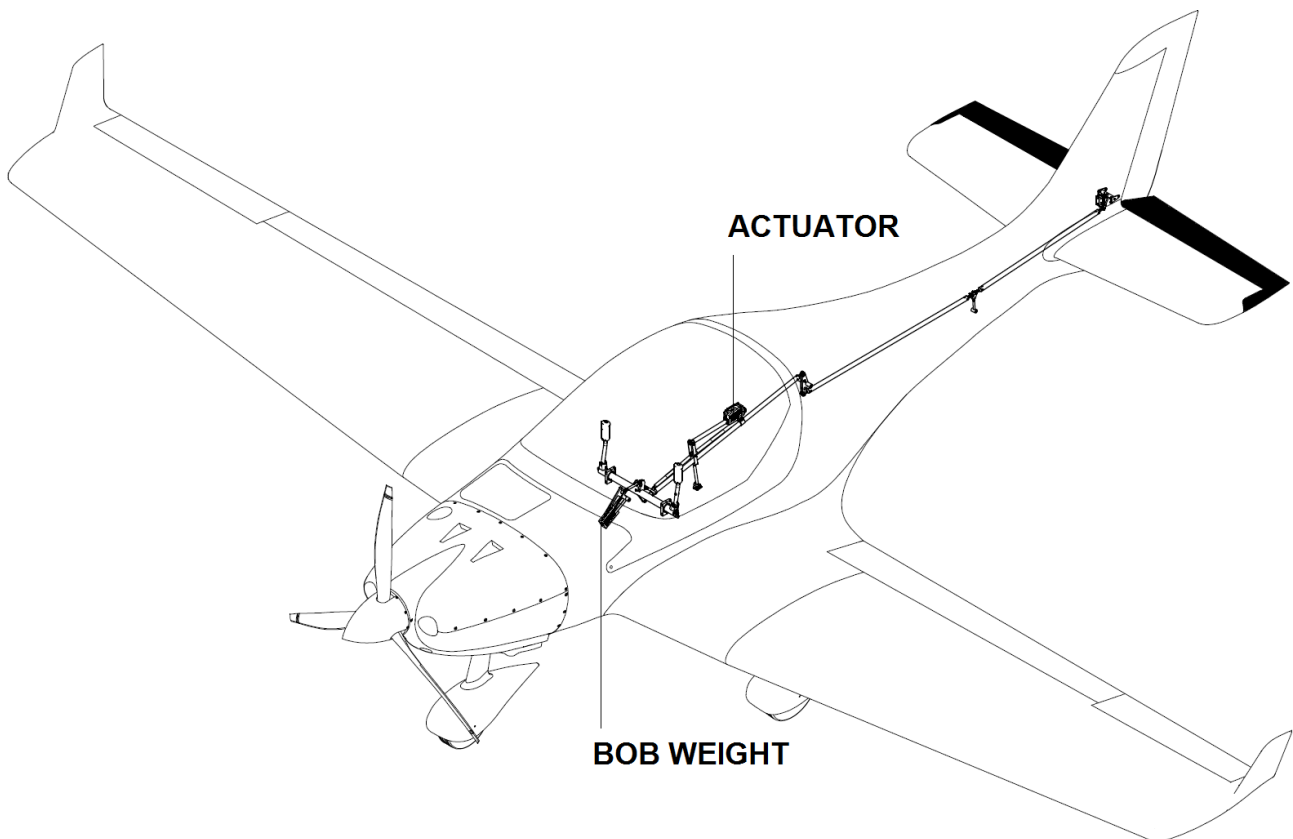

Fig. 7-2 Elevator control

### 7.3.3 Rudder Control System

The rudder provides aircraft directional (yaw) control. The rudder consists of glass and carbon fiber sandwich composite, that produces a smooth and seamless surface. The construction of rudder includes skin, root and tip rib. The rudder is attached to the vertical stabilizer's rear web by means of three hinges. The rudder has a mass balance weight located in its horn. The gap between rudder and vertical stabilizer is sealed by the sealing tapes. Unglued sealing tapes cause a decrease of the effectiveness of the control surface.

The rudder is controlled by rudder pedals through a mechanical linkage consisting of steel cables. Rudder pedals also allows steering of the nose gear leg to which is connected by means of push-pull rods (Fig. 7-3).

#### CAUTION

Loose or missing sealing tapes cause significant decrease of control surface effectiveness!

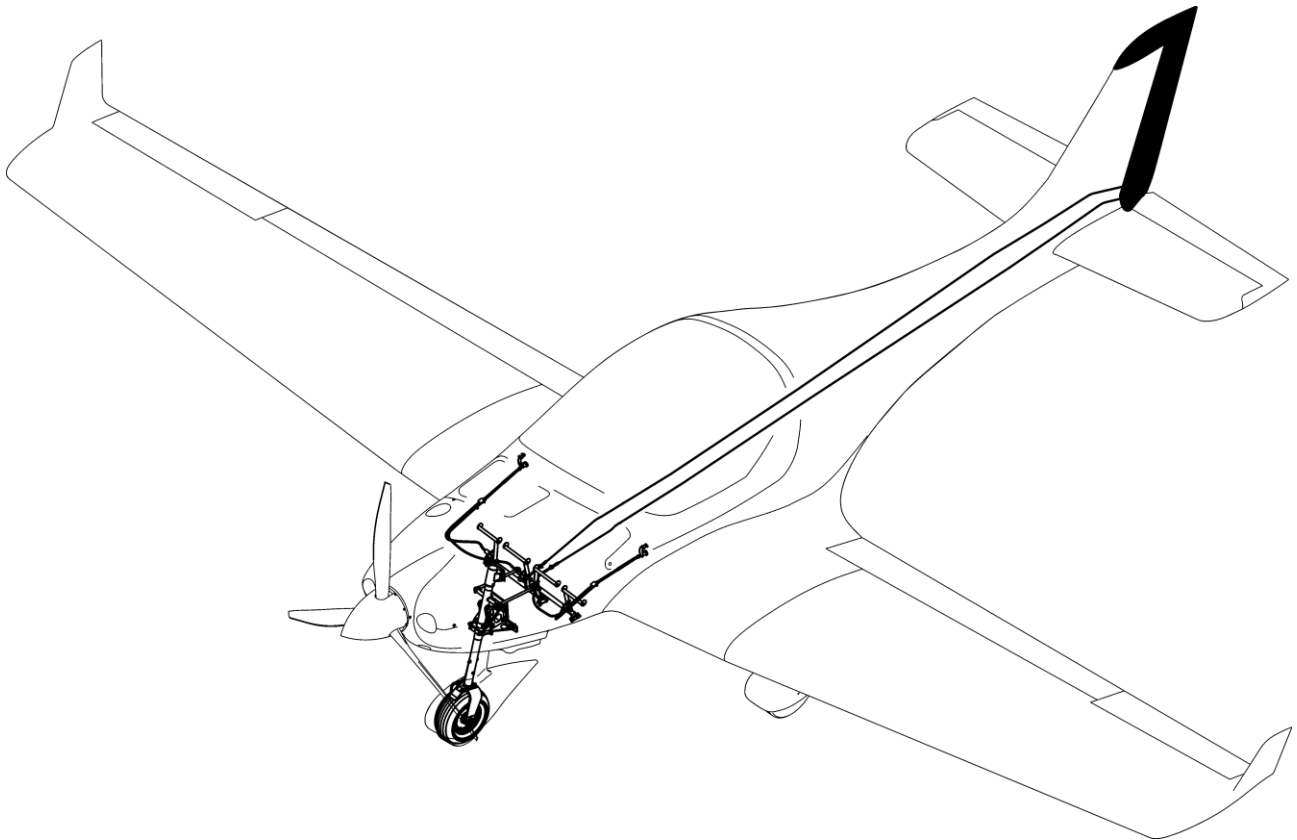
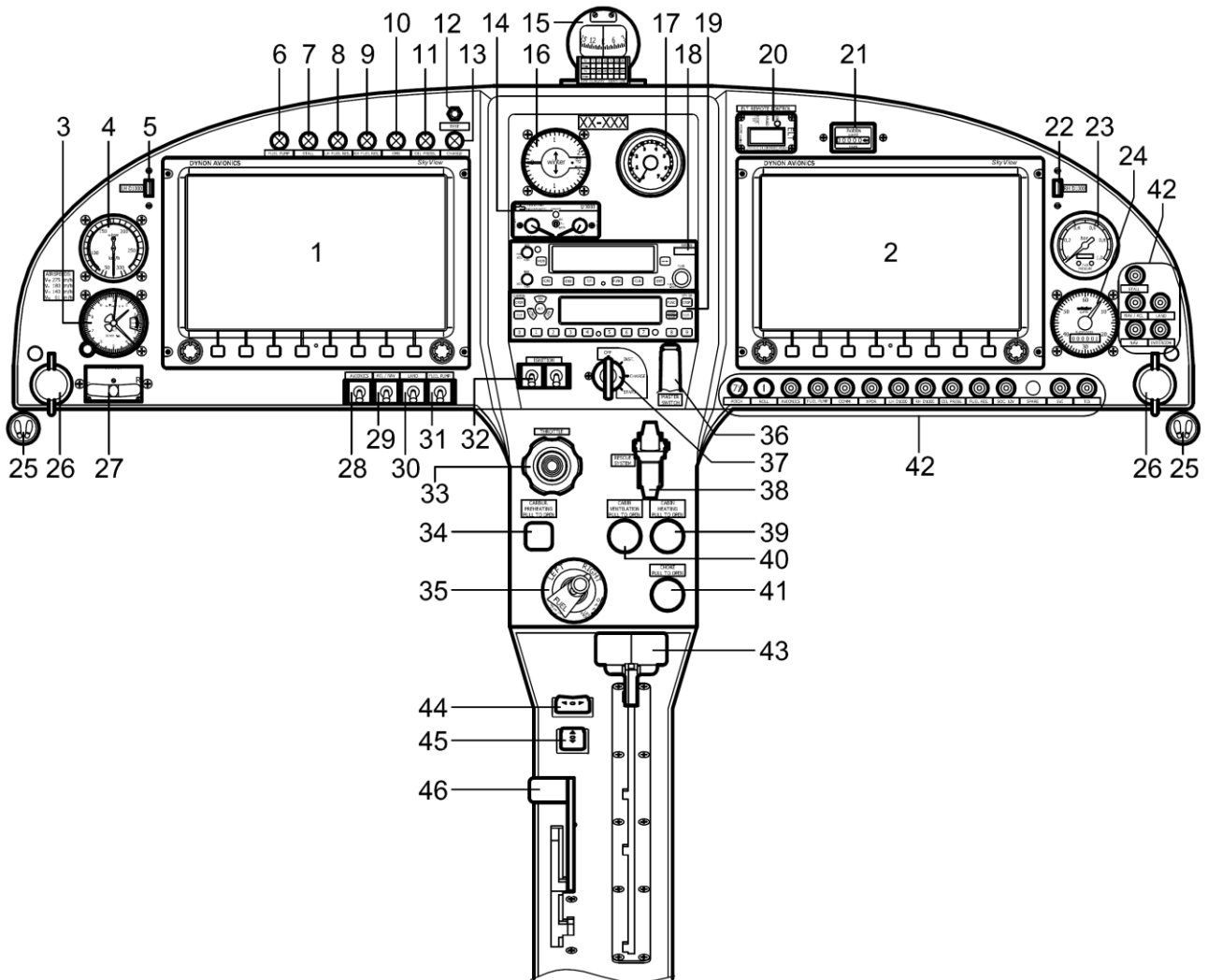

Fig. 7-3 Rudder control

### 7.4 Flight Deck Arrangement

The instrument panel is glass/carbon composite construction attached to the center tunnel and both sides of fuselage. In the middle, the top edge is supported with a composite strut. Glare shield overlaps the instrument panel to limit undesirable reflections on instruments. The instrument panel is divided into three sections: left, center and right. Controls are also installed on the center console and pedestal panel. On both the left and right side under the instrument panel there are remote controls for adjustment of rudder pedals. The instrument panel is arranged primarily for use by the pilot sitting in the left seat (Fig. 7-4).



Layout valid from S/N 17001 to 20005 inclusive

Fig. 7-4 Instrument panel layout (page 1 of 3)

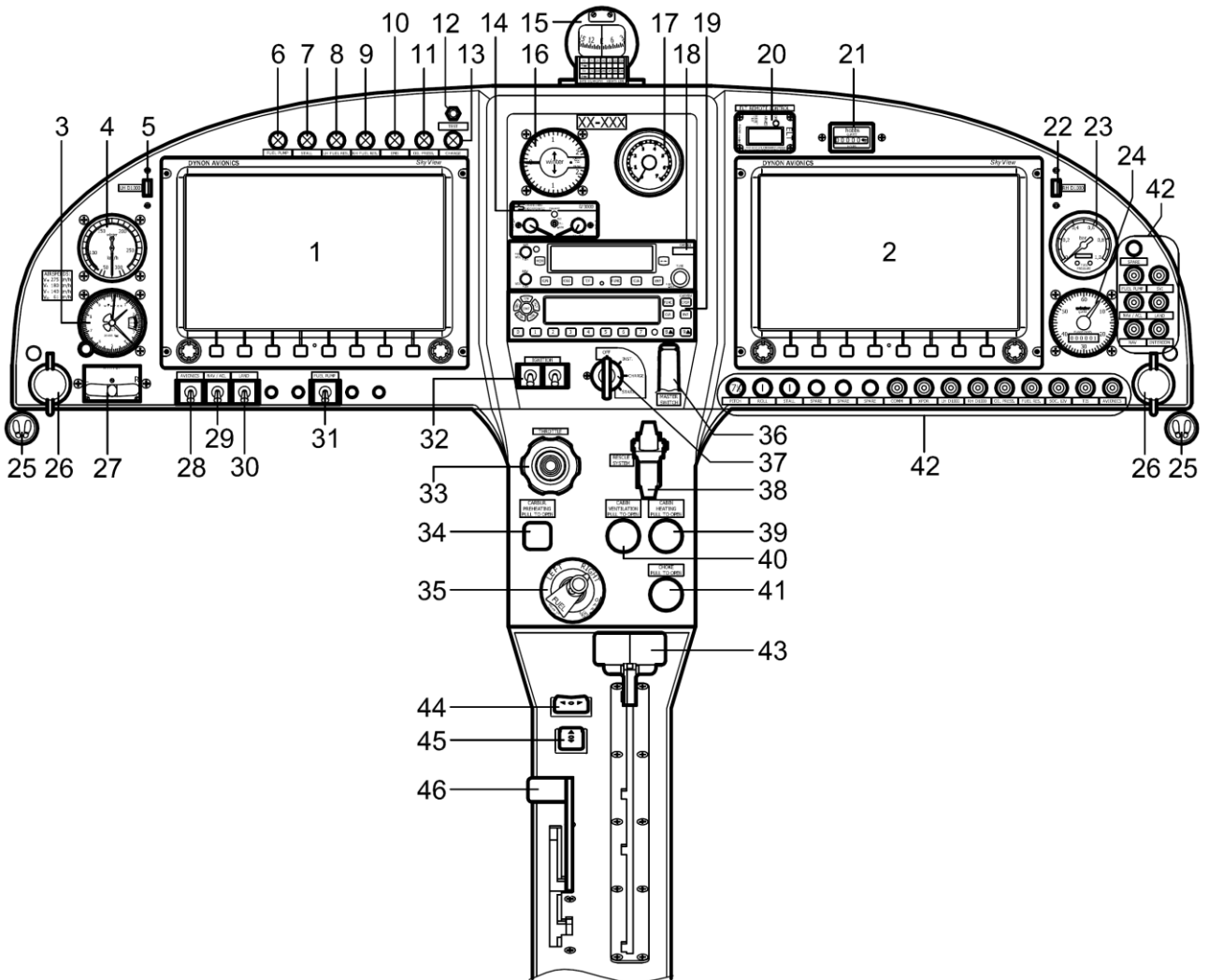

Layout valid from S/N 21001

Fig. 7-4 Instrument panel layout (page 2 of 3)

1.	PFD Dynon SkyView SV-D1000	24.	Flying hours counter*
2.	MFD Dynon SkyView SV-D1000	25.	Pedal's adjustment handle
3.	Standby altimeter*	26.	12 V / 10 A power outlet
4.	Standby airspeed indicator*	27.	Standby slip indicator*
5.	USB connector ( <b>LH-D1000</b> )	28.	<b>AVIONICS</b> switch
6.	<b>FUEL PUMP</b> control lamp	29.	<b>NAV / ACL</b> lights switch
7.	<b>STALL</b> warning lamp	30.	<b>LAND</b> lights switch
8.	<b>LH FUEL RES.</b> warning lamp - left tank	31.	<b>FUEL PUMP</b> switch
9.	<b>RH FUEL RES.</b> warning lamp - right tank	32.	<b>IGNITION</b> switches
10.	<b>EMS</b> warning lamp	33.	<b>THROTTLE</b> controller
11.	<b>OIL PRESS.</b> warning lamp	34.	<b>CARBUR. PREHEATING</b> controller
12.	Lamps and stick shaker <b>TEST</b> button	35.	<b>FUEL</b> selector*
13.	<b>CHARGE</b> warning lamp	36.	<b>MASTER SWITCH</b>
14.	Intercom*	37.	Starter key
15.	Magnetic compass*	38.	<b>RESCUE SYSTEM</b> actuator
16.	Standby variometer*	39.	<b>CABIN HEATING</b> control
17.	Standby RPM indicator*	40.	<b>CABIN VENTILATION</b> control
18.	Radio*	41.	<b>CHOKE</b> control
19.	Transponder*	42.	Circuit breakers (see Chapter 7.4.3)
20.	ELT remote control	43.	<b>FLAPS</b> control
21.	Engine hours counter*	44.	<b>ROLL</b> trim control
22.	USB connector ( <b>RH-D1000</b> )	45.	<b>PITCH</b> trim control
23.	Standby fuel pressure indicator*	46.	Brake lever

\* For actual installed equipment, see Chapter 9, Supplement No. 001.

Fig. 7-4 Instrument panel layout (page 3 of 3)

### 7.4.1 Left Section of Instrument Panel

PFD Dynon SkyView SV-D1000 is installed in the middle of the left section. The PFD is landscape oriented intended to primary displays the flight information. There is also a USB connector on the left side of PFD labelled **LH D1000** that is intended to import flight plans and export logs.

In this section, the following standby instruments are installed: airspeed indicator, altimeter and slip indicator.

Under the PFD in the right lower corner of left section are switches **AVIONICS**, **NAV / ACL** (navigation lights / anti-collision), **LAND** (landing lights) and **FUEL PUMP**.

Above the PFD is an area for control and warning lamps **FUEL PUMP**, **STALL**, **LH FUEL RES.**, **RH FUEL RES.**, **EMS**, **OIL PRESS.** and **CHARGE**. This area includes also **TEST** button for the check of lamp's and stick shaker's function.

In the left lower corner 12 V / 10 A power socket output is located.

#### CAUTION

The USB connector is not intended for charging devices!  
The power socket is intended for power supply of external devices only!

#### NOTE

For complete operating procedures of appropriate equipment refer to OEM manuals.

### 7.4.2 Center Section of Instrument Panel

In the center section there are installed transponder, radio, intercom, standby variometer and standby RPM indicator.

At the top of center section on the glare shield there is installed standby magnetic compass.

At the bottom of center section there are installed **IGNITION** switches, keyed ignition switch and **MASTER SWITCH**.

#### NOTE

For complete operating procedures of appropriate equipment refer to OEM manuals.

### 7.4.3 Right Section of Instrument Panel

MFD Dynon SkyView SV-D1000 is installed in the middle of right section. The MFD is landscape oriented intended to primary display the engine information. There is also a USB connector on the right side of MFD labelled **RH D1000** that is intended to import flight plans and export logs.

In this section is installed standby fuel pressure indicator, flying hours counter and Engine Hours Counter.

Remote control of the Emergency Locator Transmitter (ELT) is located above the MFD.

Circuit breakers are placed in a row at the lower and right side of right section. A list of circuit breakers with protected instruments is shown in the table below.

In the right lower corner 12 V / 10 A power socket output is located.

#### CAUTION

The USB connector is not intended for charging devices!  
The power socket is intended for power supply of external devices only!

#### NOTE

For complete operating procedures of appropriate equipment refer to OEM manuals.

Marking	Protected instrument
PITCH	Pitch trim actuator
ROLL	Roll trim actuator
STALL	Stall warning system
AVIONICS	Avionics relay
FUEL PUMP	Fuel pump
COMM	Radio (COMM)
XPDR	Transponder
LH D1000	PFD (LH Dynon SkyView SV-D1000)
RH D1000	MFD (RH Dynon SkyView SV-D1000)
OIL PRESS.	Low oil pressure warning
FUEL RES.	Low fuel level warning
SOC. 12V	LH and RH socket 12 V / 10 A
SVI	Engine hours counter Flight hours counter RPM indicator
TIS	Traffic sensor
SPARE	-
NAV / ACL	Navigation and Anti-collision lights
LAND	Landing lights
NAV	Radio (NAV)
INTERCOM	Intercom

#### **7.4.4 Center Console and Pedestal Panel**

The center console is located under the instrument panel and contains the following controls:

- Throttle control labelled **THROTTLE**
- Emergency parachute system actuator labelled **RESCUE SYSTEM**
- Carburetor preheating control labelled **CARBUR. PREHEATING PULL TO OPEN**
- Cabin venting control labelled **CABIN VENTILATION PULL TO OPEN**
- Cabin heating control labelled **CABIN HEATING PULL TO OPEN**
- **FUEL** selector
- Choke control labelled **CHOKE PULL TO OPEN**

The pedestal panel is located between pilot and co-pilot and contains the following controls:

- Wing flap control with positions **FLAPS 0, FLAPS 1, FLAPS 2** and **FLAPS 3**
- Roll trim control labelled **ROLL**
- Pitch trim control labelled **PITCH**
- Brake lever with positions **PARK** and **MAX**



## 7.5 Flight Instruments

### WARNING

Carefully read the accompanying documentation of all installed avionics before the flight! Do not learn how to operate the avionics during flight!

### 7.5.1 Primary Flight Display

Aircraft is fitted with PFD Dynon SkyView SV-D1000 (LH display) which displays flight parameters listed below. PFD also displays engine parameters listed in the Chapter 7.14.7.

- Airspeed indicator
- Altimeter
- Attitude indicator
- Vertical speed indicator
- Slip/Skid ball
- Compass rose / directional gyro
- G-meter
- OAT
- Angle of attack indicator
- Traffic information
- Other data: time, radio and transponder status

### NOTE

For more details refer to Dynon Avionics SkyView System Pilot's Guide, Document No. 101321-016 (revision Q or later).

PFD displays the information in the following screen arrangements:

- EFIS with compass rose / EMS (Fig. 7-5)
- EFIS with g-load indication / EMS (Fig. 7-6)
- EFIS with analogue instruments design / EMS (Fig. 7-7)
- EFIS with compass rose / MAP / EMS (Fig. 7-8)
- EFIS with g-load indication / MAP / EMS (Fig. 7-9)
- EFIS with analogue instruments design / MAP / EMS (Fig. 7-10)

Note: If g-loads (0.0 / +2.0) are exceeded, the compass rose is automatically replaced by g-load indication.

### NOTE

The airspeed indicator on the screen arrangements is displayed in km/h only for illustration.



Fig. 7-5 Arrangement screen 1



Fig. 7-6 Arrangement screen 2



Fig. 7-7 Arrangement screen 3



Fig. 7-8 Arrangement screen 4



Fig. 7-9 Arrangement screen 5



Fig. 7-10 Arrangement screen 6

### 7.5.2 Altitude Indicator

Aircraft altitude is displayed by PFD Dynon SkyView SV-D1000 and standby altimeter. The ADAHRS module (PFD) and standby altimeters sense the local barometric pressure adjusted for altimeter setting and display the result on the instruments in feet.

Barometric windows allow barometric calibration in millibars (mbar). The barometric altimeter setting of PFD altimeter is input through the knob when set to **BARO**. Barometric altimeter setting of standby altimeter is input through the barometric adjustment knob at the lower left of the instrument.

### 7.5.3 Airspeed Indicator

Aircraft airspeed is displayed by PFD Dynon SkyView SV-D1000 and standby airspeed indicator. The ADAHRS module (PFD) and standby airspeed indicator sense the difference in static and total pressure and display the result in km/h (optional knots).

Airspeed indicator on PFD Dynon SkyView SV-D1000 displays indicated airspeed, true airspeed (TAS) and ground airspeed (GS).

Standby airspeed indicator displays indicated airspeed only.

Airspeed indicators have color marking according to Chapter 2.2.1.

### 7.5.4 Vertical Speed Indicator

Aircraft rate of climb is displayed by PFD Dynon SkyView SV-D1000 and standby vertical speed indicator. The ADAHRS module (PFD) and standby vertical speed indicator sense the rate of change in static pressure from a reference pressure and displays the result in climb or descent in feet per minute.

### 7.5.5 Bank Indicator

Bank indicator is displayed by the PFD Dynon SkyView SV-D1000. In addition, standby slip indicator is installed on the left section of the instrument panel.

### 7.5.6 Magnetic Compass

Magnetic compass is displayed by PFD Dynon SkyView SV-D1000. In addition, standby magnetic compass is installed in the center section on the instrument panel glare shield.

## 7.6 Ground Control

Rudder pedals (see Chapter 7.11) are connected to the nose gear leg by means of push-pull rods and allow steering of nose wheel (Fig. 7-3). Minimum radius of turn for ground handling is in Chapter 1.3.5.

### 7.7 Wing Flaps

The single-slotted wing flaps provide low speed lift enhancement. The wing flap consists of glass and carbon fiber sandwich composite, that produces a smooth and seamless surface. The construction of flap includes skin, web, root and tip rib. The flap is attached to the wing and fuselage by means of four hinges.

The wing flaps are operated manually by a lever on the pedestal panel. The wing flap lever moves in a slotted link which indicates four positions: **FLAPS 0** (flaps retracted 0°), **FLAPS 1** (takeoff position 15°), **FLAPS 2** (landing position 24°) and **FLAPS 3** (emergency landing position 35°). Wing flap lever is joined to the flap's torsion tube by means of push-pull rod and lever. Torsion tube mechanically interconnects both wing flaps. There is a booster (gas strut) in the flap control system. The booster decreases the pilot effort when extending the wing flaps.

The flaps position is set by gripping the handle, pressing the buttons on the underside of the handle with fingers and pulling the handle to the desired position. The position is automatically locked after the buttons are released (Fig. 7-11).

**WARNING**  
Do not extend the flaps above  $V_{FE}$ !

**WARNING**  
When setting the flap position **FLAPS 1**, **FLAPS 2** or **FLAPS 3** always ensure that the lever is properly locked!  
If not locked properly, the flaps may retract inadvertently, which will cause the aircraft to pitch up and lose airspeed quickly!

**NOTE**  
Always extend the flaps gradually through incremental positions and trim the aircraft appropriately!

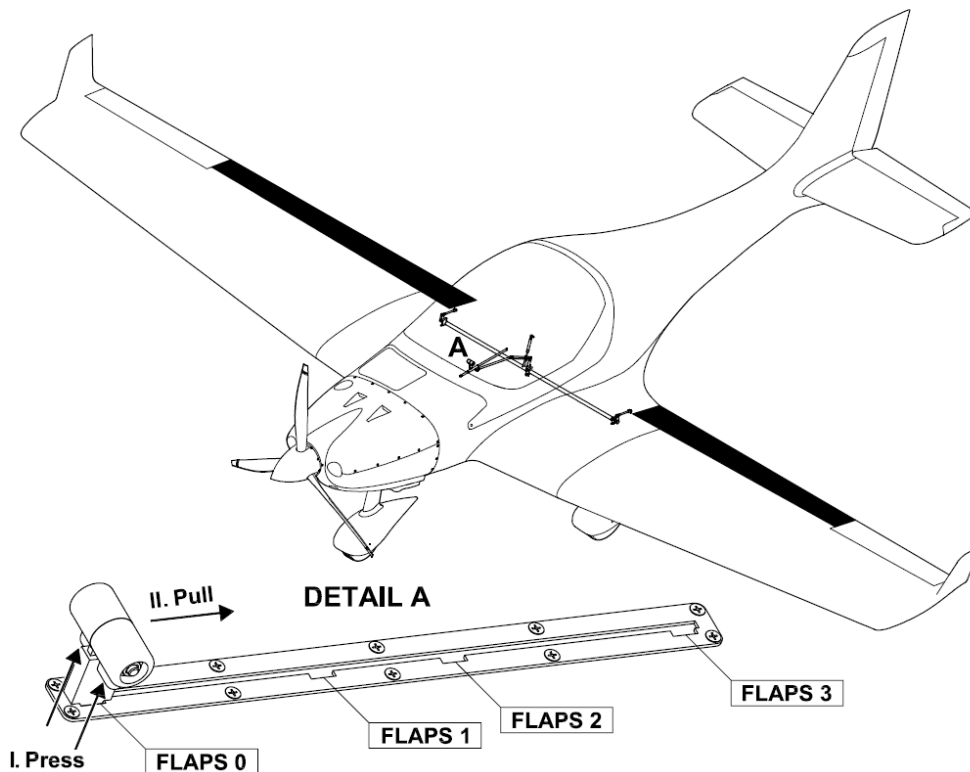

Fig. 7-11 Wing flaps control

## 7.8 Landing Gear

The aircraft is equipped with a fixed landing gear, nose wheel type.

### 7.8.1 Main Gear

Main landing gear consists of composite legs that are attached to the ribs of fuselage center section. The main wheels are bolted to the composite legs. The main wheels are equipped with hydraulically operated single-disc type brakes.

Each main wheel has a 15x6.00-6 tubeless tire installed.

The main wheels are equipped with wheel fairings. The wheel fairings are removable to provide access to the tires and brakes.

### 7.8.2 Nose Gear

The nose gear leg is tubular steel construction attached to the firewall. The nose wheel is steerable, controlled by the rudder pedals. The suspension is ensured by means of rubber damper and rubber bungies.

The nose wheel has a 13x5.00-6 tubeless tire installed.

The nose wheel is equipped with a wheel fairing. The wheel fairing is removable to provide access to the tire.

Nose gear is equipped with a centering spring mechanism that returns the nose wheel and rudder to the neutral position.

## 7.9 Baggage Compartments

The aircraft has two locations where the baggage can be placed.

The front baggage compartment is located in front of main spar under the pilot/co-pilot knees. A center tunnel divides the front baggage compartment into left and right sections. Each section is equipped with 4 attachment points for baggage restraints. The front baggage compartment may be used only with installed original manufacturer's bags that are closed and restrained during flight. Front baggage compartment is suitable for small items.

Rear baggage compartment is located between the occupant's backrest and baggage bulkhead. A center tunnel divides the rear baggage compartment into left and right sections. Each section is equipped with 4 attachment points for baggage restraints. Rear baggage compartment is suitable for longer or bulky items. The baggage must be restrained.

To restrain the baggage:

- Thread the straps through the attachment points and position them over baggage. If possible, thread the straps through the baggage handles.
- Tighten the straps to restrain the baggage and lock the buckle.

To loosen the baggage:

- Release the buckle and loosen the straps.
- Slip out the baggage from the straps

### WARNING

All baggage must be safely restrained before the flight!  
Loose objects in front baggage comp. may block the controls!  
Loose objects in rear baggage comp. may injure the occupants!

### WARNING

The maximum baggage weight must not be exceeded!  
The baggage weight must be included in the weight and balance calculation!

### 7.10 Seats and Safety Belts

There are seats for two occupants in the cockpit. The shape of cockpit and removable composite seat pan forms the seat. The seat is equipped with removable upholstered cushions.

Each seat is equipped with 4-point safety belts. Waist belts are attached to the center tunnel and interior sidewalls and harness belts are attached to the backrest.

To use the safety belts (Fig. 7-12):

- Sit in a comfortable position and centre the buckle (F) over hips for maximum comfort and safety.
- Insert the waist belt anchor (A) into buckle (F) and lock it.
- Thread the harness belts over the shoulders, insert the belt anchors (B) into the buckle (F) and lock them. To loosen the belts, pull the top edge of adjusting clip (D) outwards and loosen the belt (E) as required.
- Tighten the seat belts by pulling the loose ends (C). Seat belts should fit snugly against the shoulder with the lap buckle centre and tightened around the hips.

To release the safety belts (Fig. 7-12):

- Turn the buckle (F) to release the belt anchors (G).

**WARNING**

The pilot and passenger must use the safety belts during all phases of the flight! The safety belts (waist and shoulder belts) must be securely fastened!

**WARNING**

Safety belts must be fastened even if the seat is unoccupied during the flight!

**CAUTION**

The seat bottom has a composite sandwich construction. To avoid crushing the seat structure, do not kneel or stand on the seats!

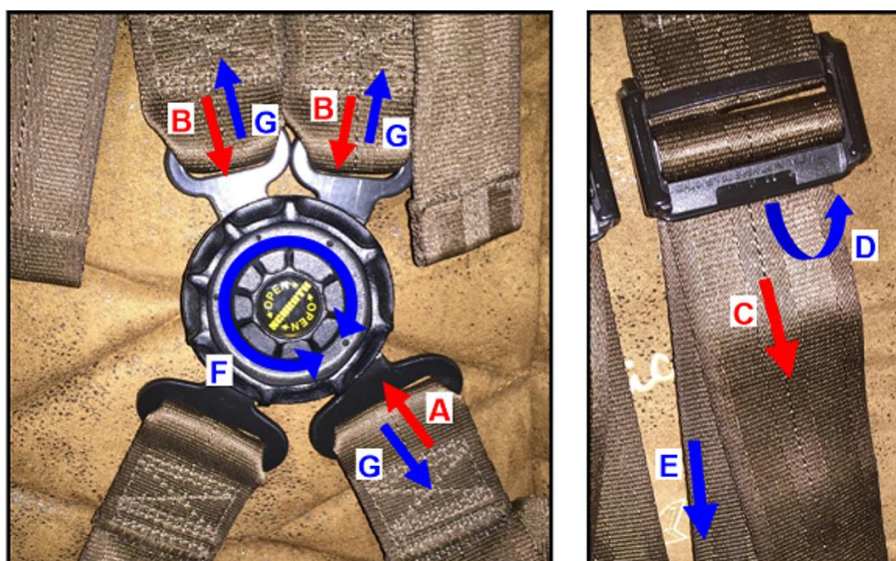

Fig. 7-12 Safety belts



### 7.11 Rudder Pedals

Position of rudder pedals is adjustable to three positions individually for both pilot and co-pilot. To adjust the pedals first set the rudder control to neutral position (nose gear straight). Pull the pedal's adjustment handle (Fig. 7-4). When the pedals are released, the springs will automatically try to set the pedals to aft position. Push both pedals equally to set them in mid or forward position. The position is locked when the handle is released.

#### **WARNING**

Never adjust the rudder pedals during flight!

### 7.12 Canopy

The cockpit canopy consists of one part. The windshield is bonded to the composite frame.

The canopy is hinged forward and opens upside-forward directions with the assistance of gas struts that counterbalance the weight of the canopy and hold the canopy open. Access to the cockpit is from both sides.

Canopy handle and lock levers are located in the center of canopy frame above the pilot / co-pilot. Canopy handle is used for lifting and closing the canopy from interior. The locking mechanism is used for safe locking of canopy and can be operated from interior and exterior by lock levers. The lock lever in the interior is equipped with a red ring indicating locked position of the canopy.

To open the canopy from outside, push the lock lever forwards with one hand (Fig. 7-13, A), grab the NACA intake on the canopy side with the other hand and pull to lift the canopy. To open the canopy from inside, pull the lock lever forwards with one hand (Fig. 7-13, A), grab the canopy handle with the other hand and push to lift the canopy.

To close the canopy from outside, grab the canopy handle and pull the canopy downwards until it latches, then press slightly on the canopy near the lock until the lock lever slides rearwards (Fig. 7-13, B). To close the canopy from inside, grab the canopy frame with one hand and lower the canopy. Then grab the canopy handle with the other hand and pull downwards until the lock lever slides rearwards and the red ring indicates correct locking. Push the canopy handle upwards slightly to ensure the canopy is properly latched and locked (Fig. 7-13, B).

Make sure that the canopy is latched and locked before operating the aircraft by pressing upwards on the canopy handle. Due to airflow and function of gas struts the canopy can open spontaneously during straight line flight or sideslip. Correct/incorrect latching and locking are illustrated on Fig. 7-13.

**CAUTION**  
Do not open/close the canopy by pulling/pushing of the gas struts or lock lever!

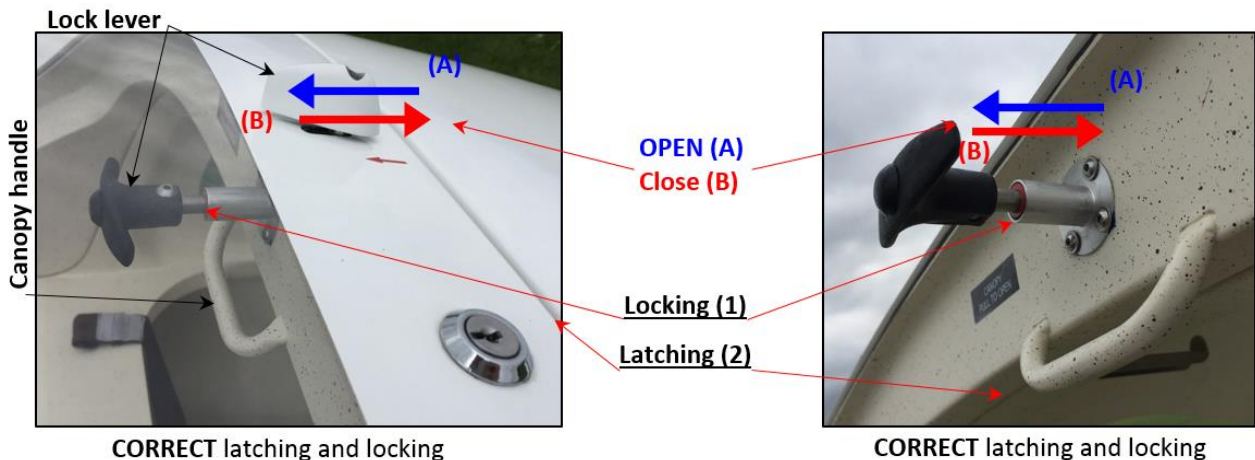

Latched (2) but unlocked (1)  
**WRONG!**



Latched (2) but partially locked (1)  
**WRONG!**



Clearly locked (1) but unlatched (2)  
**WRONG!**

Fig. 7-13 Canopy latching and locking

### 7.13 Control System Lock

The aircraft control system is not equipped with control locks.

The pitch trim spring has a sufficient power to act as a gust damper when the pitch trim is set fully forward.

The rudder control is connected with the nose wheel and this connection acts as a control lock.

To lock the aileron control systems set the ailerons to neutral position and fix them to the wing on the trailing edge using adhesive tape.

#### **WARNING**

Remove the aileron control locks before flight!

#### **CAUTION**

Set the pitch trim fully forward and engage the aileron control locks when parking the aircraft in windy weather to avoid of control system damage due to gusts!

### 7.14 Engine

Aircraft is powered by a 4 cylinder, horizontally opposed, air and water cooled, carburetor 4-stroke engine ROTAX 912 ULS2 with maximum takeoff power 73.5 kW (100 hp) at 5800 rpm (Fig. 7-14). Major accessories include gearbox, starter, dual capacitor discharge ignition, alternator, engine driven fuel pump and oil filter mounted on the left side of engine block.

Engine is attached to the airframe by means of a metal tube engine mount through the rubber engine mounts.

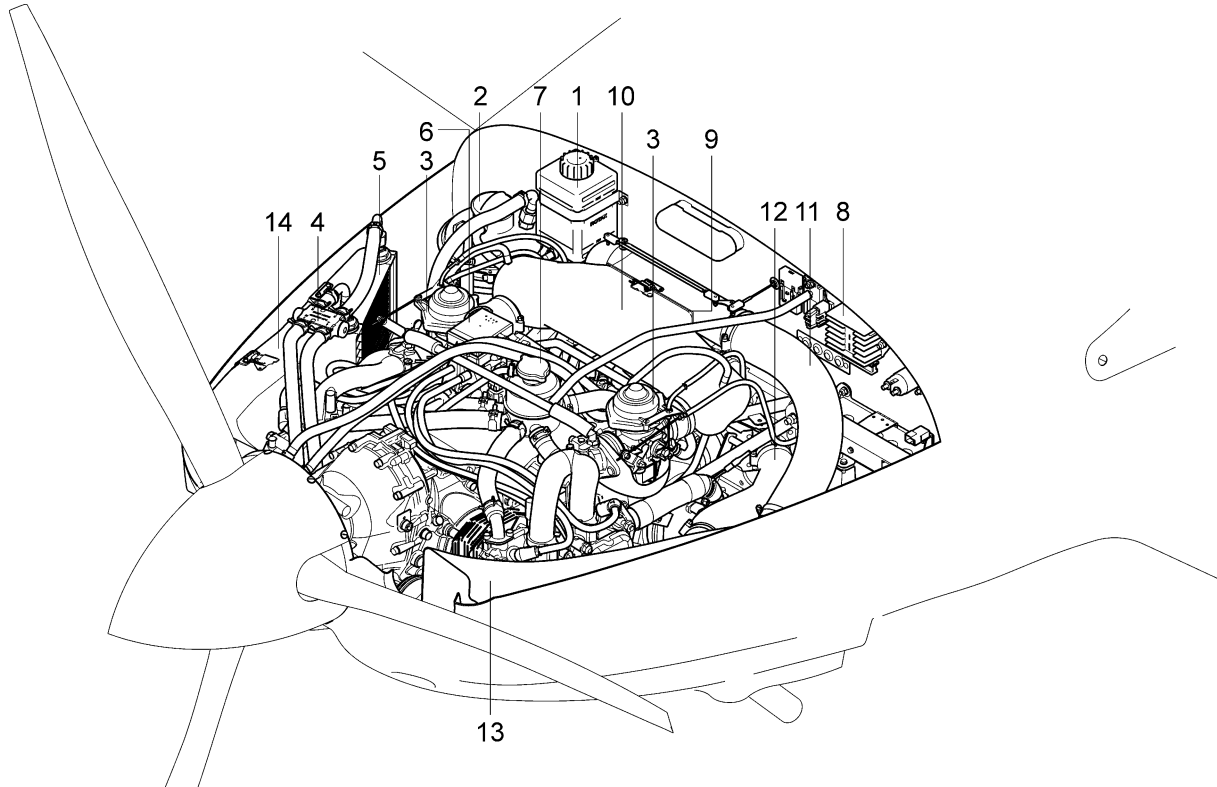

1.	Overflow bottle	8.	Regulator
2.	Oil tank	9.	Air filter
3.	Carburetor	10.	Airbox
4.	Oil thermostat	11.	Engine air intake hose
5.	Oil cooler	12.	Cabin venting air hose
6.	Ignition	13.	Ram air tunnel
7.	Expansion tank	14.	Oil cooler holder

Fig. 7-14 Engine installation components

#### WARNING

Never run the engine without propeller! This inevitably causes engine damage and is an explosion hazard!

#### NOTE

For more details refer to OPERATORS MANUAL FOR ROTAX ENGINE TYPE 912 SERIES, Doc. No. OM-912, latest edition.

### 7.14.1 Engine Controls

The throttle control labelled **THROTTLE** is a black knob installed in the center console (Fig. 7-15). It is configured so that the throttle is opened in the forward position and closed in the full aft position. Throttle control is operated by rotating the knob in clockwise direction for increase (A) or counter clockwise for decrease (B) of engine speed. For rapid or large adjustments the knob may be moved forward for increase (D) or backward for decrease (E) of engine speed by depressing the lock button (C) at the end of throttle control and then re-positioning the throttle control as desired.

Friction of the throttle control is adjusted by rotating the knob (F) on the bottom of the control handle clockwise for increase and counter clockwise for decrease of friction. The throttle control is mechanically linked by steel cables with the carburetors.

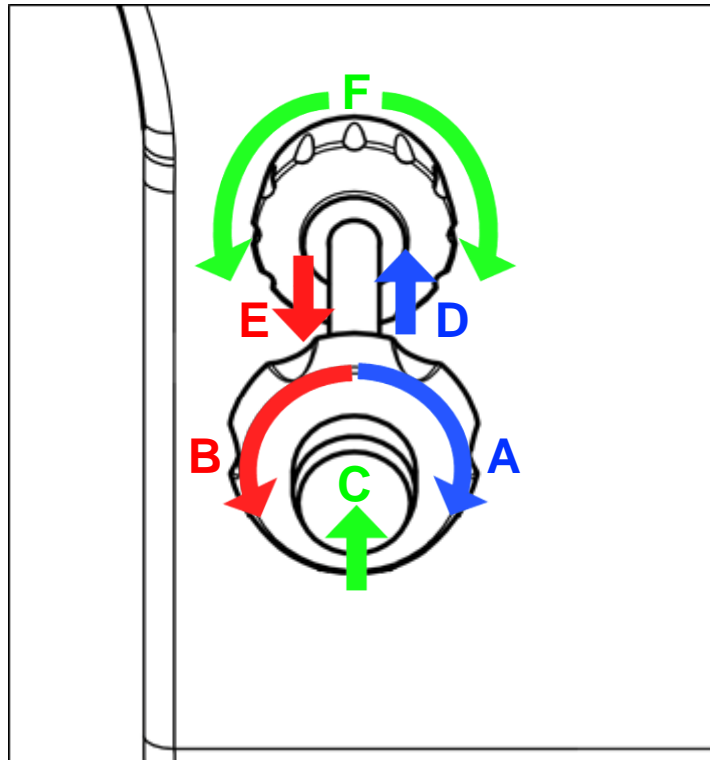

Fig. 7-15 Throttle controller

The choke control, labelled **CHOKE** is a grey round knob located in the center console. The mixture is enriched as the controller is pulled out. The richest mixture is set at the full aft position of the controller. The **CHOKE** may be used only on the ground and for cold engine start only.

### 7.14.2 Cooling System

The engine has both a water and an air cooling system.

The water cooling system consists of a water radiator installed in the lower engine cowling. The system is equipped with a water thermostat that keeps the coolant temperature in optimum range.

The air intakes to cool the engine compartment are located on the upper engine cowling and on the left side from spinner. Cooling air baffled in the engine compartment discharges under the aircraft.

#### WARNING

Never check the coolant level when the engine is hot! Always let the engine cool down to ambient temperature!

### 7.14.3 Exhaust System

Exhaust gases from each cylinder pass through the exhaust manifolds to a muffler that is attached to the engine mount. Exhaust gases exit through an exhaust pipe on the left side.

A shroud around the muffler forms a heating exchanger providing warm air for cabin heating.

### 7.14.4 Air Induction System

The engine air induction system receives air through an intake tunnel bonded to the left side of lower engine cowling. The air flows through an air hose to the air filter holder. There is a shroud on the muffler which preheats the air flowing to the air filter holder.

The air filter holder is equipped with a preheating system controlled by a yellow square control knob labelled **CARBUR. PREHEATING**. Warm intake air is adjusted at full aft position and the ambient temperature intake air is adjusted at full forward position of the carburetor preheating control. Depending on the carburetor preheating control setting, ram air and preheated air are mixed together and enter through the air filter to the airbox. The airbox is connected to both carburetors.

The use of carburetor preheating results in engine power and engine speed decrease. The temperature of air in the airbox is indicated by Dynon SkyView SV-D1000 (marked as AIRBOX). Carburetor preheating is used only in the case of carburetor or air filter icing.

#### NOTE

Using of carburetor preheating results in engine power and engine speed decrease.

### 7.14.5 Oil System

The engine is provided with a dry sump forced lubrication system with a main oil pump, integrated pressure regulator and oil pressure sensor. The oil pump draws the engine oil from the oil tank through the oil thermostat (low oil temperature) or also through oil cooler (high oil temperature). Oil cooler is attached in the ram air tunnel on the right side of lower engine cowling.

The oil pump forces the oil through the oil filter to the points of lubrication in the engine. The surplus oil emerging from the points of lubrication accumulates in the bottom of crankcase and is forced back to the oil tank by the piston blow-by gases. The oil pump is driven by the camshaft.

The oil temperature sensor for reading of the oil inlet temperature, and the oil pressure sensor are located on the oil pump housing.

The oil tank is attached to the firewall on the right side and oil level check is available through the cowl oil door in the upper engine cowling. The oil tank is vented and discharges under the aircraft.

### 7.14.6 Ignition and Starter System

The engine is equipped with dual ignition electronic modules, with an integrated AC generator. The ignition unit needs no external power supply. Two independent charging coils located on the generator stator supply one ignition circuit each. The energy is stored in capacitors of the electronic modules.

There are two spark plugs in each cylinder. Normal operation is conducted with both ignition circuits ON due to the more complete burning of the fuel/air mixture with dual ignition.

Ignition circuits are controlled by switches on the instrument panel labelled **IGNITION**. Starter is operated by a keyed ignition switch installed in the instrument panel. When the key is rotated to **START** position (with **MASTER SWITCH** in the ON position), the starter is energized and will crank the engine.

### 7.14.7 Engine Instruments

Aircraft is fitted with MFD Dynon SkyView SV-D1000 (RH display) which displays engine parameters listed below. MFD also display flight parameters listed in the Chapter 7.5.1. Exceeding any of the engine parameters (any parameter is in red range) is signaled by a warning lamp **EMS** on the instrument panel.

- Manifold pressure (MAP)
- Engine RPM (RPM)
- Exhaust gas temperature (EGT)
- Oil temperature (OIL °C)
- Oil pressure (OIL BAR)
- Coolant temperature (COOLNT °C)
- Airbox temperature (AIRBOX °C)
- Fuel pressure (FUEL BAR)
- Fuel flow (FLOW LTR/HR)
- Fuel level (LEFT LTR, RIGHT LTR)
- Voltage (BATT VOLTS)
- Current (AMPS AMPS)
- Ignition (MAG A, MAG B)
- Pitch and roll trim (TRIM)
- Other data: consumed fuel volume (LTRS USED), remaining flight time (TIME REM), actual operational range (RANGE), fuel volume at next way-point (WPT LTR)

#### NOTE

For more details refer to Dynon Avionics SkyView System Pilot's Guide, Document No. 101321-016 (revision Q or later).

As a standby are installed RPM indicator, fuel pressure indicator, engine hours counter and flight hours counter.

MFD displays the information in the following screen arrangements:

- EMS (Fig. 7-16)
- EMS / MAP (Fig. 7-17)
- EMS / EFIS with compass rose (Fig. 7-18)
- EMS / EFIS with g-load indication (Fig. 7-19)
- EMS / EFIS with analogue instruments design (Fig. 7-20)
- EMS / EFIS with compass rose / MAP (Fig. 7-21)
- EMS / EFIS with g-load indication / MAP (Fig. 7-22)
- EMS / EFIS with analogue instruments design / MAP (Fig. 7-23)

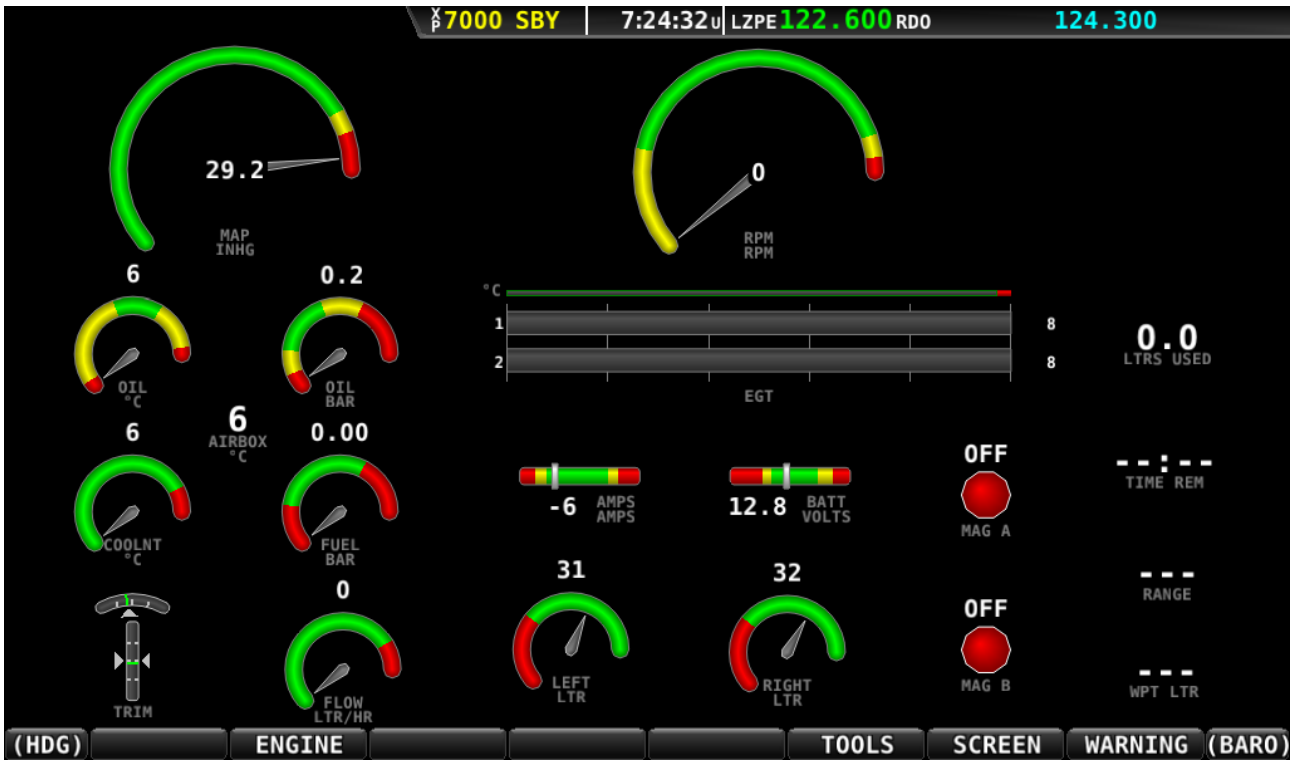

Fig. 7-16 Arrangement screen 1

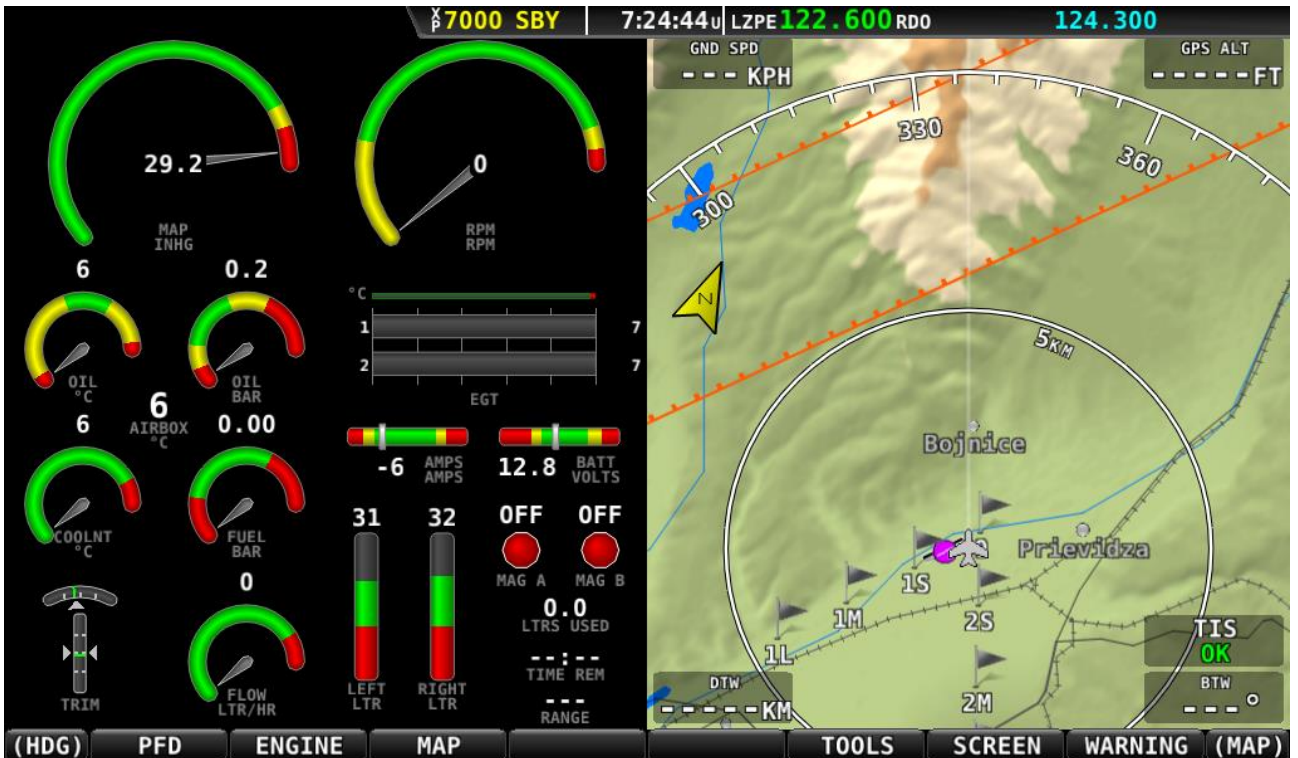

Fig. 7-17 Arrangement screen 2





Fig. 7-18 Arrangement screen 3



Fig. 7-19 Arrangement screen 4



Fig. 7-20 Arrangement screen 5



Fig. 7-21 Arrangement screen 6



Fig. 7-22 Arrangement screen 7



Fig. 7-23 Arrangement screen 8

## 7.15 Propeller

The aircraft is equipped with propeller EVRA PerformanceLine 175/xxx/805.5 is 3-bladed ground adjustable propeller with diameter 1.750 m (68.90 in). It has wooden core blades covered by glass fabric with stiffened leading edges. Blades are mounted in an aluminum hub. The propeller hub is attached to a flange and base plate and fixed to the engine's propeller flange. Composite spinner is fixed to the base plate.

**NOTE**

For more details refer to Aircraft Maintenance Manual  
AS-AMM-01-000, Chapter 61.

## 7.16 Fuel System

### 7.16.1 System Description

Fuel is supplied to the engine depending on the **FUEL** selector valve position (**LEFT** - **RIGHT** - **OFF**). To select the left tank rotate the knob to position "A" or to select the right tank rotate the knob to position "B". To shut off the fuel valve, lift the lock "D" and rotate the knob to position "C" (Fig. 7-24).

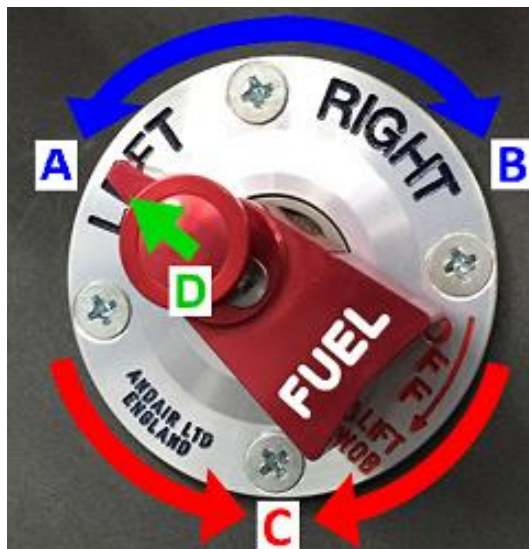

Fig. 7-24 Fuel selector

From both fuel tanks the fuel flows through the fuel strainers and fuel filters to the **FUEL** selector valve inlets. From the **FUEL** selector valve the fuel flows through the electric fuel pump (by-passed with check valve) to the engine driven fuel pump and then to a distributor inlet. One of distributor's outlets is connected to carburetors through the fuel flow meter sensor and 3-way distributor. Fuel flow meter measures only the fuel consumed by the engine. Second one is fitted with a restrictor jet to which a return line is connected. Return line leads back to the left fuel tank only.

Fuel pressure sensor and standby fuel pressure indicator are installed in the fuel system and connected through the 3-way distributor with restrictor jets in its outlets to the 4-way distributor. Both check the actual pressure in the fuel supply line. Fuel pressure data from sensor are processed and displayed by Dynon SkyView SV-D1000.

The wing fuel tanks are connected with the fuselage wing tanks using a simple hose connection with clamps. Fuel tanks are vented from the highest point and discharge through hoses protruding under the aircraft through the fuselage skin inside of the center tunnel.

Fuel system diagram is shown at Fig. 7-25.

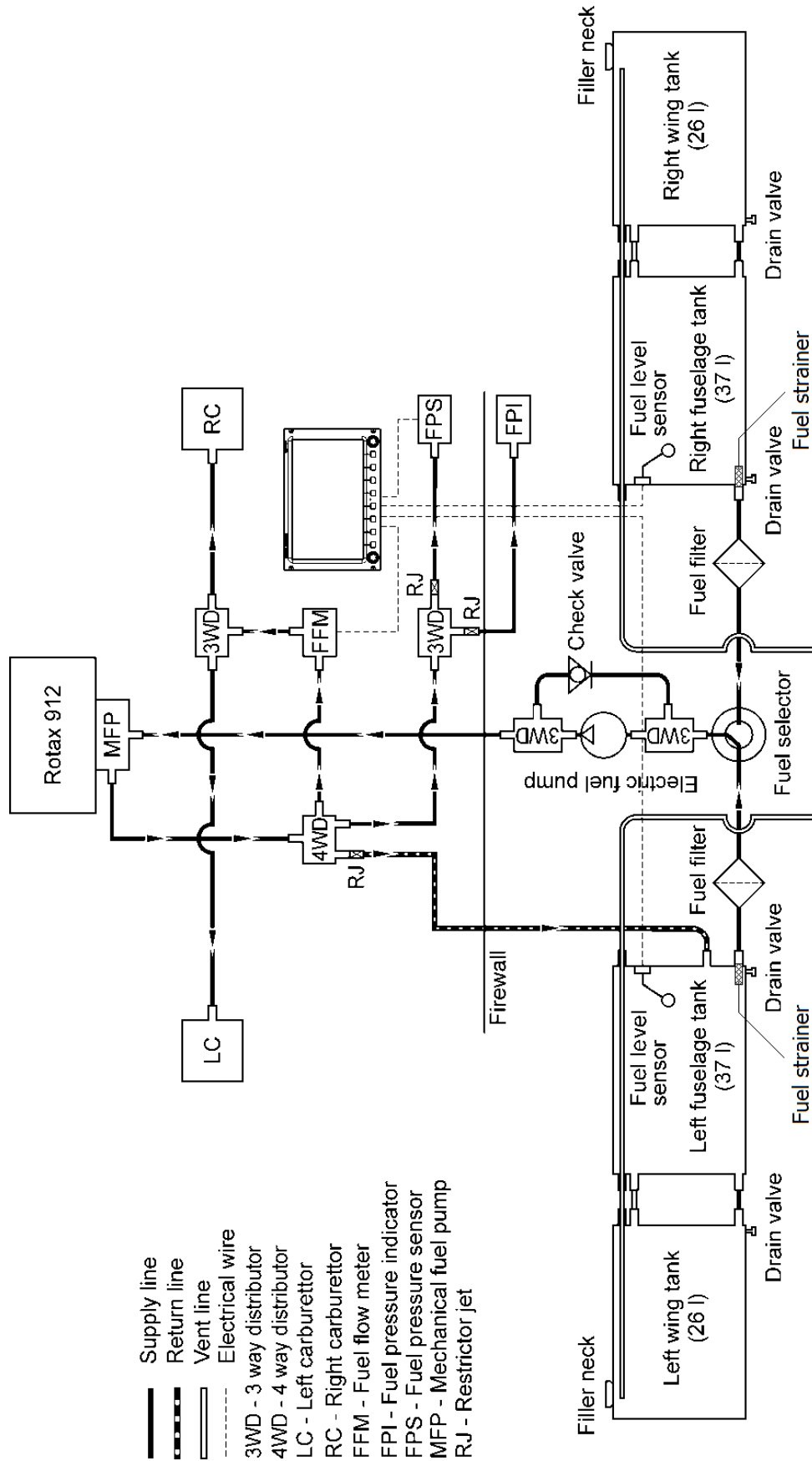

Fig. 7-25 Fuel system diagram

### 7.16.2 Fuel Management

The return line directs fuel to the left fuel tank only. The left tank must be used for all takeoffs and initial flight when it is more than ½ of fuel to avoid it overflowing. Therefore, use the left tank until 1/2 of its capacity is consumed before changing to the right tank. This procedure makes enough space in the left tank for returning fuel.

For maximum fuel utilization, when **LH FUEL RES.** / **RH FUEL RES.** warning lamps illuminate, switch to the right tank and consume all available fuel. In horizontal flight it is possible to consume almost all the fuel in the tank. After the right fuel tank is empty, switch to the left tank.

#### CAUTION

Unconsumed fuel is returned to the left fuel tank only. Monitor the fuel levels in the tanks during flight to avoid venting it overboard!

#### NOTE

If the left tank is full, it must be selected for all takeoffs and initial flight until 1/2 of its capacity is consumed before changing to the right tank.

### 7.16.3 Fuel Measurement System

The fuel quantity in liters is displayed by Dynon SkyView SV-D1000. There is a fuel float type of fuel level sensor in the both left and right fuel tank. Fuel level sensor is installed in the root rib of fuselage fuel tanks.

Due to the fuel tank geometry and position of fuel level sensor, it is possible to indicate the fuel quantity only in the range 0 - 45 l. If the fuel quantity in the tank is above 45 l, Dynon SkyView SV-D1000 displays "45+". Determining of fuel quantity in the tank above 45 l is possible only on the ground by using a dipstick (Fig. 7-26).

The fuel level sensors are calibrated in the aircraft's level position to indicate the correct fuel quantity during horizontal flight. The dipstick is calibrated in the aircraft's parking position on a level surface to indicate the correct fuel quantity in the tank above 45 l during refueling.

**LH FUEL RES.** / **RH FUEL RES.** warning lamp illuminates when the fuel quantity goes below 16 liters / 4.23 U. S. gal in each tank (aircraft in level flight). The fuel in each tank is sufficient for half-hour flight at maximum continuous power.

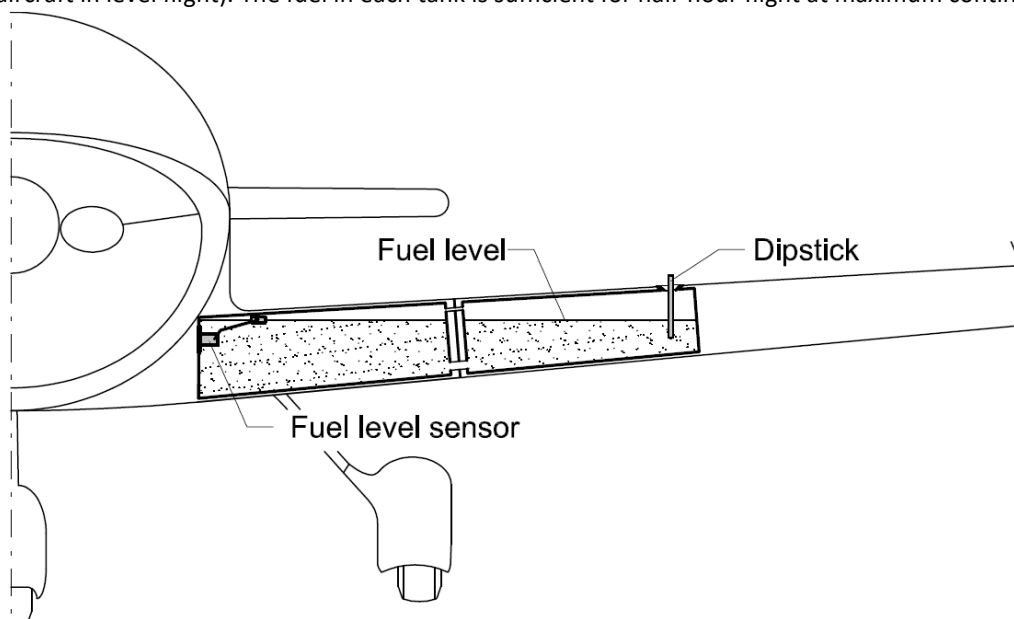

Fig. 7-26 Fuel quantity measurement

Dynon SkyView SV-D1000 has a fuel computer function. To obtain accurate data, the fuel computer must be reset every time when the fuel has been added to the aircraft. Fuel computer adjustments are made under the EMS > FUEL menu. When the FUEL is pressed, the window Fig. 7-27 is displayed. In addition, the fuel computer is configured to detect when the fuel has been added while SkyView was off, as would be the case during normal refueling operation (Auto Fuel Detect). SkyView will automatically display the fuel menu upon startup as a reminder to adjust the fuel computer.

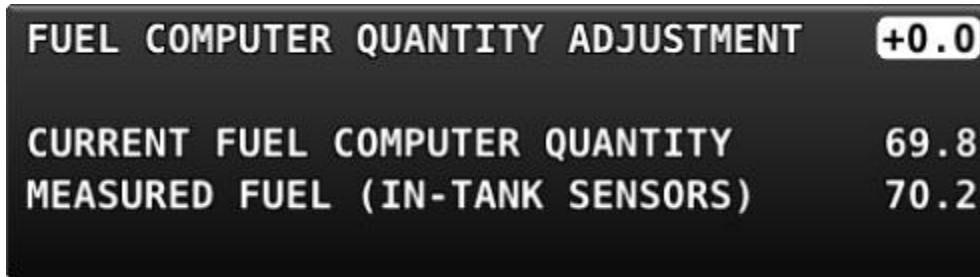

Fig. 7-27 Fuel computer window

**FUEL COMPUTER QUANTITY ADJUSTMENT** – displays the quantity of fuel that the fuel computer will add/subtract from the previous total fuel state.

**CURRENT FUEL COMPUTER QUANTITY** – is the total amount of fuel on board. This is the number that ultimately needs to be correct in order for the fuel computer to accurately perform its calculations.

**MEASURED FUEL (IN-TANK SENSORS)** – is the amount of fuel measured by the fuel level sensors. Fuel level sensor indicates the fuel amount in the tank only up to 45 l and is calibrated to show the correct amount when the aircraft is level. The aircraft on the ground is in a slightly tail down position, therefore the TOTAL FUEL and MEASURED FUEL may differ from each other.

There are a few different ways to adjust the fuel computer's fuel state:

- While FUEL menu is displayed, turn the FUEL knob to add or subtract fuel. This is limited to adjustments that set the Total Fuel to between 0 and the total fuel capacity as defined in the Setup Menu.
- Press FULL to have SkyView recall a previously programmed amount of fuel which represents the full fuel load of the aircraft. SkyView FULL is set to 126 l.
- Press PRESET to have SkyView recall a previously programmed amount of fuel which represents different fuel loading besides "full". This is commonly used in aircraft that have visual tabs in the tanks to easily fill to a non-full but well-defined fuel state. SkyView PRESET is set to 40 l.
- Press MATCH to have SkyView automatically add/subtract the appropriate amount of fuel so that Total Fuel matches the Measured Fuel value that the physical fuel tank sensors are measuring. Press ACCEPT to confirm the new displayed Total Fuel and exits the FUEL menu.
- Press CANCEL to discard any changes made to the Total Fuel and exits the FUEL menu.

Dynon SkyView SV-D1000 fuel computer displays following information (see the screens in the Chapter 7.14.7):

The consumed fuel marked "**LTRS USED**" is calculated based upon measured flow rates and user input of fuel quantity. It resets itself when the unit detects that oil pressure has exceeded 15 PSI for the first time after being powered on. This allows you to view the fuel used value from your last flight before engine start.

The time remaining info item marked "**TIME REM**" displays how much time is estimated remaining before the aircraft is out of fuel.

The fuel range info item marked "**RANGE**" displays the distance the aircraft can travel at its current GPS ground speed before it is out of fuel.

The fuel at waypoint info item marked "**WPT LTR**" displays how much fuel will remain at the next waypoint. This info item uses the current HIS nav source for waypoint information, and only displays information when there is a waypoint being navigated to. It assumes you are flying directly at the waypoint and does not adjust for non-direct flights.



### 7.17 Brake System

The main wheels have hydraulically operated single-disc type brakes. The brakes also function as parking brake.

Brake system consists of a brake lever, master cylinder, brake fluid reservoir, brake pressure limiter and calipers. Braking pressure is initiated by pulling the brake lever backward which distributes to both calipers.

The brake lever protrudes from the pedestal panel and moves in the slotted link with two positions labelled **PARK** and **MAX**. To apply the brakes, pull the brake lever backward as required.

When parking the aircraft set the brake lever to position **PARK**. When the maximum brake action is required, set the brake lever to position **MAX**.

A brake system malfunction or the onset of brake failure may be indicated by a gradual decrease of brake action, noisy or dragging brakes, soft, spongy or excessive travel of the brake lever and weak braking action. When these symptoms are observed, immediate maintenance is required. If the brakes are soft or spongy or brake lever travel increases, pumping the brake lever may build braking pressure.

#### **WARNING**

Never operate the brake lever in-flight!

#### **WARNING**

Do not simultaneously increase power and apply brakes during taxiing!

### 7.18 Electric System

The aircraft has 12 V DC system. Installation is dual-wire type.

Board network is supplied by maintenance free accumulator 12 V that is installed on firewall in the engine compartment. Network is supplied with AC generator with external rectifier regulator (12 V DC).

Circuit breakers are located at the lower and right area of instrument panel's right side.

Dual contactless ignition of the engine is a separate part of electrical installation. Each ignition circuit can be switched ON/OFF independently using corresponding switches labelled **IGNITION**.

Keyed ignition switch is connected to the accumulator through the master switch labelled **MASTER SWITCH**. It has positions **OFF - INST. - CHARGE - START**. In the **OFF** position, the starter is electrically isolated. In the **INST.** position are energized single value instruments (standby RPM indicator, engine hours and flight hours) and fuel pump. In the **CHARGE** position also a warning lamp **CHARGE** is energized and indicates the charging status. In the **START** position, the starter is energized and will automatically return to the position **CHARGE** when released. Before repeated engine starting, it is necessary to turn the keyed ignition switch to **OFF** position first, and then to position **START**.

PFD and MFD Dynon SkyView SV-D1000 are connected through a circuit breaker directly to the **MASTER SWITCH**.

Avionics (RDST, XPDR, intercom and traffic sensor) are connected through separate circuit breakers **COMM, NAV, XPDR, INTERCOM** and **TIS** the avionic relay. Avionic relay is activated by separate switch **AVIONICS** and is protected by circuit breaker **AVIONICS** that is connected to the **MASTER SWITCH**.

Navigation and anti-collision lights are activated by a switch labelled **NAV / ACL** and are connected through a circuit breaker to the **MASTER SWITCH**. Landing lights are activated by a switch labelled **LAND** and are connected through a circuit breaker to the **MASTER SWITCH**.

Fuel pump is activated by a separate switch labelled **FUEL PUMP** and is connected through a circuit breaker to the **INST.** position of keyed ignition switch.

Stall warning system consists of stick shaker handle, buzzer and warning lamp that are triggered by ACI Stall Warner (AoA flap) and Stall Warning Transducer (only buzzer and warning lamp). Stall warning system is connected through a circuit breaker to the **MASTER SWITCH**.

Function of warning lamps, control lamps, stick shaker and stall warning horn can be verified by pressing button labelled **TEST**.

12 V / 10 A sockets of an automotive type are installed at both lower corners of the instrument panel and are connected through a circuit breaker to the **MASTER SWITCH**.

Engine hours and flight hours are power supplied through a circuit breaker from the **INST.** position of keyed ignition switch.

ELT has its own battery for power supply.

Switch is ON with a lever switched UP and OFF with a lever switched DOWN (Fig. 7-28).

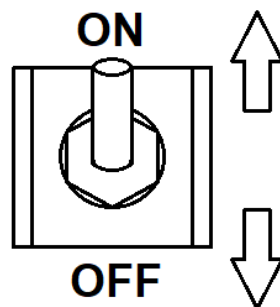

Fig. 7-28 Switch ON / OFF position

## 7.19 Cabin Heating and Ventilation

Cabin heating and ventilation supply conditioned air for cabin heating/venting and windshield demist.

Cabin heating and venting air is provided by a control box and enters the cabin through the firewall. The air is received from the deflector installed behind the water radiator and flows through the air hose to the heat exchanger on the muffler to be heated. Heated air from the exchanger flows through the air hose to the control box. Fresh air is received from the ram air tunnel installed on the left side of lower engine cowling and is directed through the air hose to the control box.

The proportion of heated to fresh air is controllable by means of controllers labelled **CABIN HEATING** and **CABIN VENTILATION** (Fig. 7-4). The means of control is as follows: PULL to OPEN, PUSH to CLOSE.

There are venting windows on the both sides of windshield (Fig. 7-29).

Fresh air for cabin venting and windshield demist is received from the NACA intakes on both sides of the canopy. The fresh air flows through the canopy frame and enters the cockpit through the air outlets on both sides of the canopy. The air outlets control the amount and direction of air (Fig. 7-30).

The fresh air for windshield demisting flows through the holes located in the front section of canopy frame. The amount of air is controlled by knobs on both sides of canopy (Fig. 7-31).

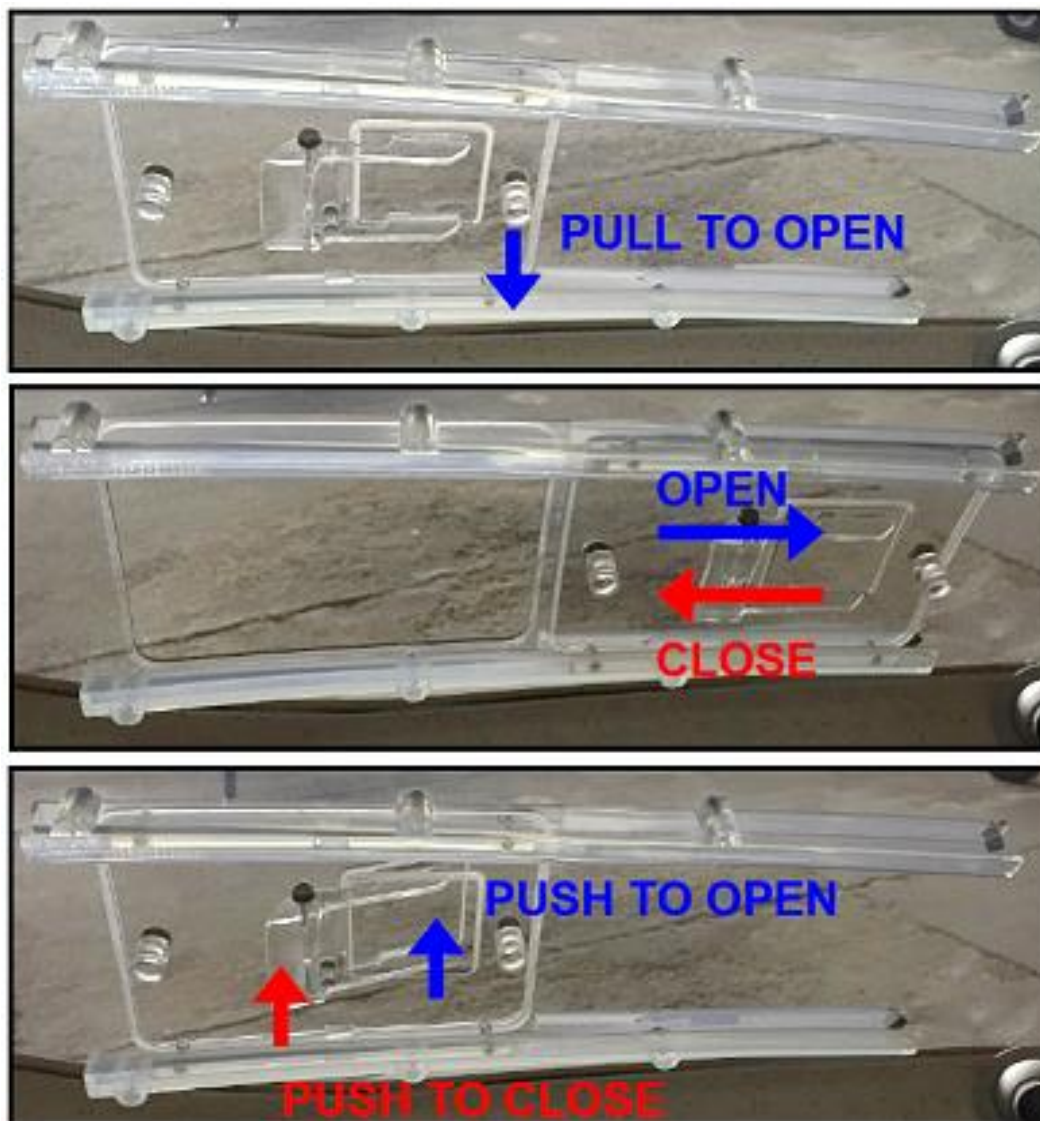

Fig. 7-29 Venting windows



Fig. 7-30 Air outlets for cockpit venting

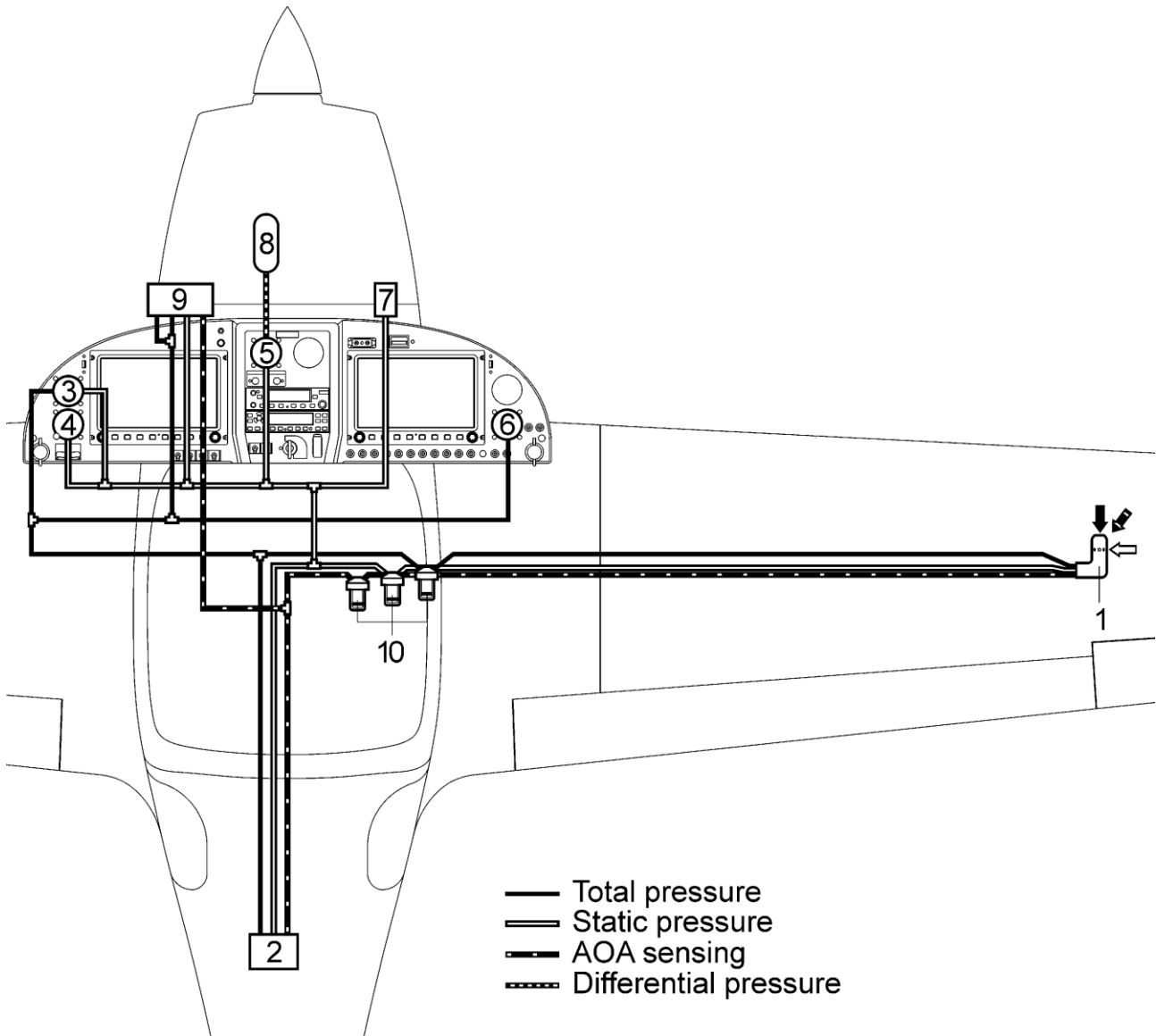

Fig. 7-31 Windshield demist knob

### 7.20 Pitot-Static System

The pitot-static system consists of a single pitot probe located under the right wing. The pitot probe includes total pressure, static pressure and AoA ports. In each line a drain sump is installed under the co-pilot seat to trap water and moisture that enters the system. The drain sumps should be checked at the annual inspection or in any case when water in the system is known or suspected.

Pressure distribution to individual instruments in the cockpit is done through flexible plastic hoses (Fig. 7-32).



1.	Pitot probe	6.	Flight hours counter
2.	ADAHRS module	7.	Altitude encoder
3.	Standby airspeed indicator	8.	Expansion bottle
4.	Standby altimeter	9.	Stall warning transducer
5.	Standby vertical speed indicator	10.	Drain sumps

Fig. 7-32 Pitot-static system schematic

## 7.21 Stall Warning System

The Stall Warning System of WT9 Dynamic LSA consists of two independent stall warning sensors. The first sensor is the Stall Warning Port (AoA port) located on the pitot probe under the right wing. The second sensor is ACI Warner (AoA flap) installed on the left wing leading edge (Fig. 7-33).

The stall warning system starts the warning within the range 9-19 km/h (5-10 kts) before stalling in wing level flight and at slightly greater margins in turning and accelerated flight.

In some emergencies when the **MASTER SWITCH** has to be set OFF, only the stall warning of Dynon SkyView D1000 system will be available (visual indication on EFIS screen and headset sound).

Stall warning system has following indication of imminent stall:

- Visual Indication
  - Indicator on the EFIS screen (Dynon SkyView D1000)
  - **STALL** warning lamp on the instrument panel
- Aural Indication
  - Headset sound (Dynon SkyView D1000)
  - Buzzer
- Control Stick Shaker
  - Motor with the eccentric mass installed in the pilot control stick handle

To perform a ground test of the stall warning system, the aircraft is equipped with a **TEST** button. The **TEST** button activates:

- **STALL** warning lamp on the instrument panel
- Buzzer
- Control stick shaker
- All warning/check lamps

### WARNING

If the **MASTER SWITCH** is OFF, the stick shaker, buzzer, and warning lamp are out of action!

### WARNING

The stick shaker is installed only on the pilot side!

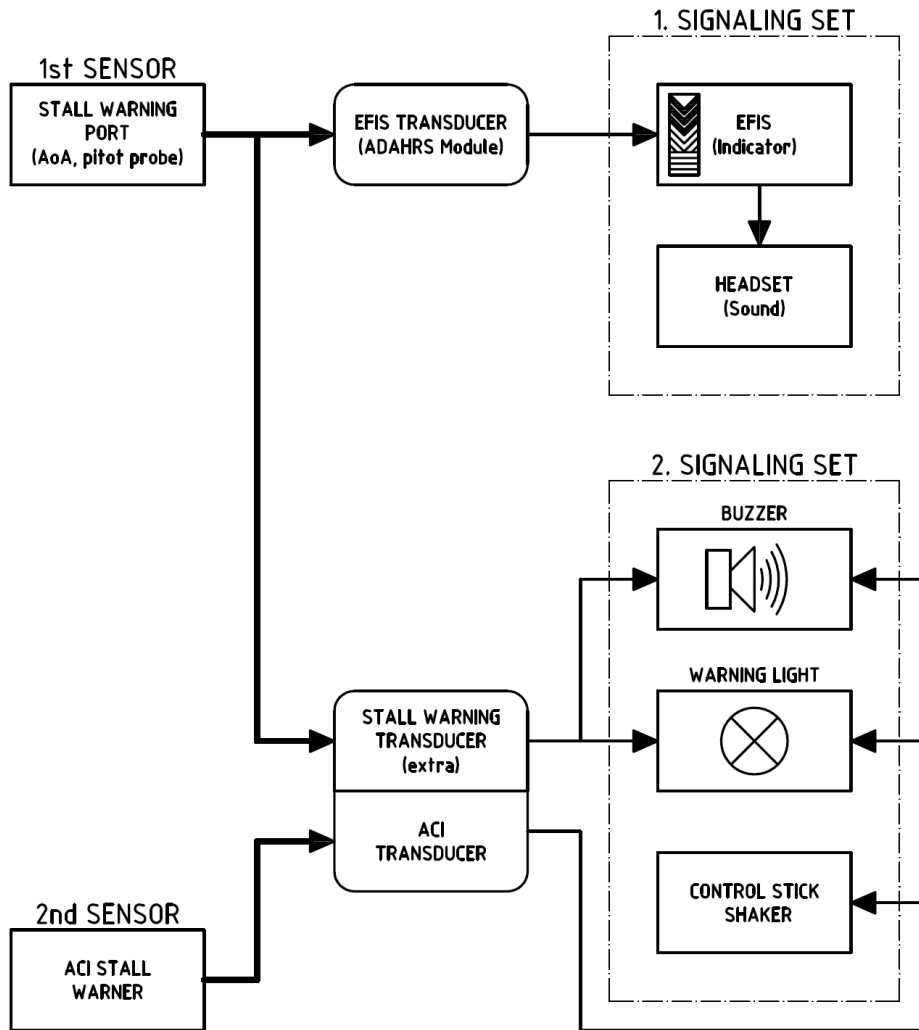

Fig. 7-33 Stall warning system schematic

### 7.22 Emergency Parachute System

The aircraft is equipped with the emergency parachute system MAGNUM 601 S-LSA. The emergency parachute system (EPS) is intended to save lives of occupants, but the activation of the system will most likely destroy the aircraft. In adverse circumstances, the activation may cause serious injury or death to the occupants. It is important to read carefully the EPS system description in this chapter and Chapter 3 - EMERGENCY PROCEDURES.

The EPS consists of a parachute, extraction device (rocket), activation handle and harnesses that are attached to the fuselage structure.

A textile container with a parachute is attached to the board behind the instrument panel. The parachute is connected to the fuselage structure by means of two main straps and one stabilizing strap. The main straps are fixed to the attachment points on the firewall. The stabilizing strap that consists of steel rope is imbedded in the fuselage shell and attached to the auxiliary spar of the fuselage. When the parachute deploys, the steel rope is pulled out from the fuselage skin.

A weakened composite cover to enable rocket's smooth egress and parachute extraction closes the opening in the fuselage.

The rocket is attached to the firewall and it is connected to an actuator installed in the center console accessible for both pilot and co-pilot. The actuator is labelled **RESCUE SYSTEM**. The lock securing the actuator has to be removed before flight. Even after the lock is removed, the actuator protector secures the actuator from unintentional activation of rescue system (Fig. 7-34).

Before activation, if possible, minimize the flight speed. If time permits, stop the engine to prevent the straps from getting to the propeller.

Activation of EPS is performed by opening the rescue system actuator protector (I.) and pulling the actuator (II.) (Fig. 7-34). Pull the actuator straight backward with a strong, steady and continuous force until the rocket activates. Up to 12 kg / 26.5 lb force or greater may be required to activate the rocket.

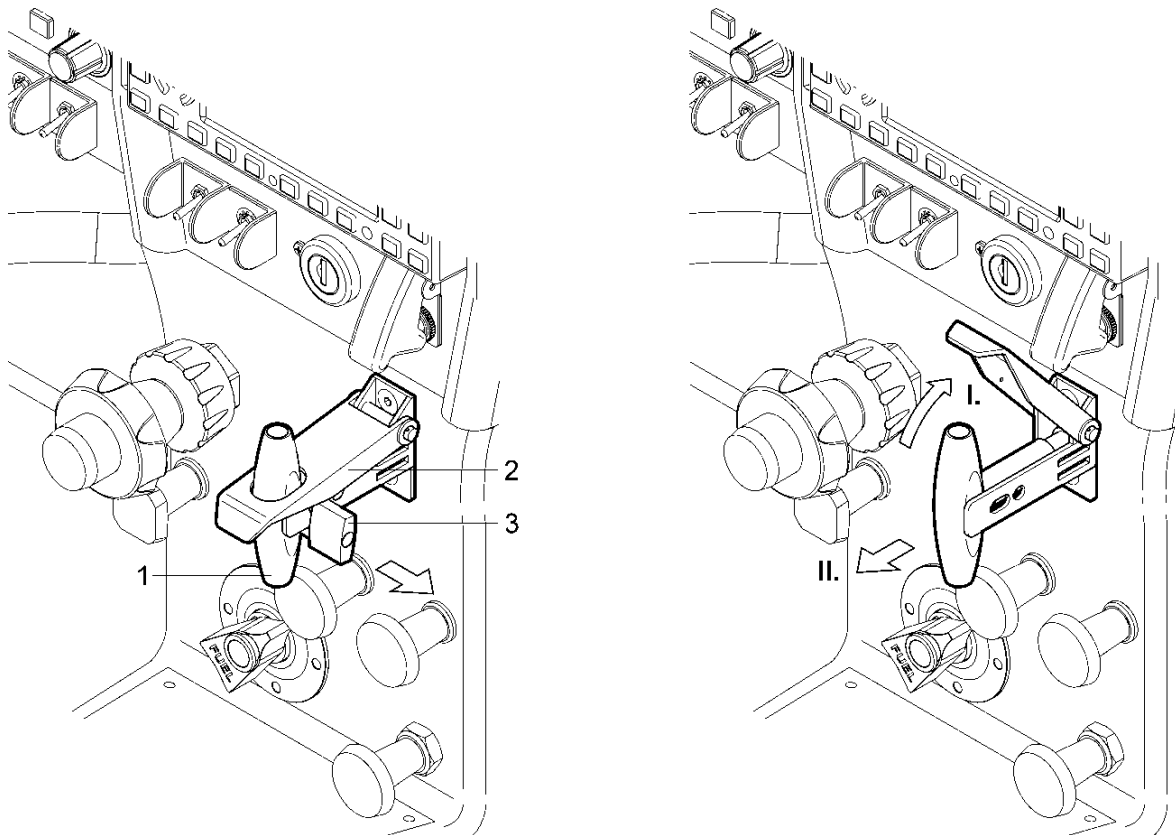

1.	<b>RESCUE SYSTEM</b> actuator	3.	Lock
2.	<b>RESCUE SYSTEM</b> actuator protector	-	-

Fig. 7-34 Activating of EPS



After activation of EPS the rocket ignites, egresses the fuselage and pulls out the parachute that starts to inflate. The aircraft begins to decelerate and there is a gentle jerk as the parachute is fully inflated. The parachute is equipped with a slider to soften the loading that may momentarily reach the peak value 5g. The aircraft may swing but with a stabilizing tendency. The exact sequence depends on the situation, circumstances of the activation, position and the altitude. Activation at higher altitude will give more time to stabilize from the swinging. The length of straps is designed so that the aircraft descends in the landing gear down position with tail and left wing slightly sloped down. Descent rate at maximum weight is expected to be maximum 1400 fpm (7 m/s).

After landing, leave the aircraft as quickly as possible. In windy weather an inflated parachute may drag the aircraft. By pulling several parachute lines that are beside one another, the parachute will become empty and minimize the dragging. After landing on water exit the aircraft promptly prior to its sinking. There is a danger of entangling yourself in the parachute.

### WARNING

Remove the actuator lock before flight!

### WARNING

The rocket force is used as an extraction device! The EPS does not require electrical power for activation! Stay clear of parachute egress point when the aircraft is occupied!

### CAUTION

Ground impact is expected to be equivalent to touchdown from a height of approximately 8.2-9.8 ft (2.5-3.0 m)! Occupants must prepare for it in accordance with the EPS deployment procedure in Chapter 3 - EMERGENCY PROCEDURES!

### NOTE

For more details refer to "MANUAL FOR MOUNTING AND USE OF RESCUE BALLISTIC PARACHUTE SYSTEMS SERIES MAGNUM", latest edition.

### NOTE

EPS is designed to work in a variety of aircraft attitudes. However, deployment in an attitude other than level flight may yield deployment characteristics other than described above.



## WT9 Dynamic LSA / Club

### Pilot's Operating Handbook

AS-POH-01-000

---

This page is left blank intentionally

# 8 HANDLING AND SERVICING

## TABLE OF CONTENTS

<b>8.1</b>	<b>INTRODUCTION .....</b>	<b>8-2</b>
<b>8.2</b>	<b>GROUND HANDLING .....</b>	<b>8-3</b>
8.2.1	Towing .....	8-3
8.2.2	Parking.....	8-4
8.2.3	Tie-Down Instructions .....	8-5
8.2.4	Jacking and Leveling .....	8-6
<b>8.3</b>	<b>SERVICING OF OPERATING FLUIDS .....</b>	<b>8-7</b>
8.3.1	Fuel Servicing .....	8-7
8.3.2	Fuel Contamination and Sampling .....	8-9
8.3.3	Oil Servicing.....	8-11
8.3.4	Coolant Servicing.....	8-13
8.3.5	Brake Fluid Servicing .....	8-13
<b>8.4</b>	<b>TIRE INFLATING .....</b>	<b>8-14</b>
<b>8.5</b>	<b>CLEANING AND CARE .....</b>	<b>8-15</b>
<b>8.6</b>	<b>WINTER OPERATION .....</b>	<b>8-18</b>

### 8.1 Introduction

This Chapter contains factory recommended procedures for proper ground handling and servicing of the WT9 Dynamic LSA / Club.

In order to ensure continued safe and efficient operation, keep in contact with your local dealer or aircraft manufacturer to obtain the latest information pertaining to your aircraft.

The following service publications are available to be obtained from the aircraft manufacturer of WT9 Dynamic LSA:

- Pilot's Operating Handbook (POH) – Pilot's Operating Handbook is structured into chapters as specified by CS-LSA. A current copy of the POH is provided at delivery.
- Aircraft Maintenance Manual (AMM) – Aircraft Maintenance Manual is divided into chapters as specified by ATA. A current copy of the AMM is provided at delivery.
- Service Bulletins (SB) – Pay special importance to the Service Bulletins. When you receive a Service Bulletin, comply with it as stated in the Service Bulletin. Service bulletins are updated and available on the manufacturer's website ([www.aerospool.sk](http://www.aerospool.sk)).

WT9 Dynamic LSA publications may be obtained by contacting customer service of aircraft manufacturer as follows:

Aerospool spol. s r. o.

Letisková 10

971 03 Prievidza

Slovak republic

Web: [www.aerospool.sk](http://www.aerospool.sk)

E-mail: [airworthiness@aerospool.sk](mailto:airworthiness@aerospool.sk)

In the correspondence regarding the aircraft include the aircraft serial number for accurate processing of your documentation needs.

## 8.2 Ground Handling

The aircraft can suffer higher stress loads on the ground than in the air. Do not push the aircraft on the ground by leaning on the control surfaces or the wing tips. Extreme caution must be taken when taxiing on rough or uneven ground because it could damage the integrity of the aircraft.

### CAUTION

Do not move the aircraft by pushing on control surfaces or the wing tips because applied pressure on the surface can create depressions which weaken the sandwich shell!

### 8.2.1 Towing

The aircraft is most easily towed and safely maneuvered on the ground by using a tow bar. The tow bar is engaged to the nose leg by means of a pin.

It is also possible to tow the aircraft by holding the propeller blades at the blade root. Before towing check if the space around the aircraft is clear of obstacles and people, and nobody is in the cockpit.

### WARNING

Remove the tow bar before starting the engine!

### WARNING

**MASTER SWITCH** and **IGNITION** must be switched OFF!  
Nobody is allowed to be in the cockpit!

### CAUTION

Push or pull the aircraft from the propeller blade root only, never at the wing tips or the control surfaces!

### CAUTION

Do not tow the aircraft with the canopy open!

a.	Wing flaps	Check <b>FLAPS 0</b>
b.	<b>MASTER SWITCH</b>	Check OFF
c.	<b>IGNITION</b>	Check OFF both circuits
d.	Brake	Check <b>PARK</b>
e.	Tow bar	Engage to nose leg by means of pin
f.	Brake	Release
g.	Aircraft	Move to desired locations
h.	Brake	<b>PARK</b>
i.	Tow bar	Remove

### 8.2.2 Parking

It is advisable to park the aircraft inside a hangar or eventually inside a weather-proof space with stable temperature, good ventilation, low humidity and a dust-free environment. The parking place should be protected against possible damage caused by sun radiation, humidity and wind. Sunbeams reflected through the canopy can generate spot heating and damage the cockpit area and the upholstery (Fig. 8-1).

For short term parking, the aircraft must be orientated in headwind direction, the parking brake must be engaged, the wing flaps must be in the retracted position, pitch trim fully forward and the wheels must be chocked.

For extended and unattended parking, as well as in unpredictable wind conditions, in areas where a danger of propwash from another aircraft or helicopter is present, the aircraft must be tied down to the ground or placed in a hangar.

For parking, head the aircraft into the wind if possible.

**WARNING**

Parking the aircraft with canopy open and tail directed towards the sun can cause damage in the cockpit area!

a.	Wing flaps	Check <b>FLAPS 0</b>
b.	<b>MASTER SWITCH</b>	ON
c.	<b>PITCH</b> trim	Fully forward
d.	<b>MASTER SWITCH</b>	OFF
e.	<b>IGNITION</b>	Check OFF both circuits
f.	Brake	<b>PARK</b>
g.	Canopy	Close, lock and cover with the cloth dust-cover, as necessary
h.	Tie-down	As required (see Chapter 8.2.3)

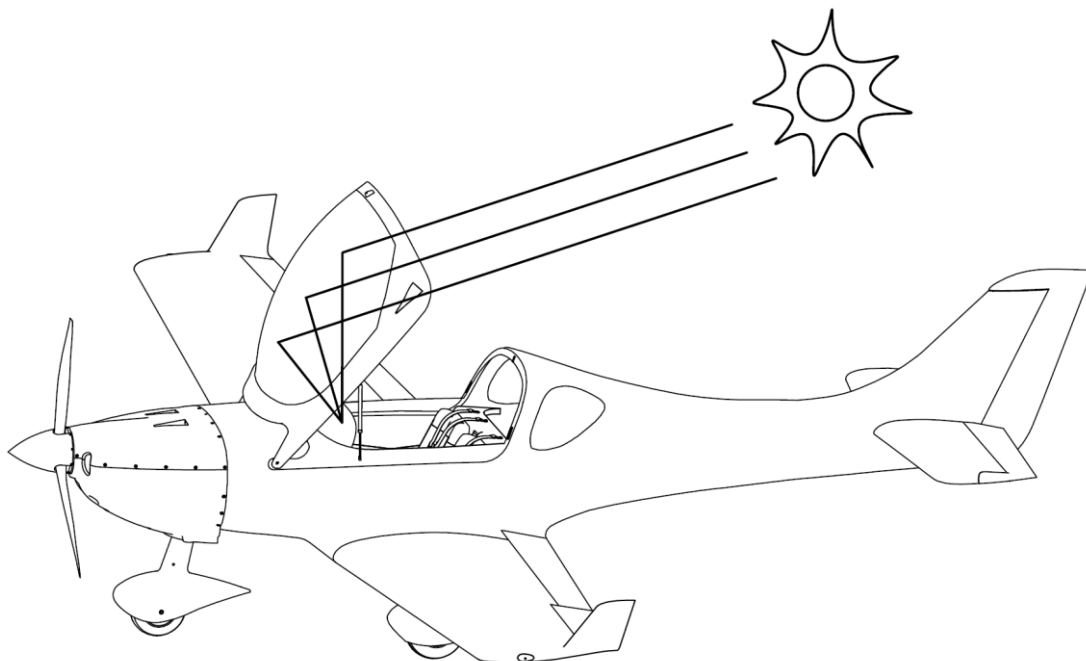

Fig. 8-1 Canopy sunbeams reflection

### 8.2.3 Tie-Down Instructions

Proper tie-down procedure is the best precaution against damage to a parked aircraft by gusts, strong winds or in areas where a danger of propwash from another aircraft or helicopter is present (Fig. 8-2). To securely tie-down the aircraft, proceed as follows:

a.	Wing flaps	Check <b>FLAPS 0</b>
b.	<b>MASTER SWITCH</b>	ON
c.	<b>PITCH</b> trim	Fully forward
d.	<b>MASTER SWITCH</b>	OFF
e.	<b>IGNITION</b>	Check OFF both circuits
f.	Brake	Check <b>PARK</b>
g.	Wheel chocks	Put the chocks (1) in front of and behind the main wheels
h.	Mooring eyes	Screw mooring eyes (2) into the left and right lower wing surface (near inspection hole)
i.	Aircraft	Tie-down to the ground through the mooring eyes (2) using ropes or chains
j.	Ailerons	Put into neutral position and lock them using an adhesive tape
k.	Fuel tank caps	Protect from water accumulation around the caps using adhesive tape
l.	Pitot probe	Install cover (3)
m.	Canopy	Close the sliding windows; close and lock the canopy and cover using textile canopy cover

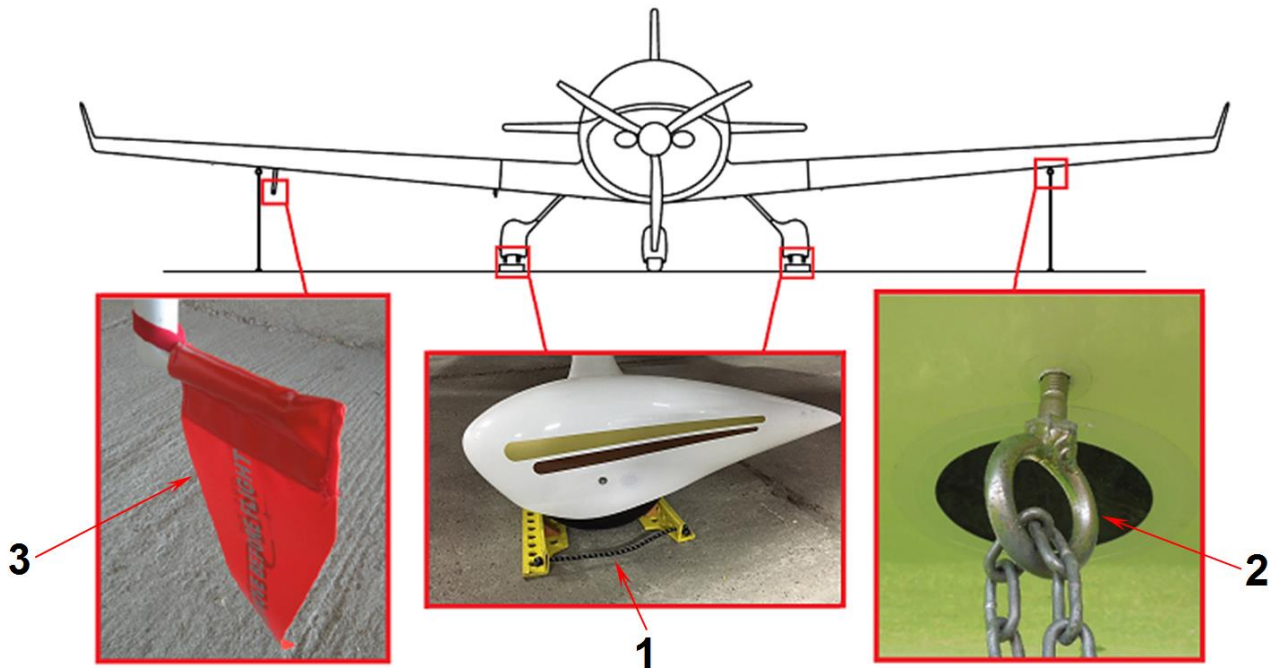

Fig. 8-2 Tied-down aircraft

### 8.2.4 Jacking and Leveling

The aircraft can be jacked and leveled using three jacks (1) at the jack points located on the bottom side of the fuselage. One jack point is located in the front section under the firewall and two jack points are located in the wing center section under the auxiliary spar. Each jack point is labelled **LIFT HERE**.

To prevent the aircraft from upset, install the tail stand (2) under the aircraft's tail (Fig. 8-3).

**WARNING**

**MASTER SWITCH and IGNITION must be switched OFF!**

Nobody is allowed to be in the cockpit!

#### Aircraft jacking:

a.	<b>MASTER SWITCH</b>	Check OFF
b.	<b>IGNITION</b>	Check OFF both circuits
c.	Brake	Check <b>PARK</b>
d.	Aircraft	Position on a hard, flat and level surface
e.	Jacks	Position the jacks (1) under the jack points and raise the jacks to firmly contact the jack points
		Raise the aircraft keeping the aircraft as level as possible
f.	Tail stand	Position the tail stand (2) under the tail and secure the aircraft

#### Aircraft lowering:

a.	Tail stand	Remove
b.	Jacks	Release the jacks as simultaneously as necessary to keep aircraft as level as possible and remove

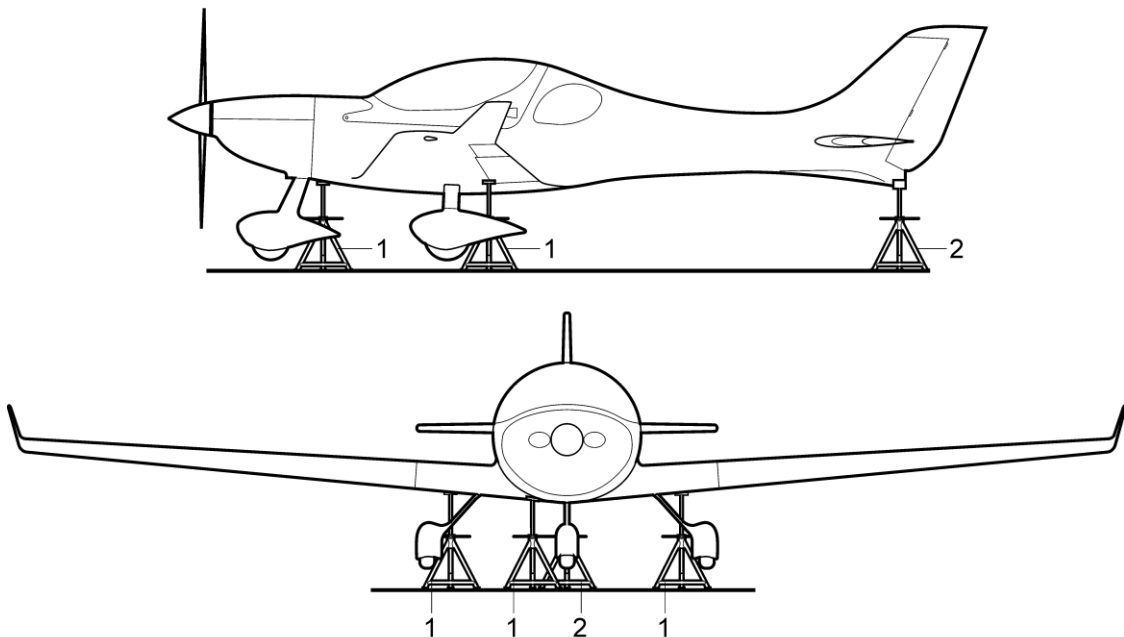

1. Jack	2. Tail stand
---------	---------------

Fig. 8-3 Jacking



### 8.3 Servicing of Operating Fluids

#### 8.3.1 Fuel Servicing

Observe all safety precautions required when handling gasoline. Filler necks are located on the upper surface of wings (Fig. 8-4). Fill up only with suitable fuel according to specification in Chapter 2.9.1.

Keep in mind maximum permitted takeoff weight and CG position when refueling the aircraft. The fuel should be distributed equally between each side.

#### WARNING

Have a fire extinguisher available when refueling!  
Smoking and naked flames during fueling is prohibited within  
10 m radius from the aircraft!  
Obey the local valid fire hazard legislation!

#### WARNING

Never fill up the fuel tanks with the engine running!  
**MASTER SWITCH** and **IGNITION** must be switched OFF!  
Nobody is allowed to be in the cockpit!

#### WARNING

Ground the aircraft before refueling!  
If a funnel is used, it must be conductively connected to the filler  
neck before refueling!

#### WARNING

Never use cloths, which produce static electricity for cleaning  
the area around the filler necks! Never clean the aircraft during  
refueling!

#### NOTE

The tanks in wings are connected to the fuselage tanks with  
a hose. The hose diameter is not sufficient for the fuel to flow  
immediately into the fuselage tank when refueling. Please wait  
until the fuel from the wing tank flows into the fuselage tank  
and then continue refueling.

#### NOTE

Keep the fuel tanks at least half full at all times to minimize  
condensation and moisture accumulation in tanks. In extremely  
humid areas, the fuel supply should be checked frequently and  
drained of condensation to prevent possible distribution problems.

### NOTE

For complete oil grades and specifications see OPERATORS MANUAL FOR ROTAX ENGINE TYPE 912 SERIES, Doc. No. OM-912 and Rotax Service Instructions SI-912-016, latest edition.

#### Filling of fuel tanks:

a.	<b>MASTER SWITCH</b>	Check OFF
b.	<b>IGNITION</b>	Check OFF both circuits
c.	Brake	Check <b>PARK</b>
d.	Fire extinguisher	Place near fuel tank being filled
e.	Ground wires	Attach to the exhaust tube
f.	Fuel tank cap	OPEN
g.	Fueling	Pour the suitable fuel type to desired level considering weight and CG limits
h.	Fuel tank cap	CLOSE and make sure that opening arm directs rearward
i.	Spilled fuel	Make sure that no spilled fuel is on the plane; clean if necessary
j.	Ground wires	Remove
k.	Fire extinguisher	Remove

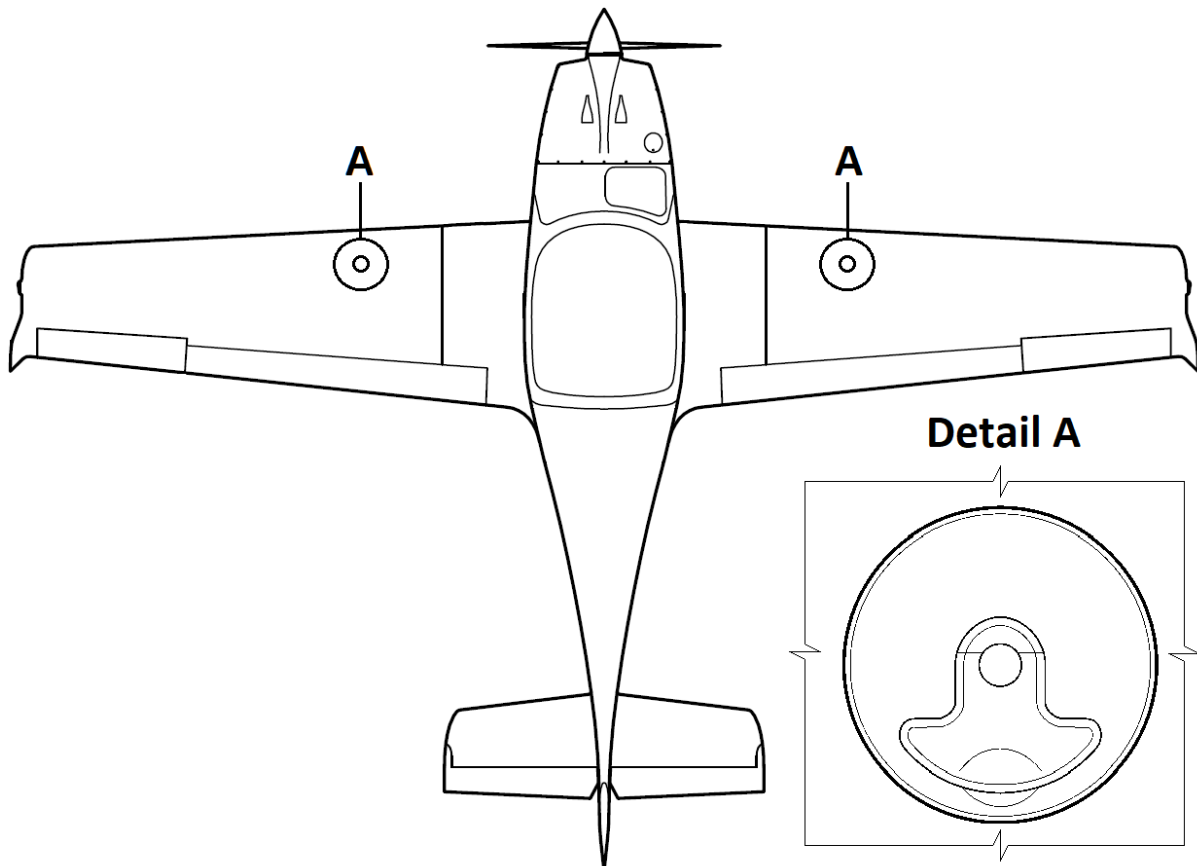

Fig. 8-4 Fuel servicing

### 8.3.2 Fuel Contamination and Sampling

Each fuel system drain must be sampled by draining into a clear sample cup. If sampling reveals contamination, sample again repeatedly until all contamination is removed. If evidence of significant contamination remains, do not fly until a mechanic is consulted. The fuel system must be drained and purged and the source of contamination determined. If improper fuel grade has been used, do not fly until the fuel system is drained and refueled with an approved fuel grade.

The fuel drain valves are located in the lowest point of each tank on wings and fuselage bottom surfaces (Fig. 8-5). Drain each fuel tank to remove accumulated water if any as follows:

**WARNING**  
**MASTER SWITCH** and **IGNITION** must be switched OFF!  
 Nobody is allowed to be in the cockpit!

**WARNING**  
 Smoking and naked flames during fuel draining is prohibited!

**WARNING**  
 Do not use materials which can cause static electricity during fuel draining!

**Fuel sampling:**

a.	<b>MASTER SWITCH</b>	Check OFF
b.	<b>IGNITION</b>	Check OFF both circuits
c.	Brake	Check <b>PARK</b>
d.	Fuel tank cap	OPEN
e.	Suitable bottle	Place below the drain valve
f.	Drain valve	Push and drain a small quantity of fuel and check
g.	Drain valve	CLOSE and check
h.	Fuel tank cap	CLOSE and make sure that opening arm directs rearward

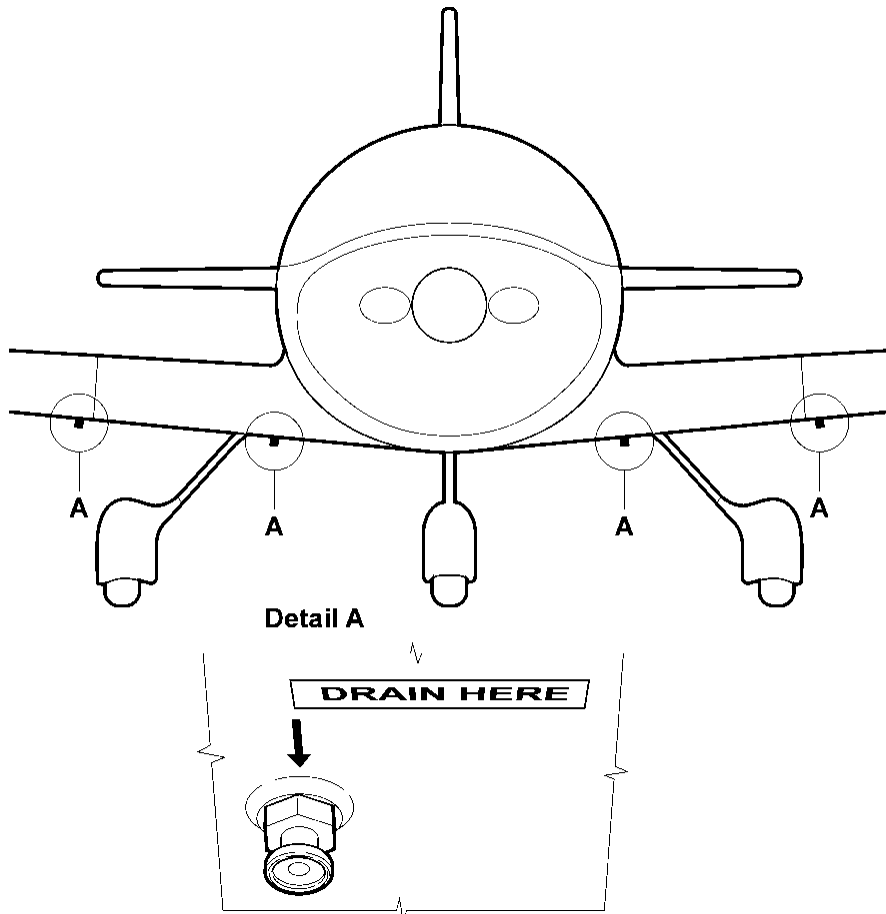

Fig. 8-5 Fuel draining

### 8.3.3 Oil Servicing

The oil tank is located in the engine compartment (Fig. 7-14). The capacity of oil system is 3.0-3.5 l / 0.79-0.92 U. S. gal. Maintain required oil level in the oil tank according to the dipstick. Fill up only with suitable oil according to specification in Chapter 2.9.2. Used oil is stated on the placard in the engine compartment.

When operating primarily on unleaded fuels or MOGAS, the maintenance intervals remain unchanged in regard to the maintenance schedule according to the Maintenance Manual for Rotax engine type 912 Series or Rotax Service Instructions SI-912-016, latest edition.

In the case of severe operating conditions (operation in cold/hot weather areas, interference by and/or salt), the time between maintenance intervals must generally be shorter, and in particular, the frequency of oil changes must be increased regardless of the type of fuel mainly used (MOGAS or AVGAS).

When operating with leaded AVGAS fuels, perform maintenance checks according to the latest Maintenance Manual for Rotax engine type 912 Series. More frequent oil changes will assure timely removal of residues and oil sludge thus avoiding increased wear or operating troubles.

Motor oils tested and released by BRP-Rotax (for use with unleaded fuel or MOGAS and leaded AVGAS) which engine manufacturer recommends for use with their Rotax Engine Type 912 Series are in the table below.

**WARNING**  
**MASTER SWITCH and IGNITION must be switched OFF!**  
Nobody is allowed to be in the cockpit!

**WARNING**  
Never crank the propeller when the engine is hot! Never service the oil if the engine is hot! Wait until the engine cools down to ambient temperature!

**CAUTION**  
Use only suitable oil according to the specification stated at placard in the engine compartment!

**NOTE**  
For complete oil grades and specifications see OPERATORS MANUAL FOR ROTAX ENGINE TYPE 912 SERIES, Doc. No. OM-912 and Rotax Service Instructions SI-912-016, latest edition.

### Oil check and replenishing:

a.	<b>MASTER SWITCH</b>	Check OFF
b.	<b>IGNITION</b>	Check OFF both circuits
c.	Brake	Check <b>PARK</b>
d.	Oil cowl door	OPEN
e.	Oil tank cap	OPEN
f.	Propeller	Crank (in direction of the engine rotation) by hand several times until a noticeable gurgle is heard, check for odd noises or excessive resistance and normal compression
g.	Oil quantity	Check the level with a dipstick and replenish as required
h.	Oil tank cap	CLOSE
i.	Oil cowl door	CLOSE

**8.3.4 Coolant Servicing**

The expansion tank is located in the engine compartment on the top of engine (Fig. 7-14). An overflow bottle is attached to the firewall (Fig. 7-14). Keep coolant level between the min. and max. level marks. Fill up only with suitable coolant according to specification in Chapter 2.9.3. Used coolant is stated on the placard in the engine compartment.

**WARNING**  
**MASTER SWITCH** and **IGNITION** must be switched OFF!  
 Nobody is allowed to be in the cockpit!

**WARNING**  
 Do not replenish the coolant if the engine is hot! Always let the engine cool down to ambient temperature!

**CAUTION**  
 Use only suitable coolant according to the specification stated on placard in the engine compartment! Never mix different types of coolants!

**NOTE**  
 For complete coolant specifications see OPERATORS MANUAL FOR ROTAX ENGINE TYPE 912 SERIES, Doc. No. OM-912 and Rotax Service Instructions SI-912-016, latest edition.

**Coolant replenishing:**

a. <b>MASTER SWITCH</b>	Check OFF
b. <b>IGNITION</b>	Check OFF both circuits
c. Brake	Check <b>PARK</b>
d. Upper engine cowling	Remove
e. Engine temperature	Check that the engine is cooled down to ambient temperature to avoid injury from hot coolant
f. Expansion tank	OPEN the expansion tank cap; add coolant if necessary and CLOSE the expansion tank cap
g. Overflow bottle	OPEN the overflow bottle cap; add coolant if necessary and CLOSE the overflow bottle cap
h. Upper engine cowling	Install

**8.3.5 Brake Fluid Servicing**

Brake fluid of D.O.T.4. should be used for the brake system. The brake fluid level should be checked at the annual or 100-hour inspection. For brake fluid check refer to the aircraft maintenance manual. Used brake fluid that is stated on the placard in the engine compartment.

### 8.4 Tire Inflating

Keep the tires inflated to the proper pressure. The nose wheel tire pressure is 200 kPa and the main gear tire pressure is 250 kPa. When checking the tire pressure, also examine the tires for wear, cuts and nicks.

All wheels and tires are balanced before original installation. In the case of new tire installation, it is necessary to rebalance the wheels with the tires fitted. Unbalanced wheels can cause vibration in the landing gear.

**WARNING**

**MASTER SWITCH and IGNITION must be switched OFF!**

Nobody is allowed to be in the cockpit!

**Tire inflating:**

a.	Brake	<b>PARK</b>
b.	<b>IGNITION</b>	Check OFF both circuits
c.	Wheel fairings	Remove the access hole's sticker to gain access to the tire valves of main wheels
d.	Brake	Release
e.	Aircraft	Move to gain access to the tire valves through the access hole in the wheel fairings
f.	<b>BRAKE</b>	<b>PARK</b>
g.	Nose wheel tire	Remove the tire valve cap, check/inflate 200 kPa and install the cap
h.	Main wheel tires	Remove the tire valve caps, check/inflate 250 kPa and install the caps
i.	Wheel fairings	Install the access hole's stickers



## 8.5 Cleaning and Care

Regular cleaning and care of the aircraft is the first consideration for safe and efficient operation. Cleaning and care should be based on climatic and flying conditions.

Before cleaning the aircraft cover the pitot probe ports.

Do not use abrasive cleaners or detergents that can make scratches on the paint or corrode the metal. Do not use a pressure washer to clean the aircraft or engine compartment to avoid damage.

### CAUTION

A dirty aircraft downgrades the flight performance!

### CAUTION

Before cleaning the aircraft cover the pitot probe ports!

### CAUTION

Do not use a pressure washer to clean the aircraft!

#### Cleaning windshield and windows:

Rinse away all dirt particles from windshield and windows before applying cloth or chamois. The windshield and windows should be cleaned with an aircraft windshield cleaner or water mixed with detergent. Apply the cleaner sparingly with a soft cloth or chamois and rub with moderate pressure until all dirt, oil scum and bug stains are removed. Never rub a dry windshield or windows. Finally wipe the cleaner off with soft flannel cloths.

### CAUTION

Do not clean the windshield and windows with alcohol, acetone or lacquer thinner, because they are made from acrylic. Acrylic becomes fragile after contact with these liquids!

### CAUTION

Never rub a dry windshield or windows!

#### Exterior cleaning:

Flush away loose dirt with water first. The exterior surfaces should be cleaned with a mild soap and water using a sponge or soft cotton towel and chamois. These surfaces may be finally protected using good commercial wax reapplied at least once a year by hand or with a rotating cloth disc. A thin coat of polished wax will fill minor scratches and help prevent further scratching.

#### Interior cleaning:

The interior painted surfaces should be cleaned with water mixed with detergent using a sponge or soft cotton towel. Seats, carpet and upholstery panels should be vacuumed to remove surface dirt and dust. While vacuuming, use a fine bristle nylon brush to help loosen particles.

### Engine compartment cleaning:

When cleaning the engine, the dissolved residues of fuel, oil and other environment contaminating agents are rinsed off. Collect the cleaning water and dispose of it in accordance with applicable environmental regulations. Do not use easily inflammable liquids or caustic cleaning agents for cleaning the engine. Take care to avoid solvents or water from entering electric parts of the engine installation.

a.	<b>MASTER SWITCH</b>	Check OFF
b.	<b>IGNITION</b>	Check OFF both circuits
c.	Brake	Check <b>PARK</b>
d.	Upper engine cowling	Remove
e.	Engine temperature	Check if the engine is cooled down to ambient temperature
f.	Engine compartment	Clean as required
g.	Upper engine cowling	Install

### WARNING

**MASTER SWITCH** and **IGNITION** must be switched OFF!  
Nobody is allowed to be in the cockpit!

### CAUTION

Do not clean the engine if it is hot! Always let the engine cool down to ambient temperature!

### CAUTION

Do not spray solvents into the alternator, starter or induction air intakes! Do not operate the engine until excess solvent has evaporated or otherwise been removed!

### NOTE

For more details refer to MAINTENANCE MANUAL FOR ROTAX ENGINE TYPE 912 SERIES, Doc. No. MM-912, latest edition.

### Propeller cleaning:

Cleaning the propeller is performed using water mixed with soap or detergent applied with a sponge and finished with a chamois.

a.	<b>MASTER SWITCH</b>	Check OFF
b.	<b>IGNITION</b>	Check OFF both circuits
c.	Brake	Check <b>PARK</b>
d.	Propeller	Clean as required

### WARNING

**MASTER SWITCH** and **IGNITION** must be switched OFF!  
Nobody is allowed to be in the cockpit!

### NOTE

For more details refer to Aircraft Maintenance Manual  
AS-AMM-01-000, Chapter 61.

## 8.6 Winter Operation

### Pre-flight inspection:

During the pre-flight inspection in winter additional checks must be done:

- Remove the frost, ice, snow or other contamination from the aircraft surfaces
- Check the control surfaces and flaps for free movement, full deflections and cleanness of slots
- Check the cleanness of the fuel tank venting

### WARNING

During winter operations, snow can accumulate in the wheel fairings, which may result in increased aircraft weight and change of CG position!

### Engine preheating:

It is possible to start the engine without needing to preheat if the outside temperature is above +5 °C. It is recommended to preheat the engine and oil if the temperature falls below +5 °C.

Blow hot air into the nose wheel well from the underside (Fig. 8-6). Temperature of the hot air should not exceed 50 °C. Preheat until coolant and oil temperature exceed +20 °C.

Use a suitable air heater and read the heater manual first. Obey local valid fire hazard legislation.

### WARNING

Never use open fire to preheat the engine!  
Obey the local valid fire hazard legislation!  
Never leave the aircraft unattended while pre-heating!

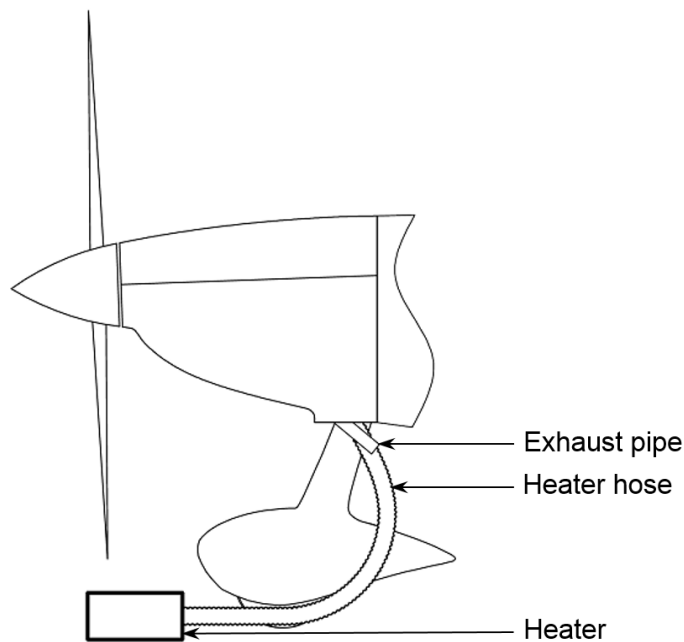

Fig. 8-6 Engine preheating

### Parking and taxiing:

Check wheel brakes for freezing when parking outside and the temperature is below 0 °C. Check the wheels are not obstructed (push/pull the aircraft by hand to ensure free rotation of the wheels) prior to taxiing. Heat the brakes with the hot air to remove ice. Do not try to remove the ice by braking during taxiing!

### CAUTION

Do not try to remove the ice by braking during taxiing!

### Coolant:

The water cooling system is originally filled with a coolant mixture protecting the cooling system against freezing up to temperature -38 °C. Check the condition of coolant mixture before winter operation to prevent the failure of the radiator or cooling system due to ice.

If the outside temperature is below coolant mixture freezing point, the coolant mixture must be drained or renewed using a pure coolant to gain a lower freezing point. If the entire system must be refilled, refer to the aircraft maintenance manual. Use only coolant according to the specification stated on the placard in the engine compartment.

### WARNING

Do not replenish the coolant if the engine is hot! Always let the engine cool down to ambient temperature!

### CAUTION

Use only suitable coolant according to the specification stated on the placard in the engine compartment! Never mix different types of coolants!

### NOTE

For complete coolant specifications see OPERATORS MANUAL FOR ROTAX ENGINE TYPE 912 SERIES, Doc. No. OM-912 and Rotax Service Instructions SI-912-016, latest edition.



## WT9 Dynamic LSA / Club

Pilot's Operating Handbook

AS-POH-01-000

---

This page is left blank intentionally

# 9 SUPPLEMENTS

## TABLE OF CONTENTS

9.1	INTRODUCTION .....	9-2
9.2	LIST OF INSERTED SUPPLEMENTS .....	9-3
9.3	MANUAL IMPROVEMENT REQUEST FORM .....	9-4
9.4	SAFETY OF FLIGHT AND SERVICE DIFFICULTY REPORT FORM.....	9-5
9.5	CHANGE OF AIRCRAFT OWNER ADDRESS NOTIFICATION FORM.....	9-6

### 9.1 Introduction

This chapter contains all supplements available for WT9 Dynamic LSA / Club necessary to safely and efficiently operate the aircraft when equipped with various optional systems and equipment not provided with the standard aircraft.

#### **NOTE**

Additional individual equipment in accordance with a customer's request may increase the aircraft empty weight and reduce the allowed useful load!

If there are any suggestions for improvements to the content of the manual, please use the form in the Chapter 9.3.

If there are any safety of flight difficulty is observed, please use the form in the Chapter 9.4.

For the change of aircraft owner address notification, please use the form in the Chapter 9.5.

The forms can be delivered to the aircraft manufacturer by means of a post or via email. Contact data are stated at the top of the forms.



### 9.2 List of Inserted Supplements

EASA approved POH supplements must be in the aircraft for flight operations when specified optional equipment is installed or special operations are to be performed. A check mark (☑) in the column “Installed” Indicates that the corresponding supplement is installed in this POH.

Installed	Supplement No.	Title	Date	Revision
<input type="checkbox"/>	AS-POH-01-001	Equipment List 1	28. 04. 2021	Revision 5
<input type="checkbox"/>	AS-POH-01-003	Propeller KW-31 / Towing Operation	24. 11. 2020	Revision 3
<input type="checkbox"/>	AS-POH-01-004	Garmin GNC 255A NAV/COMM	15. 05. 2017	Initial issue
<input type="checkbox"/>	AS-POH-01-005	Garmin GTX 328 XPDR	15. 05. 2017	Initial issue
<input type="checkbox"/>	AS-POH-01-006	PM3000 Intercom	15. 05. 2017	Initial issue
<input type="checkbox"/>	AS-POH-01-009	KANNAD 406 AF-COMPACT ELT	15. 05. 2017	Initial issue
<input type="checkbox"/>	AS-POH-01-010	Garmin GTX 335 XPDR	12. 06. 2020	Initial issue
<input type="checkbox"/>	AS-POH-01-011	KANNAD AF INTEGRA ELT	29. 01. 2020	Initial issue
<input type="checkbox"/>	AS-POH-01-012	Simple Throttle Controller	24. 11. 2020	Initial issue

**9.3 Manual Improvement Request Form**

Aerospool spol. s r. o. Letisková 10 973 01 Prievidza Slovak republic <a href="mailto:airworthiness@aerospool.sk">airworthiness@aerospool.sk</a> <a href="http://www.aerospool.sk">www.aerospool.sk</a>	<p><b>MANUAL IMPROVEMENT REQUEST</b></p>	Aerospool reference No.:  Date:
--	--	---------------------------------------

Dear owner / operator / maintainer:  
 In the case of suggestions for improvement to the content of the manual, or if errors or omissions were found, please submit the proposed changes by means of MANUAL IMPROVEMENT REQUEST form. Fill the form and sent it to the above stated address via post or email.

Your contact information:

Name:	Telephone:	Email:
-------	------------	--------

Manual information:

Document number:	Revision:	Document name:
------------------	-----------	----------------

Data location in the manual (chapter number, page number, figure, table):

Description of change request (attach more sheets if necessary):

Reason of change request:

**9.4 Safety of Flight and Service Difficulty Report Form**

Aerospool spol. s r. o. Letisková 10 973 01 Prievidza Slovak republic <a href="mailto:airworthiness@aerospool.sk">airworthiness@aerospool.sk</a> <a href="http://www.aerospool.sk">www.aerospool.sk</a>	<p><b>SAFETY OF FLIGHT AND SERVICE DIFFICULTY REPORT</b></p>	Aerospool reference No.:
		Date:

Dear owner / operator / maintainer:  
 For continued increasing reliability of aircraft, we would like to ask you for your assistance in the case of safety of flight or service difficulty. Fill the feedback form and sent it to the above stated address via post or email.

Type of report:

SAFETY OF FLIGHT ISSUE       SERVICE DIFFICULTY

Name:

Contact information (telephone, email, address):

Date of detection:

Aircraft type / model:

S/N:

Engine:

S/N:

Propeller:

S/N:

Flight hours:

Engine operation hours:

**Safety of flight / service difficulty description (attach more sheets if necessary):**

### 9.5 Change of Aircraft Owner Address Notification Form

Aerospool spol. s r. o. Letisková 10 973 01 Prievidza Slovak republic <a href="mailto:airworthiness@aerospool.sk">airworthiness@aerospool.sk</a> <a href="http://www.aerospool.sk">www.aerospool.sk</a>	<h2 style="margin: 0;">CHANGE OF AIRCRAFT OWNER ADDRESS NOTIFICATION</h2>	Aerospool reference No.:  Date:
--	---	---------------------------------------

Dear owner:  
 Fill the change of address notification form and sent it to the above stated address via post or email.

Name of registered owner:	Aircraft registration number:
	Aircraft type:
	Aircraft model:
	Serial number:

Mailing address (if PO Box, include physical address):

City:	Zip code:
State:	Email:
Date:	Signature: